

GOVERNMENT OF THE DEMOCRATIC REPUBLIC OF THE SUDAN  
MINISTRY OF FINANCE AND ECONOMIC PLANNING  
PROJECT PREPARATION UNIT

WOSSAC: 6199  
631  
(624)

# COTTON MARKETING PROJECT

## Feasibility Study

### Annex 1 Inventory

SIR M MACDONALD & PARTNERS LIMITED

in association with

ASSOCIATED CONSULTANTS & PARTNERS

THE BRITISH COTTON GROWING ASSOCIATION LIMITED

HUNTING TECHNICAL SERVICES LIMITED

MOTT, HAY & ANDERSON INTERNATIONAL LIMITED

PEAT, MARWICK, MITCHELL, & COMPANY

FEBRUARY 1984

GOVERNMENT OF THE DEMOCRATIC REPUBLIC OF THE SUDAN  
MINISTRY OF FINANCE AND ECONOMIC PLANNING  
PROJECT PREPARATION UNIT

Red

553B SUDAN

6199

# COTTON MARKETING PROJECT

## Feasibility Study

COTTON MARKETING PROJECT

FEASIBILITY STUDY

## Annex 1 Inventory

The Final Report comprises the following four volumes:

1. Main Report
2. Annex 1 - Inventory
3. Annex 2 - Pest Control  
Annex 3 - Ginning  
Annex 4 - Transport and Storage
4. Annex 5 - Grading and Testing  
Annex 6 - Telecommunications  
Annex 7 - Marketing, Organisation and Management  
Annex 8 - Financial and Economic Analysis

SIR M MACDONALD & PARTNERS LIMITED

in association with

ASSOCIATED CONSULTANTS & PARTNERS

THE BRITISH COTTON GROWING ASSOCIATION LIMITED

HUNTING TECHNICAL SERVICES LIMITED

MOTT, HAY & ANDERSON INTERNATIONAL LIMITED

PEAT, MARWICK, MITCHELL & COMPANY

FEBRUARY 1984

## COTTON MARKETING PROJECT

### FEASIBILITY STUDY

The Final Report comprises the following four volumes:

1. Main Report
2. Annex 1 - Inventory
3. Annex 2 - Pest Control
- Annex 3 - Ginning
- Annex 4 - Transport and Storage
4. Annex 5 - Grading and Testing
- Annex 6 - Telecommunications
- Annex 7 - Marketing, Organisation and Management
- Annex 8 - Financial and Economic Analysis

# ANNEX 1

## CONTENTS

### LIST OF TABLES

Table Nr		Title	
1.1	Ginnery Inventory	Buildings	Marangan
1.2	Ginnery Inventory	Infrastructure	Marangan
1.3.1	Ginnery Inventory	Machinery	Marangan Nr Factory 1
1.3.2	Ginnery Inventory	Machinery	Marangan Nr Factory 2
1.3.3	Ginnery Inventory	Machinery	Marangan Nr Factory 3

### PREFACE

This annex contains detailed inventories for each ginnery and for the stores at Port Sudan, together with tables of climatic data for the various ginnery locations.

The information for each ginnery comprises the following :

2.2	Ginnery Inventory	Infrastructure	Hushaisa
2.3.1	Ginnery Inventory	Machinery	Hushaisa Factory Nr 5
2.3.2	Ginnery Inventory	Machinery	Hushaisa Factory Nr 6
2.3.3	Ginnery Inventory	Machinery	Hushaisa Factory Nr 7
2.3.4	Ginnery Inventory	Machinery	Hushaisa Factory Nr 8
2.3.5	Ginnery Inventory	Machinery	Hushaisa Factory Nr 10
2.3.6	Ginnery Inventory	Machinery	Hushaisa Factory Nr 12
2.3.7	Ginnery Inventory	Machinery	Hushaisa Factory Nr 13
2.4	Ginnery Inventory	Power Supply	Hushaisa

Tables : Buildings  
Infrastructure  
Machinery (by factory)  
Power supply (where applicable)

Figures : General layout  
Electrical layout

All the Figures have been grouped together at the back of the volume.

3.3	Ginnery Inventory	Machinery	Baqat
3.4	Ginnery Inventory	Power Supply	Baqat
4.1	Ginnery Inventory	Buildings	Sennar
4.2	Ginnery Inventory	Infrastructure	Sennar
4.3	Ginnery Inventory	Machinery	Sennar
4.4	Ginnery Inventory	Power Supply	Sennar
5.1	Ginnery Inventory	Buildings	Hamadallah
5.2	Ginnery Inventory	Infrastructure	Hamadallah
5.3	Ginnery Inventory	Machinery	Hamadallah
5.4	Ginnery Inventory	Power Supply	Hamadallah
6.1	Ginnery Inventory	Buildings	Kassab
6.2	Ginnery Inventory	Infrastructure	Kassab
6.3.1	Ginnery Inventory	Machinery	Kassab Factory Nr 1
6.3.2	Ginnery Inventory	Machinery	Kassab Factory Nr 2
6.3.3	Ginnery Inventory	Machinery	Kassab Factory Nr 3
6.4	Ginnery Inventory	Power Supply	Kassab
7.1	Ginnery Inventory	Buildings	Duaim
7.2	Ginnery Inventory	Infrastructure	Duaim
7.3	Ginnery Inventory	Machinery	Duaim
7.4	Ginnery Inventory	Power Supply	Duaim

## ANNEX 1

## CONTENTS

## LIST OF TABLES

Table Nr	Title	
1.1	Ginnery Inventory	Buildings - Marangan
1.2	Ginnery Inventory	Infrastructure - Marangan
1.3.1	Ginnery Inventory	Machinery - Marangan Nr Factory 1
1.3.2	Ginnery Inventory	Machinery - Marangan Nr Factory 2
1.3.3	Ginnery Inventory	Machinery - Marangan Nr Factory 3
1.3.4	Ginnery Inventory	Machinery - Marangan Nr Factory 4
1.3.5	Ginnery Inventory	Machinery - Marangan Nr Factory 11
1.4	Ginnery Inventory	Power Supply - Marangan
2.1	Ginnery Inventory	Buildings - Hasaheisa
2.2	Ginnery Inventory	Infrastructure - Hasaheisa
2.3.1	Ginnery Inventory	Machinery - Hasaheisa Factory Nr 5
2.3.2	Ginnery Inventory	Machinery - Hasaheisa Factory Nr 6
2.3.3	Ginnery Inventory	Machinery - Hasaheisa Factory Nr 7
2.3.4	Ginnery Inventory	Machinery - Hasaheisa Factory Nr 8
2.3.5	Ginnery Inventory	Machinery - Hasaheisa Factory Nr 10
2.3.6	Ginnery Inventory	Machinery - Hasaheisa Factory Nr 12
2.3.7	Ginnery Inventory	Machinery - Hasaheisa Factory Nr 13
2.4	Ginnery Inventory	Power Supply - Hasaheisa
3.1	Ginnery Inventory	Buildings - Bageir
3.2	Ginnery Inventory	Infrastructure - Bageir
3.3	Ginnery Inventory	Machinery - Bageir
3.4	Ginnery Inventory	Power Supply - Bageir
4.1	Ginnery Inventory	Buildings - Sennar
4.2	Ginnery Inventory	Infrastructure - Sennar
4.3	Ginnery Inventory	Machinery - Sennar
4.4	Ginnery Inventory	Power Supply - Sennar
5.1	Ginnery Inventory	Buildings - Hamadnallah
5.2	Ginnery Inventory	Infrastructure - Hamadnallah
5.3	Ginnery Inventory	Machinery - Hamadnallah
5.4	Ginnery Inventory	Power Supply - Hamadnallah
6.1	Ginnery Inventory	Buildings - Kassab
6.2	Ginnery Inventory	Infrastructure - Kassab
6.3.1	Ginnery Inventory	Machinery - Kassab Factory Nr 1
6.3.2	Ginnery Inventory	Machinery - Kassab Factory Nr 2
6.3.3	Ginnery Inventory	Machinery - Kassab Factory Nr 3
6.4	Ginnery Inventory	Power Supply - Kassab
7.1	Ginnery Inventory	Buildings - Dueim
7.2	Ginnery Inventory	Infrastructure - Dueim
7.3	Ginnery Inventory	Machinery - Dueim
7.4	Ginnery Inventory	Power Supply - Dueim

## LIST OF TABLES (cont.)

Table Nr	Title		
8.1	Ginnery Inventory	Buildings	- Kosti
8.2	Ginnery Inventory	Infrastructure	- Kosti
8.3	Ginnery Inventory	Machinery	- Kosti
8.4	Ginnery Inventory	Power Supply	- Kosti
9.1	Ginnery Inventory	Buildings	- Rabak
9.2	Ginnery Inventory	Infrastructure	- Rabak
9.3	Ginnery Inventory	Machinery	- Rabak
9.4	Ginnery Inventory	Power Supply	- Rabak
10.1	Ginnery Inventory	Buildings	- Fau
10.2	Ginnery Inventory	Infrastructure	- Fau
10.3.1	Ginnery Inventory	Machinery	- Fau Factory Nr 1
10.3.2	Ginnery Inventory	Machinery	- Fau Factory Nr 2
10.3.3	Ginnery Inventory	Machinery	- Fau Factory Nr 3
10.3.4	Ginnery Inventory	Machinery	- Fau Factory Nr 4
10.4	Ginnery Inventory	Power Supply	- Fau
11.1	Ginnery Inventory	Buildings	- New Halfa
11.2	Ginnery Inventory	Infrastructure	- New Halfa
11.3.1	Ginnery Inventory	Machinery	- New Halfa Factory Nr 1
11.3.2	Ginnery Inventory	Machinery	- New Halfa Factory Nr 2
11.3.3	Ginnery Inventory	Machinery	- New Halfa Factory Nr 3
11.4	Ginnery Inventory	Power Supply	- New Halfa
12.1	Ginnery Inventory	Buildings	- Zeidab
12.2	Ginnery Inventory	Infrastructure	- Zeidab
12.3	Ginnery Inventory	Machinery	- Zeidab
12.4	Ginnery Inventory	Power Supply	- Zeidab
13.1	Ginnery Inventory	Buildings	- Port Sudan
13.2	Ginnery Inventory	Infrastructure	- Port Sudan
13.3	Ginnery Inventory	Machinery	- Port Sudan
13.4	Ginnery Inventory	Power Supply	- Port Sudan
14.1	Ginnery Inventory	Buildings	- Kadugli
14.2	Ginnery Inventory	Infrastructure	- Kadugli
14.3	Ginnery Inventory	Machinery	- Kadugli
15.1	Ginnery Inventory	Buildings	- Talodi
15.2	Ginnery Inventory	Infrastructure	- Talodi
15.3	Ginnery Inventory	Machinery	- Talodi
16.1	Ginnery Inventory	Buildings	- Kologi
16.2	Ginnery Inventory	Infrastructure	- Kologi
16.3	Ginnery Inventory	Machinery	- Kologi
17.1	Ginnery Inventory	Buildings	- Abu Gebeiha
17.2	Ginnery Inventory	Infrastructure	- Abu Gebeiha
17.3	Ginnery Inventory	Machinery	- Abu Gebeiha

## LIST OF TABLES (cont.)

Table Nr	Title		
18.1	Ginnery Inventory	Buildings	- Umm Berembeita
18.2	Ginnery Inventory	Infrastructure	- Umm Berembeita
18.3	Ginnery Inventory	Machinery	- Umm Berembeita
19.1	Ginnery Inventory	Buildings	- Semeih
19.2	Ginnery Inventory	Infrastructure	- Semeih
19.3	Ginnery Inventory	Machinery	- Semeih
20.1	Ginnery Inventory	Buildings	- Dilling
20.2	Ginnery Inventory	Infrastructure	- Dilling
20.3	Ginnery Inventory	Machinery	- Dilling
21.1	Ginnery Inventory	Buildings	- Lagowa
21.2	Ginnery Inventory	Infrastructure	- Lagowa
21.3	Ginnery Inventory	Machinery	- Lagowa
22.1	Ginnery Inventory	Buildings	- Damazin
22.2	Ginnery Inventory	Infrastructure	- Damazin
22.3	Ginnery Inventory	Machinery	- Damazin
22.4	Ginnery Inventory	Power Supply	- Damazin
23.1	Port Sudan Stores Inventory	-	Central Area
23.2	Port Sudan Stores Inventory	-	Northern Area
23.3	Port Sudan Stores Inventory	-	Hadali Area
24.1	Characteristic Climatic Parameters : Marangan and Hasaheisa		
24.2	Characteristic Climatic Parameters : Bageir		
24.3	Characteristic Climatic Parameters : Sennar and Hamadnallah		
24.4	Characteristic Climatic Parameters : Dueim		
24.5	Characteristic Climatic Parameters : Kostî and Rabak		
24.6	Characteristic Climatic Parameters : Fau		
24.7	Characteristic Climatic Parameters : New Halfa		
24.8	Characteristic Climatic Parameters : Zeidab		
24.9	Characteristic Climatic Parameters : Port Sudan		
24.10	Characteristic Climatic Parameters : Damazin		
24.11	Characteristic Climatic Parameters : Nuba Mountains		

## LIST OF FIGURES

Figure Nr	Title
1	Marangan Ginnery General Layout
2	Hasaheisa Ginnery General Layout
3	Bageir Ginnery General Layout
4	Sennar Ginnery General Layout
5	Hamadnallah Ginnery General Layout
6	Kassab Ginnery General Layout
7	Dueim Ginnery General Layout
8	Kosti Ginnery General Layout
9	Rabak Ginnery General Layout
10	Fau Ginnery General Layout
11	New Halfa Ginnery General Layout
12	Zeidab Ginnery General Layout
13	Port Sudan Ginnery General Layout
14	Kadugli Ginnery General Layout
15	Talodi Ginnery General Layout
16	Kologi Ginnery General Layout
17	Abu Gebeiha Ginnery General Layout
18	Umm Berembeita Ginnery General Layout
19	Semeih Ginnery General Layout
20	Dilling Ginnery General Layout
21	Lagowa Ginnery General Layout
22	Damazin Ginnery General Layout
23	Marangan Ginnery Electrical layout
24	Hasaheisa Ginnery Electrical Layout
25	Bageir Ginnery Electrical Layout
26	Sennar Ginnery Electrical Layout
27	Hamadnallah Ginnery Electrical Layout
28	Kassab Ginnery Electrical Layout
29	Dueim Ginnery Electrical Layout
30	Kosti Ginnery Electrical Layout
31	Rabak Ginnery Electrical Layout
32	Fau Ginnery Electrical Layout
33	New Halfa Ginnery Electrical Layout
34	Zeidab Ginnery Electrical Layout
35	Damazin Ginnery Electrical Layout

TABLE 1.1

GINNERY INVENTORY: BUILDINGS

Building	Description	Approximate dimensions L x W x H (m)	Comments
Main Buildings Ginning factories Nr 1, 2, 3, 4	Structure : framed steel stanchions and trusses	120 x 30 x 7	All in good condition, no remedial works required. If factory Nr 4 is mechanised then the floor will need remodelling to accommodate lint chutes.
	Walls : GCI sheeting		
	Roof : GCI sheeting		
Ginning factory Nr 11	Floor : concrete jack arches above basement	130 x 30 x 7	In good condition, no remedial works required.
	Structure : concrete frame		
	Walls : brickwork infill		
Offices	Roof : concrete domes	30 x 15 x 2	In good condition, no remedial works required.
	Floor : concrete slabs		
	Structure : load bearing brick (2 storey)		
Stores 11 Nr in total	Roof : GCI sheeting	6 Nr 100 x 35 x 7 5 Nr 100 x 40 x 7	A new warehouse (100 x 40 x 7) is under construction which will bring total Nr to 12. All are in good condition and no remedial works are required. Stores are not only for ginnery use but are primarily used for storage of agricultural inputs, etc.
	Floor : concrete tiles		
	Structure : steel frame		
	Walls : blockwork and GCI sheeting		
Workshop	Roof : GCI sheeting	75 x 37 x 5	Good condition, no remedial work required.
	Floor : concrete		
	Structure : steel frame		
Other Buildings Fire office and station	Walls : GCI sheeting	various	All in reasonable condition, some maintenance required.
	Roof : GCI sheeting		
	Floor : concrete		
Latrine blocks Pump houses GLR offices and stores	Brickwork and GCI roofing		
Amenity buildings Small offices Workshop annexes			
Seed treatment room			
Stores for treated seed			

TABLE 1.2

## GINNERY INVENTORY: INFRASTRUCTURE

LOCATION: MARANGAN

Facility	Description	Comments						
Water Supply	Fire canal supplied from Barakat Minor. 3 Nr. 18 m high steel tanks (12 000 gallons) are fed by pumps from the fire canal.	No problems are reported.						
(a) Firefighting	2 tanks supply sprinkler systems in factories 1, 2, 3 and 4 and 1 tank supplies the stores sprinkler systems. 2 Nr. 60 m deep wells supply 18 m high tank (24 000 gallons) and sprinkler system for factory Nr. 11. 52 Nr. ground tanks (5 000 gallons) are provided for yard fire fighting.							
(b) Domestic and other uses	5 Nr. 60 m deep wells provide supply. Three are in residential area with 14 m high (16 000 gallons) tank. Two are in factory area with 15 m high (20 000 gallons) tank. Distribution by galvanised steel pipes.	It is reported that there is an inadequacy of supply and tanks are frequently not filled. Interconnecting 2 Nr. wells at factory Nr. 11 into the system may alleviate the problem.						
Surface Water Drainage	No special provisions are made. Natural drainage occurs to the north-east.	The area adjacent to factory Nr. 11 retains water after heavy rain and has to be drained by pumping water into fire canal.						
Sewage Disposal	Bucket latrines.							
Roads/Access	300 m gravel road connects office area to Barakat/Wad Medani road (asphalt). No other roads on factory site. Gezira Light Railway and Sudan Railways systems.							
Fencing	Barbed wire and steel angle posts.	In good condition.						
Platforms and Hardstandings	Concrete platforms approximately 30 x 15 m provided at both ends of each factory (total area 4 500 m <sup>2</sup> ). No other hard-standing.	In good condition.						
Houses	Adjacent to the factory site there are the following houses owned by SGB: <table border="1" data-bbox="1150 1324 1237 1626"> <tr> <td>Senior type</td> <td>29</td> </tr> <tr> <td>Middle type</td> <td>82</td> </tr> <tr> <td>Junior type</td> <td>725</td> </tr> </table> Construction is of brick, jack arch or GCI sheeting roofs, concrete tile floors. Sanitation is by aqua privy, bucket and pit latrine. Bucket and pit latrines are gradually being replaced by water-borne systems with septic tanks or aqua privies.	Senior type	29	Middle type	82	Junior type	725	Houses are maintained every three years and are in reasonable condition. The majority of houses are used by ginnery staff; reportedly 60% senior and middle houses and 80% of junior houses. Other houses are used by SGB agricultural and other employees. Other buildings in the residential area include dispensary, school, co-operative shop.
Senior type	29							
Middle type	82							
Junior type	725							

TABLE 1.3.1

LOCATION : MARANGAN FACTORY Nr 1

GINNERY INVENTORY: MACHINERY

System	Method	Make	Type	Year	Serial Nr	Power	Comment
<b>Power Supply</b>	Blue Nile Grid Transformers						
<b>Seed Cotton Conveying from Yard</b>	Manual loading/unloading contractors tractors/trailers - supplemented with S.G.B. field tractors	Massey-Ferguson					
<b>Conveyance within Ginnery</b>	Manual unloading and emptying of sacks onto outer floor areas behind gin stands.						Good condition, all operational
<b>s/c Cleaning</b>	Manual feeding into feeder hoppers	Platt	Lattice type		N/A		
<b>s/c Conditioning</b>	Nil machinery			1925	N/A	8 KW	Extremely old - difficulty in obtaining spares.
<b>Gin Stands</b>	Atmospheric humidifying, within gin hall. Roller - 92 No.	Mather & Platt Platt	Vortex Model 2 Single Acting Single Roller c/w Barakat double stripping rollers		N/A	343 KW	Good condition - well maintained 34 Kgs lint per gin hour Barakat 23 Kgs lint per gin hour on Acala
<b>Cotton Seed Seed Conveying</b>	Mechanical Bucket Elevators	Platts	Shaker conveyor 8 No. Transverse conveyors 2 No. 2 No.		N/A N/A N/A	30 KW 11 KW 15 KW	Good condition Ditto Ditto

Scarto	Seed Gribbles 2 No. Scarto lint recovery - saw gins	Rosedowns Platts	Rotary screen drum 4 x 40x 8" O.D. saw brush gins	N/A N/A	10 KW 15 KW	Good condition Difficulty with spares
<b>Cotton Lint</b> Lint Conveying	Manual loading/unloading into 2 No. trucks running along central aisle to each bale press.					
Lint Conditioning	Manual application		Measured amount of water sprayed via hose.			Poorly applied
Lint Baling	Hydraulic bale press - manual loading 2 No. (East & West wings)  Press Pump 2 No.	Hydraulic Eng.  Chester	Hydraulic (water) up-packing single cylinder press - foot tramper	N/A  N/A	  60 KW	Box size 25" x 39" Standard Density 185 kg.av. bale. 6 Bale straps

TABLE 1.3.2

LOCATION : MARANGAN FACTORY Nr 2

GINNERY INVENTORY : MACHINERY

System	Method	Make	Type	Year	Serial Nr	Power	Comment
Power Supply	Blue Nile Grid Transformers						
Seed Cotton Conveying from Yard	Manual loading/unloading contractors tractors/trailers - supplemented with S.G.B. field tractors	Massey-Ferguson					
Conveyance within Ginnery	Manual unloading and emptying of sacks onto outer floor areas behind gin stands.						
s/c Cleaning	Manual feeding into feeder hoppers	Platt	Lattice type		N/A		Good condition, all operational
s/c Conditioning	Nil machinery						
	Atmospheric humidifying, within gin hall.	Mather & Platt	Vortex	1925	N/A	8 KW	Extremely old - difficulty in obtaining spares.
Gin Stands	Roller - 92 No.	Platt	Model 2 Single Acting Single Roller c/w Barakat double stripping rollers		N/A	343 KW	Good condition - well maintained 34 Kgs lint per gin hour Barakat 23 Kgs lint per gin hour on Acala
Cotton Seed Seed Conveying	Mechanical	Platts	Shaker conveyer 8 No. Transverse conveyors 2 No.		N/A	30 KW	Good condition
	Bucket Elevators				N/A	11 KW	Ditto
					N/A	15 KW	Ditto

Scarto	Seed Gribbles 2 No. Scarto lint recovery - saw gins	Rosedowns Platts	Rotary screen drum 4 x 40x 8" O.D. saw brush gins	N/A N/A	10 KW 15 KW	Good condition Difficulty with spates
<b>Cotton Lint</b> Lint Conveying	Manual loading/unloading into 2 No. trucks running along central aisle to each bale press.					
<b>Lint Conditioning</b>	Manual application		Measured amount of water sprayed via hose.			Poorly applied
<b>Lint Baling</b>	Hydraulic bale press - manual loading 2 No. (East & West wings)  Press Pump 2 No.	Hydraulic Eng.  Chester	Hydraulic (water) up-packing single cylinder press - foot tramper	N/A  N/A	  60 KW	Box size 25" x 39" Standard Density 185 kg.av. bale. 6 Bale straps

TABLE 1.3.3

GINNERY INVENTORY : MACHINERY

LOCATION : MARANGAN FACTORY Nr 3

System	Method	Make	Type	Year	Serial Nr	Power	Comment
Power Supply	Blue Nile Grid Transformers						
Seed Cotton Conveying from Yard	Manual loading/unloading contractors tractors/trailers - supplemented with S.G.B. field tractors	Massey-Ferguson					
Conveyance within Ginnery	Manual unloading and emptying of sacks onto outer floor areas behind gin stands.						East wing has pneumatic system which dumps s/c behind gin stands.
s/c Cleaning	Manual feeding into feeder hoppers	Platt	Lattice type		N/A		Good condition, all operational
s/c Conditioning	Nil machinery						
	Atmospheric humidifying, within gin hall.	Mather & Platt	Vortex	1925	N/A	8 KW	Extremely old - difficulty in obtaining spares.
Gin Stands	Roller - 92 No.	Platt	Model 2 Single Acting Single Roller c/w Barakat double stripping rollers		N/A	343 KW	Good condition - well maintained 34 Kgs lint per gin hour Barakat 23 Kgs lint per gin hour on Acala
Cotton Seed Seed Conveying	Mechanical	Platts	Shaker conveyor 8 No. Transverse conveyors 2 No.		N/A	30 KW	Good condition
	Bucket Elevators				N/A	11 KW	Ditto
					N/A	15 KW	Ditto

**Scarto**

Seed Gribbles 2 No.  
Scarto lint recovery - saw gins

Rosedowns  
Platts

Rotary screen drum  
4 x 40x 8" O.D. saw  
brush gins

N/A  
N/A

10 KW  
15 KW

Good condition  
Difficulty with spares

**Cotton Lint**

Lint Conveying

Manual loading/unloading into 2 No. trucks running along central aisle to each bale press.

Lint Conditioning

Manual application

Measured amount of water sprayed via hose.

Poorly applied

Lint Baling

Hydraulic bale press - manual loading 2 No. (East & West wings)

Hydraulic Eng.

Hydraulic (oil) up-packing single cylinder press - foot tramper

N/A

1960

Box size 25" x 39"  
Standard Density 185 kg.av.  
bale.  
6 Bale straps

Press Pump 2 No.

Chester

N/A

60 KW

TABLE 1.3.4

GINNERY INVENTORY : MACHINERY

LOCATION : MARANGAN FACTORY Nr 4

System	Method	Make	Type	Year	Serial Nr	Power	Comment
Power Supply	Blue Nile Grid Transformers						
Seed Cotton Conveying from Yard	Manual loading/unloading contractors tractors/trailers - supplemented with S.G.B. field tractors	Massey-Ferguson					
Conveyance within Ginnery	Manual unloading and emptying of sacks onto outer floor areas behind gin stands.						
s/c Cleaning	Manual feeding into feeder hoppers	Platt	Lattice type		N/A		Good condition, all operational
s/c Conditioning	Nil machinery						
	Atmospheric humidifying, within gin hall.	Mather & Platt	Vortex	1925	N/A	8 KW	Extremely old - difficulty in obtaining spares.
Gin Stands	Roller - 92 No.	Platt	Model 2 Single Acting Single Roller c/w Barakat double stripping rollers		N/A	343 KW	Good condition - well maintained 34 Kgs lint per gin hour Barakat 23 Kgs lint per gin hour on Acala
Cotton Seed	Mechanical	Platts	Shaker conveyor 8 No.		N/A	30 KW	Good condition
Seed Conveying	Bucket Elevators		Transverse conveyors 2 No.		N/A	11 KW	Ditto
			2 No.		N/A	15 KW	Ditto

Scarto	Seed Gribbles 2 No. Scarto lint recovery - saw gins	Rosedowns Platts	Rotary screen drum 4 x 40x 8" O.D. saw brush gins	1969	N/A	10 KW 15 KW	Good condition Difficulty with spares
Colton Lint Lint Conveying	Manual loading/unloading into 2 No. trucks running along central aisle to each bale press.						
Lint Conditioning	Manual application		Measured amount of water sprayed via hose.				Poorly applied
Lint Baling	Hydraulic bale presses and mechanical tampers - 2 No. Press Pump 2 No.	Hardwick Etter Chester	Semi-Auto-hydraulic oil up-packing presses c/w rotating boxes	1977	N/A	Box size 25" x 39" Standard Density 185 kg.av. bale	

ГОСУДАРСТВЕННЫЙ НАУЧНО-ИССЛЕДОВАТЕЛЬСКИЙ ЦЕНТР ТЕКСТИЛЬНО-ПРОИЗВОДСТВЕННОГО КОМПЛЕКСА

TABLE 1.3.5

LOCATION : MARANGAN FACTORY Nr 11

GINNERY INVENTORY : MACHINERY

System	Method	Make	Type	Year	Serial Nr	Power	Comment
Power Supply	Blue Nile Grid Transformers						
Seed Cotton Conveying within Yard	Contractors tractors/trailers supplemented by SGB field tractors	Massey Ferguson					
Conveying within Ginnery	Pneumatic/mechanical, s/c fed into 4 No. mixing room suction pipes and delivered to separators and Conveyors	Davidson Platts "	Scitrocco suction fans 4 - No. Air Separators - 4 No. Separator feed controls 8 No.	1964	N/A N/A N/A	120 KW 22 KW 4 KW	Good condition Ditto
s/c Cleaning	Nil machinery	Platts	Screw conveyors 8 No. Overflow conveyors 4 No. Auto feeders 92 No.	" "	N/A N/A	30 KW 10 KW	Ditto
s/c Conditioning	Atmospheric humidification	Mellor Bromley	Multiple fan blower units located throughout factory. 56 No. Water pumps 6 No.	"	N/A	30 KW 18 KW	Fine dust only removed in pneumatic suction system Poor design layout results in continual drain blockages caused by lint fly. Rarely in use
Gin Stands	Roller - 92 No.	Platts	Model 2 Single Acting single roller c/w Barakat double stripper	1964	N/A	343 KW	Good condition and operation

<b>Cotton Seed</b>									
Seed Conveying	Underfloor conveyors Elevators	Platts	Shaker conveyors 12 No. Bucket 2 No.	1964	N/A	60 KW 20 KW	Good condition and operation Ditto		
<b>Scarto</b>	Rotary drum seed/s.c. separator	Rosedowns	2 section screen 2 No.	"	N/A	15 KW	4 Bagging points		
Lint Recovery	Saw Gins	Platts	40 x 8" OD saw brush gins - 4 No.	"	N/A	15 KW	Fair condition - spare parts problem.		
<b>Cotton Lint</b>									
Lint Conveying	Mechanical - below gin stands	"	Conveyor Belts	"	N/A	9 KW	Good condition and operation		
	Condensers - 2 No.	Platt Lummus	Revolving drum 40" x 50"	"	N/A	4 KW	Ditto		
	Lint pull fans	"	V.A. Fans - 2 No.	"	N/A	20 KW	Ditto		
	Lint feeders to bale press	"	Kicker paddle	"	N/A	8 KW	Ditto		
Lint conditioning	Lint slide spray	Kemgas	Statifier sprays	"	N/A	2 KW			
Lint Baling	Hydraulic Bale presses 2 No.	Platt Lummus	Hydraulic oil up packing semi auto bale press c/w mechanical tramper	1964	N/A Trampers Press Pumps	30 KW 60 KW	Good condition and operation		

TABLE 2.1

GINNERY INVENTORY: BUILDINGS

Building	Description	Approximate dimensions L x W x H (m)	Comments
<b>Main Buildings</b> Ginning factories Nrs 5, 6, 7, 8	Structure : steel framed stanchions and trusses Walls : GCI sheeting Roof : GCI sheeting Floor : concrete jack arches above basement	120 x 30 x 7	All in good condition, no remedial works required. If factories Nr 5 and 6 are mechanised then the floor will need remodelling to accommodate lint chute. Factory Nr 8 was damaged by fire after the inventory visit. It is understood that there was no significant damage to the building.
Ginning factory Nr 10 (including seed treatment room)	Structure : steel framed Walls : GCI sheeting Roof : GCI sheeting Floor : concrete	50 x 33 x 6.5	In good condition, no remedial works required
Ginning factory Nr 12	Structure : concrete frame Walls : brickwork infill Roof : concrete domes Floor : concrete	120 x 30 x 7	In good condition, no remedial works required.
Ginning factory Nr 13	As factory Nr 10	100 x 25 x 6.5	In good condition, no remedial works required.
Offices (2 Nr)	Structure : load bearing brickwork Roof : GCI sheeting Floor : concrete tiles	40 x 20 x 4 25 x 15 x 4	In good condition, no remedial works required.
Main stores 7 Nr	Structure : steel frame Walls : GCI sheeting Roof : GCI sheeting Floor : concrete	100 x 40 x 7	All in good condition, no remedial works required. Stores are not only for ginnery use but are primarily used for storage of agricultural inputs, etc.
Other stores 5 Nr	As for main stores	40 x 15 x 5 (3 Nr) 3 x 20 x 5 (1 Nr) 30 x 15 x 6 (1 Nr)	All in good condition, no remedial works required. Used for short term storage for ginnery and agricultural purposes.
Workshop	As for main stores	30 x 12 x 5	Newly constructed, in good condition.
<b>Other Buildings</b> Fire station Amenity buildings Latrine blocks Pump houses Small offices	Brick built	various	All in reasonable condition, some maintenance required.

TABLE 2.2

LOCATION: HASAHEISA

GINNERY INVENTORY: INFRASTRUCTURE

Facility	Description	Comments						
Water Supply (a) Firefighting	A ring fire canal is the main source. Four 18 m high (12 000 gallons) tanks are fed from the canal and provide water for the sprinkler systems in factories 5, 6, 7, 8, 10 and 13. Factory 12 sprinkler system is fed from 2 Nr 60 m deep wells via an 18 m high storage tank (24 000 gallons), 52 Nr (5 000 gallon) ground tanks are provided for yard fire fighting.	Firefighting system is adequate.						
(b) Domestic and other uses	3 Nr 60 m deep wells provide water for domestic and other uses via a 12 m high steel tank (16 000 gallons) to the factory and domestic areas. Distribution by galvanised steel pipes.	A shortage of domestic water is reported.						
Surface Water Drainage	No special provisions are made. Local drainage is achieved when necessary by digging sumps and pumping to fire canal.	No major problems reported.						
Sewage Disposal	Bucket latrines.							
Roads/Access	No surfaced roads within ginnery site. Gezira Light Railway and Sudan Railways system.	There is no surfaced road from main Khartoum/Wad Medani to ginnery, a distance of about 2 km. Access to site is therefore difficult following rains.						
Fencing	Barbed wire and steel angle posts.	In good condition.						
Platforms and Hardstandings	Concrete platforms approximately 30 x 15 m provided at both ends of each factories 5, 6, 7, 8 and 12 (total area 4 500 m <sup>2</sup> ). No other hard standing.	In good condition.						
Houses	Adjacent to the factory site there are the following houses owned by SGB : <table border="1" style="margin-left: 20px;"> <tr> <td>Senior type</td> <td>29</td> </tr> <tr> <td>Middle type</td> <td>82</td> </tr> <tr> <td>Junior type</td> <td>725</td> </tr> </table> <p>Construction is of brick, jack arch or GCI sheeting roofs, concrete tile floors. Sanitation is by aqua privy, bucket and pit latrine. Bucket and pit latrines are gradually being replaced by water borne systems with septic tanks or aqua privies.</p>	Senior type	29	Middle type	82	Junior type	725	Houses are maintained every three years and are in reasonable condition. The majority of houses are used by ginnery staff; reportedly 60% senior and middle houses and 80% of junior houses. Other houses are used by SGB agricultural and other employees. Other buildings in the residential area include dispensary and schools.
Senior type	29							
Middle type	82							
Junior type	725							

TABLE 2.3.1

GINNERY INVENTORY : MACHINERY

LOCATION : HASAHEISA FACTORY Nr 5

System	Method	Make	Type	Year	Serial Nr	Power	Comment
<b>Power Supply</b>	Blue Nile Grid Transformers						
<b>Seed Cotton Conveying from Yard</b>	Manual loading/unloading contractors tractors/trailers - supplemented with S.G.B. field tractors	Massey-Ferguson					
<b>Conveyance within Ginnery</b>	Manual unloading and emptying of sacks onto outer floor areas behind gin stands.						
<b>s/c Cleaning</b>	Manual feeding into feeder hoppers	Platt	Lattice type		N/A		Good condition, all operational
<b>s/c Conditioning</b>	Atmospheric humidifying, within gin hall.	Mather & Platt	Vortex	1925	N/A	8 KW	Extremely old - difficulty in obtaining spares.
<b>Gin Stands</b>	Roller - 92 No.	Platt	Model 2 Single Acting Single Roller c/w Barakat double stripping rollers		N/A	343 KW	Good condition - well maintained 34 Kgs lint per gin hour Barakat 23 Kgs lint per gin hour on Acala
<b>Cotton Seed Seed Conveying</b>	Mechanical Bucket Elevators	Platts	Shaker conveyor 8 No. Transverse conveyors 2 No. 2 No.		N/A	30 KW 11 KW 15 KW	Good condition Ditto Ditto

<b>Scarto</b>	Seed Gribbles 2 No. Scarto lint recovery - saw gins	Rosedowns Platts	Rotary screen drum 4 x 40x 8" O.D. saw brush gins	N/A N/A	10 KW 15 KW	Good condition Difficulty with spares
<b>Cotton Lint Lint Conveying</b>	Manual loading/unloading into 2 No. trucks running along central aisle to each bale press.					
<b>Lint Conditioning</b>	Manual application		Measured amount of water sprayed via hose.			Poorly applied
<b>Lint Baling</b>	Hydraulic bale presses and mechanical trampers - 2 No. Press Pumps - 2 No.	Platt Lummus	Semi Auto-hydraulic oil up packing presses c/w rotating boxes	N/A	7.5 KW 30 KW 60 KW	Box size 25" c 29" Standard Density 185 kg av.bale 6 Bale Straps

LOCATION: НАЗНАЧЕНА БУКВАРА № 2

С.С.С.Р.

СИМЕРА МАВЕЛОЛА ТИХИМЕКА

## GINNERY INVENTORY : MACHINERY

LOCATION : HASAHEISA FACTORY Nr 6

TABLE 2.3.2

System	Method	Make	Type	Year	Serial Nr	Power	Comment
Power Supply	Blue Nile Grid Transformers						
Seed Cotton Conveying from Yard	Manual loading/unloading contractors tractors/trailers - supplemented with S.G.B. field tractors	Massey-Ferguson					
Conveyance within Ginney	Manual unloading and emptying of sacks onto outer floor areas behind gin stands.						
s/c Cleaning	Manual feeding into feeder hoppers	Platt	Lattice type		N/A		Good condition, all operational
s/c Conditioning	Atmospheric humidifying, within gin hall.	Mather & Platt	Vortex	1925	N/A	8 KW	Extremely old - difficulty in obtaining spares.
Gin Stands	Roller - 92 No.	Platt	Model 2 Single Acting Single Roller c/w Barakat double stripping rollers		N/A	343 KW	Good condition - well maintained 34 Kgs lint per gin hour Barakat 23 Kgs lint per gin hour on Acala
Cotton Seed Conveying	Mechanical Bucket Elevators	Platts	Shaker conveyor 8 No. Transverse conveyors 2 No.		N/A N/A N/A	30 KW 11 KW 15 KW	Good condition Ditto Ditto

**Scarto**

Seed Gribbles 2 No.  
Scarto lint recovery - saw gins

Rosedowns  
Platts

Rotary screen drum  
4 x 40x 8" O.D. saw  
brush gins

10 KW  
15 KW

N/A  
N/A

Good condition  
Difficulty with spares

**Cotton Lint**

Lint Conveying

Manual loading/unloading into 2 No. trucks running along central aisle to each bale press.

Lint Conditioning

Manual application

Measured amount of water sprayed via hose.

Poorly applied

**Lint Baling**

Hydraulic bale press -mechanical trampers - 2 No.

Platt  
Lummus

Semi Auto - hydraulic oil up packing presses c/w rotating boxes

8 KW  
30 KW  
60 KW

N/A  
N/A  
N/A

Box size 25" x 39"  
Standard Density 185 kg av.bale  
6 Bale Straps

СЕМЕЛА ВАСИЛОВА + ИВЧИМЕНКА

ГОСТИНИЦА "КОРНАТОС"

ЛИБИТЕ 5312

TABLE 2.3.3

GINNERY INVENTORY : MACHINERY

LOCATION : HASAHEISA FACTORY Nr 7

System	Method	Make	Type	Year	Serial Nr	Power	Comment
Power Supply	Blue Nile Grid Transformers						
Seed Cotton Conveying from Yard	Manual loading/unloading contractors tractors/trailers - supplemented with S.G.B. field tractors	Massey-Ferguson					
Conveyance within Ginnery	Manual unloading and emptying of sacks onto outer floor areas behind gin stands.						
s/c Cleaning	Manual feeding into feeder hoppers	Platt	Lattice type		N/A		Good condition, all operational
s/c Conditioning	Nil machinery						
	Atmospheric humidifying, within gin hall.	Mather & Platt	Vortex	1925	N/A	8 KW	Extremely old - difficulty in obtaining spares.
Gin Stands	Roller - 92 No.	Platt	80 Model 1 Single Acting Single Roller c/w Barakat double stripping rollers. 12 Model 2		N/A	343 KW	Good condition - well maintained 34 Kgs lint per gin hour
Cotton Seed Seed Conveying	Mechanical	Platts	Shaker conveyor 8 No. Transverse conveyors 2 No. 2 No.		N/A	30 KW 11 KW 15 KW	23 Kgs lint per gin hour on Acala Good condition Ditto Ditto
	Bucket Elevators						

Scarto	Seed Gribbles 2 No. Scarto lint recovery - saw gins	Rosedowns Platts	Rotary screen drum 4 x 40x 8" O.D. saw brush gins	N/A N/A	10 KW 15 KW	Good condition Difficulty with spares
Cotton Lint Lint Conveying	Manual loading/unloading into 2 No. trucks running along central aisle to each bale press.					
Lint Conditioning	Manual application		Measured amount of water sprayed via hose.			Poorly applied
Lint Baling	Hydraulic bale presses - 2 No.	Platt Lummus	1 x Semi Auto - hydraulic 1980 oil up packing presses c/w rotating boxes & Mechanical Trampler  1 x Hydraulic oil up- packing foot tramp	N/A Lint Feeder Tramper Press Pump  N/A Press Pump	8 KW 30 KW 60 KW  60 KW	Box size 25" x 29" Standard Density 185 kg. av.bale 6 Bale Straps

TABLE 2.3.4

LOCATION : HASAHEISA FACTORY Nr 8

GINNERY INVENTORY : MACHINERY

System	Method	Make	Type	Year	Serial Nr	Power	Comment
Power Supply	Blue Nile Grid Transformers						
Seed Cotton Conveying from Yard	Manual loading/unloading contractors tractors/trailers - supplemented with S.G.B. field tractors	Massey-Ferguson					
Conveyance within Ginnery	Manual unloading and emptying of sacks onto outer floor areas behind gin stands.		Lattice type		N/A		Good condition, all operational
s/c Cleaning	Manual feeding into feeder hoppers						
s/c Conditioning	Nil machinery						
Gin Stands	Atmospheric humidifying, within gin hall.	Mather & Platt	Vortex	1925	N/A	8 KW	Extremely old - difficulty in obtaining spares.
	Roller - 92 No.	Platt	80 Model 1 Single Acting Single Roller c/w Barakat double stripping rollers 12 Model 2.		N/A	343 KW	Good condition - well maintained 34 Kgs lint per gin hour Barakat 23 Kgs lint per gin hour on Acala
Cotton Seed Seed Conveying	Mechanical Bucket Elevators	Platts	Shaker conveyor 8 No. Transverse conveyors 2 No.	2 No. 2 No.	N/A N/A N/A	30 KW 11 KW 15 KW	Good condition
							Ditto
							Ditto

**Scarto**  
 Seed Gribbles 2 No.  
 Scarlo lint recovery - saw gins

**Cotton Lint**  
 Lint Conveying  
 Manual loading/unloading into 2 No. trucks running along central aisle to each bale press. Fed by inclined cleaner.  
 Manual application

**Lint Conditioning**  
 Measured amount of water sprayed via hose.

**Lint Baling**  
 Hydraulic bale presses and mechanical tramper - 2 No.  
 Press Pumps - 2 No.

**Rosedowns**  
 Platts

**Rotary screen drum**  
 4 x 40x 8" O.D. saw brush gins

**Lint Feeders**  
 Trampers

**Tramper**  
 1980

**Platt**  
 Lummus

**Semi Auto - hydraulic oil up packing presses**  
 c/w rotating boxes

**Box size 25" x 39"**  
 Standard Density 185 kg av.bale  
 6 Bale straps

**10 KW**  
**15 KW**

**N/A**  
**N/A**

**N/A**  
**N/A**

**N/A**  
**N/A**

**N/A**  
**N/A**

**60 KW**

**Good condition**  
**Difficulty with spares**

**Poorly applied**

COLUUSUT

LOMEL

YSEL 2218114

LYBE

YAYE

WETIOL

PLATEU

FOCVLION : HVZVHEBY LVCLIOGA VP-10

LVBE 5'3'2

СІМБЕЛІ ВАМІЛОЛІА : ІНУСІНІМЕКА

## GINNERY INVENTORY : MACHINERY

LOCATION : HASAHEISA FACTORY Nr 10

TABLE 2.3.5

System	Method	Make	Type	Year	Serial Nr	Power	Comment
Power	Blue Nile Grid Transformers						
Seed Cotton							
s/c Conveying in Yard	Contractors tractors & trailers supplemented by SGB tractors	Massey Ferguson					
s/c Conveying in ginnery	Hand fed into pneumatic/mechanical system 2 No. mixing rooms, underfloor feeding points	Murray	Size 35 Suction Fans 2 No.	1954	N/A	45 KW	Good condition & operation
		"	Air separators 2 No.	"	N/A	12 KW	Ditto
		"	Screw Conveyors 2 No. Auto feeders 20 No.	"	N/A	12 KW	Ditto
s/c Conditioning	Nil	"	Overflow pens 2 No.		N/A		Ditto
s/c Cleaning	Nil machinery						Some dust extraction from separators/suction system
Gin Stands	Roller - 20 No.	Platts	Model 2 Single Acting Single roller c/w Barakat double stripper.		N/A	75 KW	Good condition & operation
Cotton Seed	Mechanical Conveyors	Murray	Shaker Conveyors Bucket elevators	1954	N/A	10 KW 6 KW	Good condition & working order

Item	Description	Manufacturer	Year	Power	Status	
Seed Dressing	Heat sterilizer & rotary drum seed treater - direct feeding of cotton seed from ginnery production	Simons	1944	N/A	Effective but obsolete system. Worn out	
				10 KW		
Cotton Lint	Lint Conveying	Murray	Lint drag belts in front of gin stands 2 No.	N/A	Good condition & operation	
			Condenser	N/A	Ditto	
		V/A Fan	N/A	10 KW		
		PCX double box, rotating, up-packing oil hydraulic press c/w mechanical tramper	Murray	1944	Tramper Pump	Good condition & operation
Lint Baling	Hydraulic bale press	Murray		N/A	15 KW	
				N/A	30 KW	

СИМЕНА ДИМЕДИОНА - ИМЧИНИЕВА  
 КОМУНИКАЦИОННИ ЛИНЕИ И КАБЕЛИ  
 КОМУНИКАЦИОННИ ЛИНЕИ И КАБЕЛИ

TABLE 2.3.6

LOCATION : HASAHEISA FACTORY Nr 12

## GINNERY INVENTORY : MACHINERY

System	Method	Make	Type	Year	Serial Nr	Power	Comment
Power Supply	Blue Nile Grid Transformers						
Seed Cotton Conveying within Yard	Contractors tractors/trailers supplemented by SGB field tractors	Massey Ferguson					
Conveying within Ginnery	Pneumatic/mechanical. s/c fed into 4 No. mixing room suction pipes and delivered to separators and Conveyors	Davidson	Scitrocco suction fans 4 - No.	1964	N/A	120 KW	Good condition
		Platts	Air Separators - 4 No.		N/A	22 KW	Ditto
		"	Separator feed controls 8 No.		N/A	4 KW	
		Platts	Screw conveyors 8 No.	"	N/A	30 KW	Ditto
			Overflow conveyors 4 No.	"	N/A	10 KW	
			Auto feeders 92 No.				
s/c Cleaning	Nil machinery						Fine dust only removed in pneumatic suction system
s/c Conditioning	Atmospheric humidification	Mellor Bromley	Multiple fan blower units located throughout factory. 56 No. Water pumps 6 No.	"	N/A	30 KW 18 KW	Poor design layout results in continual drain blockages caused by lint fly. Rarely in use
Gin Stands	Roller - 92 No.	Platts	Model 2 Single Acting single roller c/w Barakat double stripper	1964	N/A	34.3 KW	Good condition and operation

<b>Cotton Seed</b> Seed Conveying	Underfloor conveyors Elevators	Platts	Shaker conveyors 12 No. Bucket 2 No.	1964	N/A	60 KW 20 KW	Good condition and operation Ditto
	Rotary drum seed/s.c. separator	Rosedowns	2 section screen 2 No.	"	N/A	15 KW	4 Bagging points
Lint Recovery	Saw Gins	Platts	40 x 8" OD saw brush gins - 4 No.	"	N/A	15 KW	Fair condition - spare parts problem.
<b>Cotton Lint</b> Lint Conveying	Mechanical - below gin stands	"	Conveyor Belts	"	N/A	9 KW	Good condition and operation
	Condensers - 2 No.	Platt Lummus	Revolving drum 40" x 50"	"	N/A	4 KW	Ditto
	Lint pull fans	"	V.A. Fans - 2 No.	"	N/A	20 KW	Ditto
	Lint feeders to bale press	"	Kicker paddle	"	N/A	8 KW	Ditto
Lint conditioning	Lint slide spray	Kemgas	Statifier sprays	"	N/A	2 KW	
Lint Baling	Hydraulic Bale presses 2 No.	Platt Lummus	Hydraulic oil up packing semi auto bale press c/w mechanical tramper	1964	N/A Trampers Press Pumps	30 KW 60 KW	Good condition and operation

TABLE 2.3.7

LOCATION: HASAHEISA FACTORY Nr 13

GINNERY INVENTORY : MACHINERY

System	Method	Make	Type	Year	Serial Nr	Power	Comment
Power Supply	Blue Nile Grid Transformers						
Seed Cotton s/c Conveying in Yard	Contractors tractor/trailers supplemented by SGB tractors	Massey Ferguson					
s/c Conveying in ginnery	Manual unloading & emptying of sacks behind gin stands						
	Manual feeding into gin hoppers						
s/c cleaning	Nil machinery						
s/c Conditioning	Atmospheric humidification	Mather & Platt	Vortex - multiple open sprays into gin hall	1950	N/A Pump	10 KW	Many sprayers non-operational for lack of spares.
Gin Stands	Roller - 46 No.	Platt	Model 1 Single Roller Single Acting c/w Barakat double stripper		N/A	157 KW	Obsolete models
Caton Seed Seed Conveying	Mechanical conveyors below gin stands	Platt	Shaker conveyors 4 No.	1950	N/A	15 KW	Good condition & operation
			Bucket elevator			5 KW	Ditto
Scarto	Seed Gribbles - 1 No. Scarto lint recovery - saw gins Manual bagging of lint	Rosedowns Platt	Rotary screen drum 40 x 8" OD Saw brush gins - 2 No.		N/A	10 KW 8 KW	Good condition Fair condition - spares problem

**Cotton Lint**  
Lint conveying

Manual - by central hand pushed trucksto bale presses

**Lint Conditioning**

Manual application

**Lint Baling**

Hydraulic presses - 2 No.

Hand spraying

Hydraulic Engineering  
Manual fed, up-packing water hydraulic press

Lindemann  
Manual fed up-packing double box, oil hydraulic bale press

Brush Transformer Co.  
3 x 750 kVA, 11 000/433 V  
Year of manufacture 1962

Year of manufacture 1965  
3 x 120 kVA, 11 000/433 A  
Brush Transformer Co.

N/A 20 KW

Poorly applied  
Obsolete  
Standard density

English Electric Co.  
1 x 750 kVA, 11 000 V  
Year of manufacture 1965

N/A 20 KW

Obsolete  
Standard density

Year of manufacture 1965  
3 x 120 kVA, 11 000/433 A  
Brush Transformer Co.  
AET Co.  
2 x 1 250 kVA, 11 000/433 V

Year of manufacture 1965  
3 x 120 kVA, 11 000/433 A  
Brush Transformer Co.

Year of manufacture 1965  
3 x 120 kVA, 11 000/433 A  
Brush Transformer Co.

collection  
transformer at  
Factory No 10

TABLE 2.4

LOCATION: HASAHEISA

GINNERY INVENTORY: POWER SUPPLY

Power supply	HV switchgear	LV switchgear	Distribution transformers	Power factor correction
NEC-11kV	<p>English Electric Co. type OLX, 11 kV, 250 MVA, 400 A 2 Nr oil circuit breakers Serial Nr: EGM 6781.1.A EGM 6781.1.F 1 Nr bus-section oil switch, 400 A, 250 MVA Serial Nr: 6781/1/D 2 Nr off-load isolators</p>	<p><b>Factory Nr 5</b> Crompton Parkinson Co. 415 V, 1 200 A 800A, air circuit breakers type ABM, Serial Nr: 99357/60 99363/60 1200 A bus-section isolator type ABM, Serial Nr: 99367/60</p>	<p>Brush Transformer Co. 2 x 750 kVA, 11 000/433 V Year of manufacture 1962</p>	<p>BICC 2 x 65 kVAR STC 2 x 63 kVAR</p>
	<p>English Electric Co. type OLX, 11 kV, 250 MVA, 400 A 2 Nr oil circuit breakers Serial Nr: EGM 6781/2A EGM 6781/2G 1 Nr bus-section oil switch, Serial Nr EGM 6781/2D 2 Nr off-load isolators</p>	<p><b>Factory Nr 6</b> Crompton Parkinson Co. 415 V, 1 200 A type ABM air circuit breakers Serial Nr: 99365/60 800 A 99355/60 800 A bus-section isolator type ABM 1 200A Serial Nr 99359</p>	<p>Brush Transformer Co. 2 x 750 kVA, 11 000/433 V Year of manufacture 1962</p>	<p>BICC 2 x 65 kVAR STC 2 x 65 kVAR</p>
	<p>English Electric Co. type OLX, 11 kV, 250 MVA, 400 A 4 Nr oil circuit breakers Serial Nr: EGP 7601/1A EGP 7601/1G EGP 7601/C15 EGP 7601/- 1 Nr bus-section oil switch 2 Nr off-load isolators</p>	<p><b>Factory Nr 7</b> Crompton Parkinson Co. 415 V, 1 200 A, type ABM 800 A, air circuit breakers Serial Nr: 102589/62 102592/62 bus-section isolator 1 200 A Serial Nr: 102591/62</p>	<p>Brush Transformer Co. 2 x 750 kVA, 11 000/433 V Year of manufacture 1962</p>	<p>BICC 2 x 65 kVAR STC 2 x 63 kVAR</p>

English Electric Co.  
11 kV, 250 MVA, 400 A  
2 Nr oil circuit breakers  
Serial Nr:  
EGP 7601/2A  
EGP 7601/2E  
1 Nr bus-section switch  
2 Nr off-load isolators

**Factory Nr 8**  
Crompton Parkinson Co.  
415 A, 1 200 A, type ABM  
800 A, air circuit breakers  
Serial Nr:  
102597/62  
102600/62  
1 200 A bus-section isolator  
Serial Nr: 102599/62

Brush Transformer Co.  
2 x 750 kVA, 11 000/433 V  
Year of manufacture 1962  
BICC 2 x 65 kVAR  
STC 2 x 65 kVAR

LV switchgear only

**Factory Nr 10**  
English Electric Co.  
415 V combination fuse  
switchboard with  
TP & N busbar  
1 x 400 A incomer  
1 x 300 A incomer

English Electric Co.  
1 x 750 kVA, 11 000/433 V  
None

AEI Co.  
type IB, 11 kV, 400 A, 250 MVA  
2 Nr oil circuit breakers  
Serial Nr:  
62163  
62165  
1 Nr bus-section switch  
type BVP 3, 400 A,  
Serial Nr 62164  
2 Nr oil switches  
Serial Nr:  
71194  
62162

**Factory Nr 12**  
AEI Co.  
2 x 500 A incomers  
1 x 500 A bus-section  
isolator

AEI Co.  
2 x 1 250 kVA, 11 000/433 V  
BICC 8 x 60 kVAR

LV switchgear only

**Factory Nr 13**  
MEM & English Electric Co.  
415 V combination fuse  
switchboards (3 Nr) with  
TP & N busbar  
3 x 200 A incomers

Power supply taken from  
the distribution  
transformer at  
Factory Nr 10  
None

**GINNERY INVENTORY:BUILDINGS**

LOCATION: BAGEIR

**TABLE 3.1**

Building	Description	Approximate dimensions L x W x H (m)	Comments
Main Buildings Ginning factories Nr 13	Structure : steel frame	130 x 30 x 7	In good condition, no remedial works required.
	Walls : GCI sheeting		
	Roof : GCI sheeting		
	Floor : concrete		
Office	Structure : concrete frame	20 x 12 x 4	In good condition, no remedial works required.
	Walls : brickwork		
	Roof : cement tiles		
	Floor : concrete		
Main store	Structure : steel frame	105 x 35 x 8	Generally in good condition, some maintenance to wind-damaged GCI sheeting required. Store is not only for ginnery use but is presently used for storage of agricultural inputs, etc.
	Walls : 3 m high brickwork and GCI sheeting		
	Roof : GCI sheeting		
	Floor : concrete		
Other Buildings Fire office and station	Brickwork with GCI roofing	various	In good condition, no remedial works required.
Amenity buildings			
GLR offices			

TABLE 3.2

LOCATION: BAGEIR

GINNERY INVENTORY: INFRASTRUCTURE

Facility	Description	Comments						
Water Supply	A ring fire canal provides water for 10 Nr 5 000 gallon ground tanks for yard firefighting. Two 90 m deep wells provide water via an 18 m high tank (24 000 gallons) for the factory sprinkler system. One of the wells is also connected to the domestic water supply system.	Firefighting system is adequate.						
(a) Firefighting								
(b) Domestic and other uses	One 90 m deep well provides water via 18 m high tank (10 000 gallons). This tank also receives water from one of the firefighting wells. Water is distributed by galvanised steel pipe system.	A shortage of domestic water is reported.						
Surface Water Drainage	No special provisions are made.	Some drainage problems in northwest of factory yard. Sump for pumping to fire canal is required.						
Sewage Disposal	Bucket latrines.							
Roads/Access	There are no surfaced roads within the site and no all-weather connection to the main Khartoum/Wad Medani road (2 km). Gezira Light Railway and Sudan Railways system.							
Fencing	Barbed wire and steel angle posts.	In good condition.						
Platforms and Hardstandings	Three 20 x 30 m concrete hardstandings. Platform 30 x 15 m at each end of factory.	In good condition.						
Houses	Adjacent to the factory site there are the following houses owned by SGB :  <table border="1" style="margin-left: 20px;"> <tr> <td>Senior type</td> <td>12</td> </tr> <tr> <td>Middle type</td> <td>53</td> </tr> <tr> <td>Junior type</td> <td>151</td> </tr> </table> Construction is of brick, jack arch or GCI sheeting roofs, concrete tile floors. Sanitation is by water-borne sewage with septic tanks and aqua privies.	Senior type	12	Middle type	53	Junior type	151	In good condition. All houses are occupied by ginnery staff except 11 which are occupied by persons connected with ginnery, i.e. medical officer, police, teachers. Other buildings in the housing area include dispensary, co-operative shop, police post, recreation centre.
Senior type	12							
Middle type	53							
Junior type	151							

TABLE 3.3

## GINNERY INVENTORY : MACHINERY

LOCATION : BAGEIR

System	Method	Make	Type	Year	Serial Nr	Power	Comment
Power Supply	Blue Nile Grid Transformers						
Seed Cotton Conveying within Yard	Contractors tractors/trailers supplemented by SGB field tractors	Massey Ferguson					
Conveying within Ginney	Pneumatic/mechanical. s/c fed into 4 No. mixing room suction pipes and delivered to separators and Conveyors	Davidson Platts "	Scitrocco suction fans 4 - No. Air Separators - 4 No. Separator feed controls 8 No.	1964	N/A N/A N/A	120 KW 22 KW 4 KW	Good condition Ditto
s/c Cleaning	Nil machinery	Platts	Screw conveyors 8 No. Overflow conveyors 4 No. Auto feeders 92 No.	" "	N/A N/A	30 KW 10 KW	Ditto
s/c Conditioning	Atmospheric humidification	Mellor Bromley	Multiple fan blower units located throughout factory. 56 No. Water pumps 6 No.	"	N/A	30 KW 18 KW	Fine dust only removed in pneumatic suction system Poor design layout results in continual drain blockages caused by lint fly. Rarely in use
Gin Stands	Roller - 100 No.	Platts	Model 2 Single Acting single roller c/w Barakat double stripper	1964	N/A	373 KW	Good condition and operation

Cotton Seed Seed Conveying	Underfloor conveyors Elevators	Platts	Shaker conveyors 12 No. Bucket 2 No.	1964	N/A	60 KW 20 KW	Good condition and operation Ditto
	Rotary drum seed/s.c. separator	Rosedowns	2 section screen 2 No.	"	N/A	15 KW	4 Bagging points
Lint Recovery	Saw Gins	Platts	40 x 8" OD saw brush gins - 4 No.	"	N/A	15 KW	Fair condition - spare parts problem.
Cotton Lint Lint Conveying	Mechanical - below gin stands	"	Conveyor Belts	"	N/A	9 KW	Good condition and operation
	Condensers - 2 No.	Platt Lummus	Revolving drum 40" x 50"	"	N/A	4 KW	Ditto
	Lint pull fans	"	V.A. Fans - 2 No.	"	N/A	20 KW	Ditto
	Lint feeders to bale press	"	Kicker paddle	"	N/A	8 KW	Ditto
Lint conditioning	Lint slide spray	Kemgas	Statifier sprays	"	N/A	2 KW	
Lint Baling	Hydraulic Bale presses 2 No.	Platt Lummus	Hydraulic oil up packing semi auto bale press c/w mechanical tramper	1964	N/A Trampers Press Pumps	30 KW 60 KW	Good condition and operation



GINERY INVENTORY INFRASTRUCTURE

Comments	Description	Dimensions
Subject to frequent interruptions of supply.	From municipal supply one 3 500 ground tank for yard fire-fighting with fire tender and hose and sprinkler system.	
Subject to frequent interruptions of supply.	Fire hydrant connected to main.	
No problems reported due to adequate natural drainage.	From municipal supply.	11 x 1 x 4'2 (1 M)
Subject to frequent interruptions of supply.		30 x 10 x 4'2 (1 M)
Old and in poor condition, provides little water for extra dry areas and maintenance.	Concours filter	30 x 12 x 4
The gynecology of the olefin and various equipment in good condition is collected water technology.	No for... access to site at which site. Sider Roll-... Distributed steel angle posts. OCI equipment OCI equipment OCI equipment	
in good condition. Other staff housed in private accommodation in Senap town.	1 100 m <sup>2</sup> concrete loading platform 0.7 m high 3 500 m <sup>2</sup> hardstanding in 6 acres by 0.3 m well Distributed.	1 x 1 x 1 (w) 3 x 1 x 1 (w) Distributed
	One senior house for manager.	

GINERY INVENTORY INFRASTRUCTURE

TABLE 4.1

LOCATION: SENNAR

GINNERY INVENTORY: BUILDINGS

Building	Description	Approximate dimensions L x W x H (m)	Comments
<b>Main Buildings</b> Ginning factory	Structure : steel framed stanchions and trusses	68 x 50 x 65	In good condition, no remedial works required. The dimensions given are overall and include additions to the main building which have been made to accommodate 10 extra gin stands and workshop.
	Walls : GCI sheeting		
	Roof : GCI sheeting		
	Floor : concrete		
Office	Structure : load bearing brickwork	30 x 13 x 4	In good condition, no remedial works required.
	Roof : concrete		
	Floor : concrete tiles		
Stores 2 Nr	Structure : steel framed	20 x 10 x 4.5 (1 Nr)	Both in good condition, no remedial works required.
	Walls : GCI sheeting		
	Roof : GCI sheeting	11 x 7 x 4.5 (1 Nr)	
	Floor : concrete		
<b>Other Buildings</b> Latrines Contractor office Mech. Supervision office Pump house Abstraction block	Brick built	various	In good condition, no remedial works required.

TABLE 4.2

LOCATION: SENNAR

## GINNERY INVENTORY: INFRASTRUCTURE

Facility	Description	Comments
<b>Water Supply</b>		
(a) Firefighting	From municipal supply one 3 500 ground tank for yard fire-fighting with fire tender and hoses and sprinkler system. 1 Nr hydrant connected to mains.	Subject to frequent interruptions of supply.
(b) Domestic and other uses	From municipal supply.	Subject to frequent interruptions of supply.
<b>Surface Water Drainage</b>	No special provisions.	No problems reported due to adequate natural drainage.
<b>Sewage Disposal</b>	Bucket latrines.	
<b>Roads/Access</b>	No surfaced road access to site or within site. Sudan Railways system connects to site.	
<b>Fencing</b>	Barbed wire and steel angle posts.	Old and in poor condition, provides little security.
<b>Platforms and Hardstandings</b>	780 m <sup>2</sup> concrete hardstanding adjacent to mixing and seed rooms. 1 100 m <sup>2</sup> concrete loading platform 0.7 m high. 8 500 m <sup>2</sup> hardstanding in 6 areas by 0.3 m wall with sand and gravel infill.	All in good condition.
<b>Houses</b>	One senior house for manager.	In good condition. Other staff housed in private accommodation in Sennar town.

TABLE 4.3

LOCATION : SENNAR

## GINNERY INVENTORY : MACHINERY

System	Method	Make	Type	Year	Serial Nr	Power	Comment
Power Supply	Blue Nile Grid Transformers	Brush	11,000/415V	1962	61538	300 KVA	Supplies part electrification of ginnery.
	Diesel - direct drive via clutch	Ruston	Size 6 Class VEB 500 RPM		413007		Engine running at 470 RPM to regulate speed of gin rollers.
	Line shaft drive via clutch	Wigglesworth	No. 3		N/A		
	Air start compressor	Ruston	Mark 6PS 560 RPM Petrol Engine.		408376		Condition/operation satisfactory
	Lighting Plant - Engine Alternator	Lister Lister	46 cyl. water cooled CMR 415/240V	1958	Plant No.53029A FDQ 82 A169	24 KW	Condition good.
	Diesel - Direct Drive thro' countershafts	Allen	3 Cyl. Burmeister & Wain Air Blast Semi-Diesel 200 RPM	1926	5	180 KW	This engine was replaced by the Ruston as prime mover but is in every way intact and operational - including spares.
	Diesel - Direct Drive thro' countershafts	Allen	Single Cylinder Hot bulb type	1926	N/A		Still in use - driving workshop machinery.
Seed Cotton Conveying from Yard	Manual loading/unloading tractor/trailers 2 No.	Nuffield					15 Sacks s/c per trailer - high level.

Conveying within Ginnery	Manual feeding into multiple points within 2 mixing rooms located in either side of ginnery via 2 overhead Separator/Vac. wheels, to central area	N/A	s/c Suction Fans (1) (2)	N/A	N/A	45 KW 45 KW	Mixing room system no longer in use. Mods. to s/c distribution from separators required.
	Manual feeding to auto feed hoppers	Murray	72" Separator/Vac.wheels	N/A	N/A	8 KW 8 KW	Condition-operation satisfactory
S/C Cleaning	Nil Machinery	Platts	lattice Feeders	1962			
S/C Conditioning	Overhead sprays in gin hall	Mather & Platt	Vortex 2 cylinder horizontal pump.	N/A	N/A	N/A	Out of use - defunct
Gin Stands	Roller - 60 No.	Platts	40 Model 1 20 Model 2 S.A.S.R. c/w double stripper.			133 KW	49 gin stands powered from Ruston driven central line shaft. 11 gin stands from 3 KW electric motors from mains supply. Congested layout at one end of ginnery, where electric powered gins installed.
Cotton Seed C/S Conveying	Mechanical conveyors below gin stands in basement	N/A	Shaker conveyors below 49 gin stands. Screwconveyors below extended 12 gin stands.			20 KW 4 KW	Condition/operation good OK
	Bucket Elevators Gribble	N/A	Rotary drum screens	N/A	N/A		Condition/operation satisfactory No trash removal screens fitted

TABLE 4.3 (cont.)

LOCATION : SENNAR

GINNERY INVENTORY : MACHINERY

System	Method	Make	Type	Year	Serial Nr	Power	Comment
Scarto Scarto handling	Conveyors - Scarto	N/A	Shaker Conveyor				Condition/operation OK
	Conveyors - recovered seed		"				"
	Saw Gins - manual lint collection	Platt	40 Saw x 8" dia. brush 100 saw x 12" delinter	N/A N/A			Saws and Saw Bars require attention.
Cotton Lint Lint conveying	Manually loaded onto central flat belt conveyor - Lint deposited on farfara platform.		Locally made			4 KW	
	Manual spraying						Poorly applied.
Lint Baling	hydraulic tramper and bale press, rotating double boxes, manual loading of lint.	J. Shaw	Hydraulic Oil down-packing tramper.	1957	Order No. 3886		All in good working order
		"	3 1/2" OD ram x 11'6" stroke - WP 300 lbs/sq.in				Box size 25" x 39" x 12'6" 420 lb (190kg) av.bale wt. 30 lbs. cu.ft.(80 kgs/cu.m.)
		"	Hydraulic oil up-packing press - 310 ton 3 x 71/4" OD rams 11'6" stroke 12" to 7.1/4" OD rams x 5'0" stroke.		Order No. 3885		Standard Density 6 Bale Straps Spares problem.
Fire Fighting	Intensifier				N/A		
	Factory sprinkler system	Mather & Platt	Compressed air/water cylindrical tanks 2190 x 12600		N/A		Reported to be in working order.
	Compressor Water Pump	Reavell N/A	Axial type 650 RPM Centrifugal		17396 N/A	2 KW	" W
Workshops			Centre Lathe 360 x 2800				Adequate
			Roller Lathe				"
			Drill machines				"
			Welding machines				"

TABLE 4.4

GINNERY INVENTORY: POWER SUPPLY

LOCATION: SENNAR

Power supply	HV switchgear	LV switchgear	Distribution transformers	Power factor correction
<p>NEC-11 kV Emergency standby: Lister/Crompton Parkinson diesel generator set, 24.37 kVA (for lighting and lint belt drive motor)</p>	<p>Long and Crawford (owned by NEC) 11 kV, outdoor ring main unit 400/400/100A, 250 MVA</p>	<p>AEI 415 V combination fuse switch-board with TP &amp; N busbar chamber</p>	<p>Brush 1961/62 1 x 300 kVA, 11 000/433 V</p>	

Comments: No housing problems are reported.

TABLE 5.1

LOCATION: HAMADNALLAH

GINNERY INVENTORY: BUILDINGS

Building	Description	Approximate dimensions L x W x H (m)	Comments
<b>Main Buildings</b> Ginning factory	Structure : steel framed pipe trusses and stanchions Walls : 2.5 m brickwork and asbestos cement sheeting Roof : asbestos cement sheeting Floor : concrete	110 x 27 x 6.5	In good condition, no remedial works required.
Office	Structure : load bearing brickwork	30 x 12 x 4	In good condition, no remedial works required.
Stores 2 Nr	Structure : steel framed Walls : GCI sheeting Roof : GCI sheeting Floor : concrete	30 x 10 x 4.5 (1 Nr) 25 x 10 x 4.5 (1 Nr)	In good condition, no remedial works required.
<b>Other Buildings</b> Contractors office Fire fighting office Workshop Pump house Latrines Gate room	Brickwork and GCI roofing	various	In good condition, no remedial works required.

TABLE 5.2

LOCATION: HAMADNALLAH

## GINNERY INVENTORY: INFRASTRUCTURE

Facility	Description	Comments						
<b>Water Supply</b>	Source and storage same as domestic supply. Tank feeds 8 Nr 1 inch standpipes in factory and stores. Yard firefighting is from fire canal using tenders and hoses.	Firefighting system is adequate.						
(a) Firefighting								
(b) Domestic and other uses	2 Nr 42 m deep wells provide water to 17.5 m high tank (30 000 gallons). Water distributed by galvanised steel pipes to factory and residential area.	No problems reported.						
<b>Surface Water Drainage</b>	No special provisions are made.	No problems reported. Adequate natural drainage to adjacent low ground.						
<b>Sewage Disposal</b>	Aqua privies.							
<b>Roads/Access</b>	Gravel road connects factory with residential area. No other surfaced roads to or within site. Sudan Railways siding.							
<b>Fencing</b>	Barbed wire and steel angle posts.	In good condition.						
<b>Platforms and Hardstandings</b>	4 800 m <sup>2</sup> hardstanding in 5 areas formed by 0.2 m high wall infilled with sand and gravel. 750 m <sup>2</sup> 0.7 m high concrete loading platform	In good condition.						
<b>Houses</b>	Adjacent to the factory site there are the following houses :  <table border="1"> <tr> <td>Senior type</td> <td>6</td> </tr> <tr> <td>Middle type</td> <td>5</td> </tr> <tr> <td>Junior type</td> <td>37</td> </tr> </table> <p>in brickwork (except 2 senior houses which are in pre-fabricated sheet). Senior and middle houses have concrete roofs, junior houses GCI roofs. Sanitation is by water privies and water-borne sewage systems and septic tanks.</p>	Senior type	6	Middle type	5	Junior type	37	No housing problems are reports.
Senior type	6							
Middle type	5							
Junior type	37							

LOCATION : HAMADNALLAH

TABLE 5.3

GINNERY INVENTORY : MACHINERY

System	Method	Make	Type	Year	Serial Nr	Power	Comment
Power Supply	Direct drive diesel engine transmitting power via Clutch and line shafts.	Ruston	Size 7 Class VCB 500 RPM		379315	400 H.P.	Operation/condition good
	Clutch	Wigglesworth	Size 3				OK
Power Supply	Diesel Generators	(1) Ruston Diesel British Thompson Houston	Size 3 Class VCB 600 RPM Type RF 10536 415/249V.		387343	100 H.P.	Operation/condition good
		(2) Ruston Diesel B.Th.H.	Size 3 Class VCB 600 RPM RF 10536 415/240V		383215	100 H.P.	" "
	Alternator	(3) Ruston Diesel B.Th.H.	Size 3 Class VCB 600 RPM RF 10536 415/240V.		B474427/1/01	74 KVA	" "
		(4) Ruston Diesel Electric Construction (Wolves)	Size 3 Class VCB 600 RPM 600V.		387342	100 H.P.	" "
Starting air compressor	Alternator	(3) Ruston Diesel B.Th.H.	Size 3 Class VCB 600 RPM RF 10536 415/240V.		B474427/1/03	74 KVA	" "
		(4) Ruston Diesel Electric Construction (Wolves)	Size 3 Class VCB 600 RPM 600V.		421484	100 H.P.	Operation/condition good
Starting air compressor	Alternator	(3) Ruston Diesel B.Th.H.	Size 3 Class VCB 600 RPM RF 10536 415/240V.		258664	74 KVA	" "
		(4) Ruston Diesel Electric Construction (Wolves)	Size 3 Class VCB 600 RPM 600V.		387431/2	3 KW	OK



TABLE 5.3 (cont.)

LOCATION: HAMADNALLAH

GINNERY INVENTORY : MACHINERY

System	Method	Make	Type	Year	Serial Nr	Power	Comment
Cotton Seed	Mechanical conveying below gin stands in basement.	N/A	Shaker conveyors				
	Gribble	N/A	Bucket elevator 2 drum screens c/w single bagging spout			18 KW	No trash removal screens fitted
	Recovered c/s Recovered lint - manual	Platts	Shaker conveyor 2 x 40 x 8" OD Saw brush gins.				Operation otherwise good
Cotton Lint Lint Conveying	Manual loading onto 2 trucks along outer wings of gin rows. Manual unloading onto farfara platform.	N/A					Unsatisfactory system
Lint Conditioning	Manual spraying	J. Shaw	Hydraulic oil down packing tramper 31/2" OD ram x 11'6" stroke @ 300 lbs/0" W.P.				Poor application.
Lint Baling	Hydraulic tramper and bale press, rotating double boxes lint manually loaded	D. Brown	Roloid gear pump Size 4H.		427834		Operation/condition good Spares problem
	Tramper pump	J. Shaw	Hydraulic oil up-packing bale press 3 x 7.1/4 OD rams x 11'6" stroke @ 300 ton WP				
	Press Pump	Hastie Albany	Pump size P12				N/A

<b>Water Supply</b>	Borehole Storage Tank	Braithwaite	134,000 litre cap. 17500 A.G.L.	Condition good
	via diesel pump from fire canal	Leyland	N/A	
<b>Fire Fighting</b>	Sprinkler system within factory	Mather & Platt	Auto start pump Type 5/2 ST MEDI 625 g.p.m. 230' hd. 1700 rpm.	Suffering from neglect. Appears to be in good condition otherwise. Doubtful whether operational.
	Fire Tender	Mercedes	Storage water tank hoses etc.	Operation
	Mobile pump unit	Coventry Climax/ Godiva	Towed	Operational
	Maintenance	N/A	Eng.No. FW 6642 Pump No. FWP 6642	Adequate
<b>Luggatta</b>	Manual recovery	Local	Centre Lathe 3000 bed x 250 swing Welding Equipt. Gas & Electric Pillar Drill Knife grinder etc. 4 No. rotary screen drums.	Slow but effective cleaning.

TABLE 5.4

GINNERY INVENTORY: POWER SUPPLY

LOCATION: HAMADNALLAH

Power supply

Distribution transformers

Power factor correction

LV switchgear

415 V, 400A, BTH, type V, form MI, enclosed with 415 V combination fuse switchboard with TP & N busbar off main busbar

Private generation:  
 4 x 75 kVA,  
 415/240 V,  
 0.85 pf,  
 600 rpm.  
 (3 x BTH  
 1 x ECCo.)  
 1954 approx.

Equipment	Quantity	Year	Manufacturer	Notes
Power supply	1			
Private generation	4			
4 x 75 kVA, 415/240 V, 0.85 pf, 600 rpm. (3 x BTH 1 x ECCo.) 1954 approx.				
Distribution transformers	1			
Power factor correction				
LV switchgear	1			
415 V, 400A, BTH, type V, form MI, enclosed with 415 V combination fuse switchboard with TP & N busbar off main busbar				



TABLE 6.1

GINNERY INVENTORY: BUILDINGS

Building	Description	Approximate dimensions L x W x H (m)	Comments
Main Buildings Ginning factory Nr 1	Structure : steel stanchions and tubular trusses	105 x 15 x 7	Some heave of floor slabs has occurred but remedial works are not required unless undertaken as part of general factory modernisation.
	Walls : 2 m brickwork and GCI sheeting		
	Roof : GCI sheeting		
	Floor : concrete		
Ginning factory Nr 2	Structure : steel framed, portal	35 x 15 x 7.5	Some cracking of floor slabs and maintenance required. 25% cladding needs replacement.
	Walls : 0.6 m brickwork and GCI sheeting		
	Roof : GCI sheeting		
	Floor : Concrete		
Ginning factory Nr 3	Structure : Steel framed, portal	54.5 x 15.5 x 6.5	In good condition, no remedial works required.
	Walls : 3 m brickwork and aluminium cladding		
	Roof : GCI sheeting		
	Floor : Concrete		
Seed room (factory Nr 3)	As factory Nr 3	18.5 x 12 x 6.5	In good condition, no remedial works required.
Mixing room (factory Nr 3)	As factory Nr 3	25 x 15.5 x 6.5	In good condition. Doors require refixing.
Power room (factory Nr 3)	As factory Nr 3	12 x 9 x 6.5	In good condition, no remedial works required.
Offices (2 blocks)	Structure : load bearing brickwork	30 x 8 x 4 20 x 8 x 4	In good condition, no remedial works required.
	Roof : GCI sheeting		
	Floor : concrete tiles		
Stores 3 Nr	Structure : concrete columns and beams, steel trusses	80 x 20 x 4 (2 Nr) 36 x 9 x 4 (1 Nr)	In good condition (but floor requires to be concreted).
	Walls : Brick		
	Roof : GCI sheeting		
	Floor : earth		
Spare parts store	As factory Nr 1		In good condition, no remedial works required.
Other Buildings Latrines Dispensary Gate house Firefighting office Workshop shed	Brickwork and GCI roofing	various	Reasonable condition.

TABLE 6.2

GINNERY INVENTORY:INFRASTRUCTURE

LOCATION:KASSAB

Facility	Description	Comments
Water Supply (a) Firefighting	Source is well (see below) and 17 000 gallon storage tank which feeds 36 hydrants in factory yard and hose reels in Nr 1 and Nr 2 the factories. CO <sub>2</sub> cylinders provided in factory Nr 3.	No hydrants are provided in factory Nr 3.
(b) Domestic and other uses	Two wells in factory site are unsuitable for drinking purposes due to high salt content. Drinking water is supplied by tanker from Sennar town. Water from the wells is used for general purposes via 13 m high tank (17 000 gallons). Distribution is by galvanised steel pipe.	One well is now disused due to blockage. The foundations of the high level tank have settled but do not require remedial works. A 5 000 gallon steel ground tank is on site awaiting excavation.
Surface Water Drainage	No special provisions are made.	Water ponds after rain in the southeast of the factory yard. Sheet flooding occurs from the south and southeast. Drain-adjacent to factory fence needs to be cleared.
Sewage Disposal	Aqua privies.	Not in use due to misuse. Factory management proposes to replace with pit latrines.
Roads/Access	Gravel road connects main gate to office area. No other surface roads to or within factory site. Sudan Railways sidings.	
Fencing	Plain wire and steel angle posts.	In good condition.
Platforms and Hardstandings	912 m <sup>2</sup> concrete hardstanding in front of factories Nr 1 and 2 mixing rooms. 400 m long loading platform adjacent to railway.	In good condition. Required sand and gravel backfill.
Houses	Adjacent to the factory site there are the following houses owned by SGB :  Senior type           3 Middle type         23 Junior type          35  Constructed in brick with GCI roofing and concrete tile floors. Water-borne sewage with septic tanks and aqua privies.	Houses are in good condition. Some of the staff live in Sennar, e.g. electrical engineer, classifier. They are transported to the factory site by bus. A tanker is required for septic tank emptying. Other buildings in the residential area are mosque, co-operative shop, bakery and rest house.

TABLE 6.3.1

LOCATION : KASSAB FACTORY Nr 1

GINNERY INVENTORY : MACHINERY

System	Method	Make	Type	Year	Serial Nr	Power	Comment
<b>Power Supply</b>	N.E.C. Network Transformers						
<b>Seed Cotton Conveyance From Yard</b>	Manual loading/unloading from tractor drawn trailers		Ford 8 No.				
<b>Conveyance within Ginnery</b>	Manual to 4 feeding points in ground level suction pipes, within gin building mixing room - via 12 canvas valve pneumatic elevators to ground level wing storage areas	Davidson	Scirocco Size 20 (1)		68934	26 KW	Good condition
		Belfast	" " (2)		68935	26 KW	" "
			" " (3)		68936	26 KW	" "
		Platt	N/A (4) Canvas valve droppers		N/A	30 KW	" "
<b>S/C Cleaning</b>	Manual feeding into hopper/feeder	Platt	Lattice 60 No.		N/A		5 Gin stands without feeders others satisfactory condition
<b>S/C Conditioning</b>	Nil						Some light dust and trash extraction from pneumatics.
<b>Gin Stands</b>	Roller - 65 No.	Platt/ Dobson	Model 1 single acting single roller, single stripper		N/A	195 KW	Lint output on Acala only 16kgs per gin hr due mainly to restrictions on seed handling equipment. Many rollers under-sized

<b>Cotton Seed</b> Seed Conveying	Conveying system set in floor below gin stands. Bucket elevator	N/A	Shaker conveyors 5 No.	Satisfactory
	Seed Gribble	Rosedowns	Single drum c/w 1 trash screen and 2 seed screens	Unable to take c/s away quickly enough. Present installation designed for only 40 roller gins. Now unable to handle output from 65 gins especially on Acala.
	Dust Extraction	Rosedowns	Fan	
	Conveyor Saw Gins	Platt	Shaker 40 saw x 8" OD 3 No.	OK Recovered lint manually bagged. Recovered seed re-directed to gribble.
<b>Lint</b> Lint Conveying	Manual loading into single rail mounted truck running along central area between gin stand rows. Manual unloading of truck onto farfara platform.	N/A		Uneven floor levels result in difficult movement of trucks. Unsatisfactory method.
	Manually sprayed	N/A		Poorly applied.

37 KW  
2 KW  
7.5 KW  
11 KW  
4 KW  
11 KW

N/A  
N/A  
N/A  
N/A  
N/A  
N/A

OK  
Recovered lint manually bagged.  
Recovered seed re-directed to gribble.

Uneven floor levels result in difficult movement of trucks.  
Unsatisfactory method.

Poorly applied.

GINNERY INVENTORY : MACHINERY

TABLE 6.3.1 (cont.)

LOCATION : KASSAB FACTORY Nr 1

System	Method	Make	Type	Year	Serial Nr	Power	Comment
Lint Baling	Hydraulic trampler and bale press, rotating double boxes, lint manually	J. Shaw	Hydraulic oil down-packing trampler, 3.1/2" O.D. cylinder x 11'6" stroke. Pump size 4 SH @ 300 lbs/sq.in W.P.	1955		15 KW	Box size 25" x 39" x 12'6" deep Bale weights 200 kgs average (31 lbs/cu.ft - 83 kgs/cu.m.) Spares problem
		J. Shaw	Hydraulic oil up-packing bale press 3 x 7.1/4" OD rams x 11'6" stroke @ 310 tons W.P. Pump size P.12 @ 1 ton/sq.in W.P.			26 KW	Operating satisfactorily although wear and tear evident.
		Hastie	7.1/4" OD x 12" OD Circulating Pumps		N/A	3 KW	OK

Old Name	Site	Plant / Equipment	Year	Capacity / Power	Notes
2/C Drying	Water / Cement	Super 88 air flow x 12" DO covers, 1/4" gaskets	1962	(1) 30 KW (2) 30 KW 15 KW @ 30 KW	Good Condition
2/C Comminuting	MF	DF 176 Dust Fan	1961	30 KW	
2/C Comminuting	MF	400mm (width) x 200mm (depth) x 1/4" gaskets	1961	6 KW 12 KW	Good condition
2/C Comminuting	MF	6" x 12" R.S.S. gaskets	1961	15 KW	Good condition
2/C Comminuting	MF	MF/A	1961	13 KW	Refrigerating to heavy duty condition
2/C Comminuting	MF	DF 176 Dust Fan	1961	30 KW	
2/C Comminuting	MF	60" DO x 30" wide	1961	28 KW	Good condition
2/C Comminuting	MF	1st. Stage V.A. Fan	1961	23 KW	Good condition
2/C Comminuting	MF	1st. Stage V.A. Fan	1961	23 KW	Good condition

LOCATION: KAZAN FACTORY NO 3

1967 213

УВАЖАЕМЫЕ УГОЛОВНИКИ

GINNERY INVENTORY : MACHINERY

TABLE 6.3.2

LOCATION : KASSAB FACTORY Nr 2

System	Method	Make	Type	Year	Serial Nr	Power	Comment
Power Supply	NIL						Direct drive diesel engine removed 1979. Promised installation of mains power transformers and full electrification of ginmery has, to date, not taken place.
Seed Cotton Conveyance from Yard	Manual loading/unloading from tractor drawn trailers.						
Conveyance within Ginmery	Manual feeding into floor level suction pipe, from mixing room at end of building.	Platt/ Lummus	Double DF 176 Fan	1961	N/A	56 KW	Good condition
	Air Separator	"	72" Combined Separator/ vac. wheel "C" type.		L32 1961	12 KW	Good condition
Feeding to Gin stands	Conveyor Distributor	"	16" O.D. screw			7.5 KW	Good condition
	Extractor/feeders	"	Super Thermex, c/w Hydraulic feeders.				Good condition
S/C Conditioning	NIL						
S/C Cleaning	Inclined Cleaner	Platt Lummus	6 cyl. x 72" wide		L32 1961	12 KW	Good condition

Gin Stands	Saw	Platt/ Lummus	Super 88 air blast x 12" OD saws, c/w overhead moting	L32 1962	(1) 30 KW (2) 30 KW (3) 30 KW	Good Condition
Cotton Seed Seed Conveying	Below gin conveying Seed Blower	"	DF 176 Blast Fan		30 KW	"
	Remote receiving hopper	N/A	30 ton capacity c/w 4 bagging spouts (gravity fed)	N/A		Requires building to keep out elements.
Trash Removal Trash conveying	Below gin conveying Pneumatic from Feeders, Inclined Cleaners, Lint Cleaners	Platt/ Lummus	6" OD Screw Double DF 176 Fan	8118	6 KW 12 KW	Good condition
Cotton Lint Lint Conveying	Air Blast Battery Condenser	Platt/ Lummus	60" OD x 40" wide		2KW	Good Condition
Lint Cleaning	Air Stream	"	Jet Stream/V.A. Fan	N/A	23 KW	"
Lint Conditioning	Lint Slide Spray	"				

**GINNERY INVENTORY : MACHINERY**

**LOCATION : KASSAB FACTORY Nr 2**

**TABLE 6.3.2 (cont.)**

System	Method	Make	Type	Year	Serial Nr	Power	Comment
Lint Baling	Mechanical Trampler with Oil	Platt/ Lummus	Kicker paddle feeder				Box size 20" x 41"
	Hydraulic bale press and double rotating boxes. Mechanical lint Feeding		Short Stroke chain and sprocket trampler		Model No. HDP 20414	15 KW	Good Condition
			H188 'B' Type pump unit			45 KW	"
	Door Locks		Hydraulic hand pump				"
	Box Turning - manual						"
Trash Collection	Remote Cyclones						Fair Condition



TABLE 6.3.3

LOCATION: KASSAB FACTORY Nr 3

GINNERY INVENTORY : MACHINERY

System	Method	Make	Type	Year	Serial Nr	Power	Comment
Power Supply	NEC Network Transformers						
Seed Cotton Conveyance from Yard	Manual loading/unloading from tractor drawn trailers	J. Deere	Model 1030				
Conveyance within Ginnery	Manual feeding into under-floor suction pipe, within remote s/c mixing room, using suction fans.	Murray Piritininga	Dual 45/50 Fans (1) (2)	1976	01199022	56 KW 56 KW	Fan casings in very poor condition - trash and dust discharging into atmosphere.
	Feed Control Unit (C.F.M.) consisting of:-	"	3 Cyl. Airline Cleaner	"			Operation satisfactory
		"	96" Air separator	"	01199381		
		"	Upper Vac. Wheel	"	EN 199	22 KW	
		"	Storage Hopper	"	01199333		
		"	Lower Vac. Wheel	"	EN 198		Replaced with fixed speed drive
		Reeves	Variable feed drive	"			
	Conveyor Distributor	Murray Piritininga	16" OD Screw			6 KW	Operation satisfactory
	Overflow Hopper (A.O.F)	"	Automatic Overflow Variable Feed Drive		01199330		
	Overflow Separator	Reeves			N/A	0.75 KW	Replaced with fixed speed drive.
		"	52.3/8" Air Separator C/W Vac. Wheel		01199375		
S/C Conditioning	Humidification, using fans	S.Jackson	Humidaire Unit Push Fan 35/40 Pull Fan 35/40	"	N/A	30 KW	Intact Not used - honeydew No vee belts
				"	01199018	30 KW	Operating - in order to remove trash - ineffective.

S/C Cleaning	Hand Picked s/c cleaners	Murray Piritininga	2 No. 72" x 7 cylinder inclined cleaners 35/40 Trash/Pull. Fan(1) 35/40 Trash/Pull Fan(2)	1976	M-010199241	15 KW 15 KW 30 KW 30 KW	Operation satisfactory - not always in use.
	Gin Feeders	Murray Piritininga Mitchell	3 No. Cotton King Extractors Model CK 2983/1	"	"		Operation satisfactory Manual control only
Gin Stands	Saw	Murray Piritininga	3 No. 142 x 18" OD (1) brush gins (2) (3)	"	01199158	56 KW 56 KW 56 KW	Operation/condition good Auto gin breast throwout removed
Cotton Seed Seed Conveying	Conveyor below gin stands	" " Sutorbilt	12" OD Screw Vacuum Dropper 8 lb/sq.in.seed blower	"	"	7.5 KW 19 KW	Operation satisfactory
		Murray Piritininga	48" OD Cyclone and Vacuum Dropper 24' long conveyor 6 No. double bagging spouts.	1976	N/A	7.5 KW	Operation satisfactory
Trash Removal Trash Conveying from Gin Stands	Screw Conveyor below gins	"	12" OD Screw Vacuum Dropper Trash Fan 35/40	"	01199018	30 KW	Operation satisfactory Also acts as o/flow suction fan.

LOCATION: KAYAB FACTORY #2

TABLE 8.2.3 (cont.)

TABLE 6.3.3 (cont.)

LOCATION: KASSAB FACTORY Nr 3

GINNERY INVENTORY : MACHINERY

System	Method	Make	Type	Year	Serial Nr	Power	Comment	
Cotton Lint Lint Conveying	Saw Brush Draught	Murray Piritininga	40" wide x 68" OD	1976	N/A	2.2 KW	Operation satisfactory - lint backing upon lint slide	
	Battery Condenser	"	29" OD Condenser V.A. Fan	"	N/A	30 KW		
Lint Baling	Tramper Feeder - mechanical	"	Pneumatic pusher Compressor	"	N/A	7.5 KW	Operation erratic	
	Mechanical Tramper Oil Hydraulic bale press	"	Atlas gear & Chain 20" x 40" PCX,2 ram up-packing, standard density, revolving boxes	"	N/A	15 KW	Operation satisfactory Some movement around centre column.	
Lint Cleaning	Press Pump	Abex Denison	Vane & Piston Pumps(1) (2)		N/A	37 KW	All disconnected from gin and main lint flue. Some cannibalisation. Intact	
	Box Turning - mechanical Door locks	Murray Piritininga	Powered chain drive Powered hydraulic	1976	N/A	37 KW		
	Saw Type Cleaners		"	Model 100 - 3 No. (1) (2) (3)	"	"		6 KW
			"	29" OD V.A.Fans (1) (2) (3)	"	N/A		6 KW
			"	Trash Fan 35/40	"	N/A		19 KW
			"		"	"		19 KW
		"		"	"	15 KW		
		"		"	"	15 KW		
		"		"	"	15 KW		
		"		"	"	30 KW		

**Trash Collection**

Condenser	Lint Cleaners	Lint Fly Collection	Murray Pirtitinga	Inline Filters	No. In-line Filters	1976	0.75 KW	Lint fly discharging to atmosphere. No motors or driving sprockets and chains. Wiring disconnected.
		Lint Fly Suction Fan Cyclones	"	35/40 Fan 10 No. 48" OD	(1) (2) (3)	" " "	N/A N/A N/A	No motor or piping. Extremely high level of dust and trash pollution.

TABLE 6.4

LOCATION: KASSAB

GINNERY INVENTORY: POWER SUPPLY

Power supply	HV switchgear	LV switchgear	Distribution transformers	Power factor correction
NEC-11 kV	None	<p><b>Factory Nr 1</b> 415 V combination fuse switchboard with TP &amp; N busbar chamber</p>	<p>Woden, 1968/69 1 x 1 000 kVA, 11 000/433 V</p>	None
None (formerly direct drive with line shaft. Engine now removed)	None	<p><b>Factory Nr 2</b> None</p>	None	None
NEC-11 kV	<p>Driescher, 1977 approx. 11 kV, 630A, 250 MVA fault current rating</p>	<p><b>Factory Nr 3</b> Klockner Moeller, 1977 approx. 415 V, 2 000A</p>	<p>IEO, Breda, 1977 11 000/433 V 1 x 1 000 kVA</p>	<p>6 x 40 kVAR automatic</p>

Универсальный  
Здание

Детали  
Фасад  
Средняя часть  
Общая структура

Этаж  
Этаж  
Этаж  
Этаж

Этаж  
Этаж  
Этаж  
Этаж

Этаж  
Этаж  
Этаж  
Этаж

Этаж  
Этаж  
Этаж  
Этаж

Этаж  
Этаж  
Этаж  
Этаж

Этаж  
Этаж  
Этаж  
Этаж

Этаж  
Этаж  
Этаж  
Этаж

Этаж  
Этаж  
Этаж  
Этаж

Этаж  
Этаж  
Этаж  
Этаж

Этаж  
Этаж  
Этаж  
Этаж

Этаж  
Этаж  
Этаж  
Этаж

Этаж  
Этаж  
Этаж  
Этаж

Этаж  
Этаж  
Этаж  
Этаж

Этаж  
Этаж  
Этаж  
Этаж

Этаж  
Этаж  
Этаж  
Этаж

Этаж  
Этаж  
Этаж  
Этаж

Этаж  
Этаж  
Этаж  
Этаж

Этаж  
Этаж  
Этаж  
Этаж

Этаж  
Этаж  
Этаж  
Этаж

Этаж  
Этаж  
Этаж  
Этаж

Этаж  
Этаж  
Этаж  
Этаж

Этаж  
Этаж  
Этаж  
Этаж

Этаж  
Этаж  
Этаж  
Этаж

Этаж  
Этаж  
Этаж  
Этаж

Этаж  
Этаж  
Этаж  
Этаж

Этаж  
Этаж  
Этаж  
Этаж

Этаж  
Этаж  
Этаж  
Этаж

Этаж  
Этаж  
Этаж  
Этаж

Этаж  
Этаж  
Этаж  
Этаж

Этаж  
Этаж  
Этаж  
Этаж

Этаж  
Этаж  
Этаж  
Этаж

Этаж  
Этаж  
Этаж  
Этаж

Этаж  
Этаж  
Этаж  
Этаж

Этаж  
Этаж  
Этаж  
Этаж

Этаж  
Этаж  
Этаж  
Этаж

ГОСУДИТЕЛИ

СРЕДНЯЯ ЧАСТЬ

Этаж

TABLE 7.1

GINNERY INVENTORY: BUILDINGS

Building	Description	Approximate dimensions L x W x H (m)	Comments
<b>Main Buildings</b> Ginning factory	Structure : steel framed stanchions and trusses Walls : GCI sheeting Roof : GCI sheeting Floor : concrete	72 x 36 x 6.5	In good condition, no remedial works required. Dimensions are overall including mixing room and seed room.
Office staff	Structure : load bearing brickwork Roof : concrete Floor : concrete tiles	20 x 12 x 4	Building has subjected to heave. Considerable cracking has occurred which requires frequent maintenance.
Office manager	Structure : load bearing brickwork Roof : GCI sheeting Floor : Concrete tiles	8 x 4 x 4	In good condition, no remedial works required.
Store	Structure : steel framed Walls : GCI sheeting Roof : GCI sheeting Floor : concrete	20 x 12 x 4.5	In good condition, no remedial works required.
Workshop	Structure : steel framed Walls : GCI cladding Roof : GCI cladding Floor : concrete	8 x 8 x 4.5	In good condition, no remedial works required.
<b>Other Buildings</b> Gate house Latrines Dispensary Pump house Store keepers office Ablution block	Brickwork and GCI roofing	various	In good condition, no remedial works required.

TABLE 7.2

## GINNERY INVENTORY: INFRASTRUCTURE

LOCATION: DUEIM

Facility	Description	Comments
<b>Water Supply</b> (a) Firefighting	Water is abstracted by pump from an irrigation canal and stored in 11 000 gallon circular ground tank. The water is pumped from the ground tank to an 18 m high tank (1 600 gallons) which supplies 24 fire hydrants in the factory yard and the ginnyery sprinkler system.	Firefighting system is adequate.
(b) Domestic and other uses	Municipal supply.	Adequate, no problems reported.
<b>Surface Water Drainage</b>	No special provisions.	No problems reported. Natural drainage takes place in adjacent lower ground.
<b>Sewage Disposal</b>	Bucket latrines.	
<b>Roads/Access</b>	No surface roads to or within the factory.	
<b>Fencing</b>	Plain and barbed wire with steel angle posts.	In good condition.
<b>Platforms and Hardstandings</b>	1 500 m <sup>2</sup> concrete platforms.	In good condition.
<b>Houses</b>	Senior type 1 Middle type 2	Other staff live in private accommodation in Dueim town.
	Constructed in brick with GCI sheeting roofs and concrete tile floors. Sanitation by bucket latrines.	

## GINNERY INVENTORY : MACHINERY

TABLE 7.3

LOCATION : DUEIM

System	Method	Make	Type	Year	Serial Nr	Power	Comment
Power supply	Diesel Generators - Engine	Ruston Diesel	Size 6 Class VCB 600 RPM	1959	422374		All engines and alternators in very good condition, although major overhauls now overdue on Nos. 3 & 4 sets
	Alternator	British Thompson Houston	AGT 102	"	R 228090	156 KVA	
	Engine	Ruston Diesel	Size 6 Class VCB 600 RPM	"	422371		
	Alternator	B.Th.H.	AGT 102	"	R228088	156 KVA	
	Engine	Ruston Diesels	Size 6 Class VCB 600 RPM	"	422372		
	Alternator	B.Th.H.	AGT 102	"	R228089	156 KVA	
	Engine	Ruston Diesels	Size 6 Class VCB	1964	512446		
	Alternator	A.E.I.	AG 36/18	1964	R229661	156 KVA	
	Starting Air Compressors	Ruston	Size 3" x 3.1/2"	1959	42283	5 KW	
		Ruston	Engine driven petrol		49974		
		Ruston	Size 3" x 3.1/2"		418530		

<b>Seed Cotton</b> Conveying From Yard	Contractors truck - manual loading/ off loading	4 in operation Massey Ferguson	12 sacks per lotry
Conveyance within Ginnery	Manual feeding into any of 12 points within mixing room attached to ginnery via 8 pneumatic canvas valve elevators to central area between gin lines	Davidson Belfast	Good condition
S/C Cleaning	Manual feeding into auto feeder hoppers	Platt	Condition/operation good
S/C Conditioning	Nil machinery		Light dust and trash removed by pneumatic systems.
Gin Stands	Roller - 48 No.	Platt	86 lbs. (39 kgs) lint/gin hr. on Acala variety 111 lbs. (50 kgs) lint/gin hr on Barakat variety.
Cotton Seed Seed Conveying	Pneumatic from below gin stands, to cyclones collectors and conveyors and elevators	Davidson Belfast "	(vacuum wheels)
	Gribble	Rosedowns Davidson	Condition/operation good
			Good

TABLE 7.3 (cont.)

GINNERY INVENTORY : MACHINERY

LOCATION : DUEIM

System	Method	Make	Type	Year	Serial Nr	Power	Comment
<b>Scarto</b> Scarto Handling	Conveyors Saw gin lint recovery → manual lint recovery. Recovered c/s re-directed to gribble.	Platt	Screw conveyor 9" OD 40 x 8" OD Saw brush			4 KW	Good Fair condition
<b>Cotton Lint</b> Lint conveying	Manual loading into 2 trucks along outer wings of gin lines. Manual unloading onto Farfara platform.	N/A					Very labour intensive
<b>Lint Conditioning</b>	Manual spraying	N/A					Poorly applied
<b>LintBaling</b>	Hydraulic tramper and bale press, rotating double boxes, lint manually loaded	J.Shaw	Hydraulic oil down- packing tramper, 3.1/2" OD ram x 11'6" stroke @ 330 lbs/sq.in W.P.				Operation and condition good Box size 25" x 39" x 12'6" 420 lb (190 kg)av.bale wt. 27 lbs cu.ft. (432 kgs/cu.m.) Standard density. 6 ties per bale.
	Tramper pump	D.Brown	Pump size 4SH Roloid Gear Pump			15 KW	
	Press Pump	Hastie	Hydraulic oil up-packing bale press 3 x 71/4" OD rams x 11'6" stroke @ 310 ton W.P.				Operation/condition good spares availability a problem.
	Intensifier	J. Shaw	Pump size P12 WP 1 ton/sq.in. 12" to 7.1/4" OD x 5'0" stroke		Order No. 4349	26 KW	
	Hydraulic oil cleaning by centrifuge.	De Laval	4024X-G		2636238	1 KW	Condition/operation good

**Workshops** Maintenance 1959 N/A Good well equipped workshop. Adequate.

40 KW

Centre Lathe  
3000 x 250 swing  
welding equipment gas  
and electric. Pillar drill  
machine  
Grinding machine  
Forge  
Knife sharpening m/c.

**Water Supply** Borehole - high level tank

**Fire Fighting**

Dennis  
Petrol engine  
Centrifugal water pump.

1959 N/A N/A

ГЛАВНОЕ ДРЕВЯ

ЛВНГЕ 334

TABLE 7.3 (cont.)

LOCATION: DUEIM

TABLE 7.4

LOCATION: DUEIM

**GINNERY INVENTORY: POWER SUPPLY**

Power supply HV switchgear LV switchgear Distribution transformers Power factor correction

Private generation:  
 4 x 156.2 kVA  
 415 V, 0.8 pf  
 600 rpm  
 (3 x BTH  
 1 x AEI)  
 1958 approx.

415 V, 800A, BTH, type V,  
 Class AJ31 with 415 V  
 combination fuse switchboard  
 with TP & N busbar off main  
 busbar

System	Equipment	Year	Capacity	Power	Comments
Private generation	4 x 156.2 kVA, 415 V, 0.8 pf, 600 rpm (3 x BTH, 1 x AEI)				
Power supply	415 V, 800A, BTH, type V, Class AJ31 with 415 V combination fuse switchboard with TP & N busbar off main busbar				
Distribution transformers	11 kV / 415 V, 15 kVA				
Power factor correction	Capacitor bank				



TABLE 8.1

LOCATION: KOSTI

## GINNERY INVENTORY: BUILDINGS

Building	Description	Approximate dimensions L x W x H (m)	Comments
<b>Main Buildings</b> Ginning factory	Structure : steel framed stanchions and trusses Walls : GCI sheeting Roof : GCI sheeting Floor : concrete tiles	85 x 16 x 7	Generally in good condition (some minor upheaval in mixing room floors). No remedial works required.
Office staff	Structure : concrete frame Walls : brick Roof : concrete Floor : concrete	35 x 16 x 4	In good condition, no remedial works required.
Stores	Structure : steel framed stanchion and trusses Walls : GCI sheeting Roof : GCI sheeting Floor : GCI sheeting	30 x 16 x 4	In good condition, no remedial works required.
Workshop	Structure : steel framed Walls : GCI sheeting Roof : GCI sheeting Floor : concrete	14 x 8 x 5	In good condition, no remedial works required.
<b>Other Buildings</b> Latrines Showers Gate houses Contractor's office Ablution block	Brickwork and GCI sheeting	various	In good condition, no remedial works required.

TABLE 8.2

## GINNERY INVENTORY:INFRASTRUCTURE

LOCATION:KOSTI

Facility	Description	Comments
<b>Water Supply</b>		
(a) Firefighting	From municipal supply connected to two ground tanks (400 gallons each). Water pumped by tenders and hoses for yard firefighting. Fire extinguishers are provided in factory.	No hydrants in factory yard.
(b) Domestic and other uses	From municipal supply. 60 m deep well in factory has been abandoned due to high salt content.	Pressure is low and water tends to be turbid.
<b>Surface Water Drainage</b>	No special provisions.	No problems reported. Water is naturally drained to adjacent lower ground.
<b>Sewage Disposal</b>	Water privies and pit latrines.	
<b>Roads/Access</b>	No surfaced roads within factory site. Sudan Railways siding. Factory is adjacent to main town road.	
<b>Fencing</b>	Plain wire and steel angle posts.	In good condition, no remedial works required.
<b>Platforms and Hardstandings</b>	2 200 m <sup>2</sup> concrete platform around factory. 750 m <sup>2</sup> concrete platform in front of store.	In good condition, no remedial works required.
<b>Houses</b>	1 Nr senior staff house occupied by manager.	Factory rents 4 houses for LS 3 910/year and pays housing allowance of 15% basic salary to 4 other senior staff.

## GINNERY INVENTORY : MACHINERY

TABLE 8.3

LOCATION : KOSTI

System	Method	Make	Type	Year	Serial Nr	Power	Comment
Power Supply	White Nile Grid Transformers	Elta Poland	Oil Fitted	1978	160110/1978	750 KVA	Operational
	Diesel Generators - 2 No.	Ruston Diesel	Size 7, Class VEB 500 RPM	1955	418758	306 KVA	Good Condition
Lighting Plant	Air Starting Compressors	Electric Construction Co.(Wolves)	415v. Alternator	1955	256859	306 KVA	"
		Ruston Diesel	Size 7 Class VEB 500 RPM	1955	418757		"
Seed Cotton Conveying from Yard Manual loading/unloading	Air Starting Compressors	Electric Construction Co. (Wolves)	415V Alternator	1955	256859	306 KVA	"
		Ruston Diesel	4YC 1500 RPM		418207		"
Seed Cotton Conveying from Yard Manual loading/unloading	Air Starting Compressors	Crompton Parkinson	415V Alternator		F0102 A218	31 KVA	"
		Ruston	Twin 3" x 31/2"		408785/6	3 KW	"

Conveyance within ginnery	Manual to 12 feeding points within 2 mixing areas either side of ginnery - via 8 canvas valve pneumatic elevators	Davidson (Belfast) Terzakian (Egypt)	Scirroco Class D No.24 Suction Fan Suction Fan	1955	Fan No.86640 26 KW Works No.572996 N/A 38 KW	Condition good Replacement for former Davidson fan.
S/C Cleaning	Manual feeding to auto feed hoppers Nil machinery	Platts	Lattice type feeder	1955		Condition/operation good  Light dust and trash removed by pneumatics. Good trash removal at gin feeders.
S/C Conditioning	Gin hall humidifiers	Mather/Platt	Compressed air/water system			Defunct
Gin Stands	Roller - 48 No.	Platts	Model 2 S.A.S.R. c/w Barakat type double strippers.	1955	144 KW	46 - 52 kgs lint per gin stand hour on Barakat
Cotton Seed C/S Conveying	Mechanical Conveyors Bucket Elevators Seed Gribble 2 No.	" N/A N/A	6" OD Screw conveyors Shaker conveyors 3 c/s bagging spouts	1955	12 KW 2 KW 4 KW 15 KW	No trash removal screens fitted
Scatto Scatto Handling	Conveyors - recovered seed Conveyors - Scatto Saw Gins - manual Lint Collection	N/A Platt	Shaker Conveyors Screw Conveyor 40 saw x 8" OD brush gins.		2 KW 4 KW 8 KW	Fair condition

TABLE 8.3 (cont.)

LOCATION: KOSTI

GINNERY INVENTORY : MACHINERY

System	Method	Make	Type	Year	Serial Nr	Power	Comment
Cotton Lint Lint Conveying	Manual loading into tyred trucks - 1 per line of 24 gins. Manual unloading onto farfata platform.	N/A			N/A		Uneven floor - some effort needed to push trucks.
Lint conditioning	Manual application						Poorly applied.
Lint Baling	Hydraulic tramper and bale press, rotating double boxes manual loading of lint	J. Shaw	Hydraulic oil down packing tramper - 31/2" OD ram x 11'6" stroke -WP 300 lbs/sq.ins.		Order No. 3580	15 KW	Box Size 25" x 39" x 12'6" 410 lb (186 kg) av.wt. bale. 29 lbs/cu.ft.(77 kg/cu.m.) Standard density 6 Bale Straps.
Water Supply	Intensifier  Town Supply	J. Shaw	Hydraulic Oil up-packing press 310 ton 3 x 71/4" rams - 11'6" stroke  12" to 71/4" OD rams x 5'0" stroke.	1955	"	42 KW	Inadequate size supply pipe. No reservoir.
Fire Fighting	Mobile fire tender  Portable Fire Pump - draws from engine cooling tank	Land Rover  Coventry Climax	Rear mounted power take off to Godiva pump. c/w 2000 litre water tank.  Handstart petrol engine 4 cyl.		FN 40017 S 7822		Operational

210 litre barrels in s/c storage area.

Workshops

Adequate - good supply hand tools etc.

602 TFW  
7822

Centrigugal - 2 branch discharge

Godiva Pump

Centre Lathe  
500 mm swing x 2000 bed.

Swedish

Pillar drill 3/4" cap. Welding Machine.

N/A  
Hobart

Το 2ο εμβόλο\*  
φ 14 ρομπά ούτ ιατρίο ρομπά\*  
1πασ εμπίστρονσά μετρί 15  
μετρί φ12 Λ σολμπίροισι  
Β11Μ\* ΓΑΒΕ Β' Σ1888 ΥΤ11  
φ12 Λ' 3000 εμπίστρονσά

Τ x 320 ΚΑΛΥ\* Τ1 000ΛΥ22 Λ  
Ε119 (βελισιού) Τ028

ανθράκ  
βόμβη

ΗΛ εμπίστρονσά

ΓΑ εμπίστρονσά

σολμπίροισι  
βόμβη 150φ14

Σ1888ΚΑ ΙΜΕΙΛΟΚΑ ΒΟΜΒΗ Σ1888ΓΑ

ΓΟΣΥΛΙΟΜΡ ΚΟ211

1ΛΒ1ΓΕ Β' 4

TABLE 8.3 (cont.)

GINNERY MACHINERY

LOCATION: KOSTI

TABLE 8.4

GINNERY INVENTORY: POWER SUPPLY

LOCATION: KOSTI

Power supply HV switchgear

LV switchgear

Distribution transformers

Power factor correction

NEC-11 kV  
Private generation:  
2 x 306.25 kVA  
415 V, 0.8 pf  
ECCo, 500 rpm.

415 V, 800A switchboard  
BTH, type V, Class AJ31  
with 415 V combination  
fuse switchboard with TP  
& N busbar off main busbar,  
1958 approx.

Elta (Poland), 1978  
1 x 750 kVA, 11 000/433 V

Auxiliary generator (off-season lighting of workshop):  
1 x 31.26 kVA, 415 V, 1 500 rpm  
Crompton Parkinson  
1958 approx.

Insufficient data supply sheet  
No records.  
100% etc.  
1958 approx. - 100% energy used  
Operational

FN 40017  
40017  
40017  
40017

Handwritten record engine & generator  
Crompton Parkinson - 5 phase

510 litre pump in a/c storage case  
Portable Fire Pump - drive from engine cooling tank



## GINNERY INVENTORY:BUILDINGS

TABLE 9.1

LOCATION:RABAK

Building	Description	Approximate dimensions L x W x H (m)	Comments
<b>Main Buildings</b> Ginning factory	Structure : steel framed portal Walls : concrete blockwork to 3 m and glass windows above Roof : asbestos cement sheeting Floor : concrete	144 x 32 x 8	In good condition, no remedial works required.
<b>Stores</b> (3 Nr)	Structure : steel framed Walls : GCI sheeting Roof : GCI sheeting Floor : concrete	25 x 10 x 4 (1 Nr) 20 x 10 x 4 (1 Nr) 13 x 9 x 4 (1 Nr)	In good condition, no remedial works required.
<b>Workshop</b>	Structure : steel framed Walls : GCI sheeting Roof : GCI sheeting Floor : concrete	30 x 12 x 4	In good condition, no remedial works required.
<b>Office</b> (2 Nr)	Structure : load bearing brickwork Roof : GCI sheeting Floor : concrete tiles	25 x 11 x 4 (1 Nr) 17 x 8 x 4 (1 Nr)	Mainly occupied by agricultural staff. In good condition, no remedial works required.
<b>Other Buildings</b> Mosque Firefighting office Latrines Gate room Supervisor's office Electrical substation Club	Brickwalls and GCI sheeting	various	In good condition, no remedial works required.

TABLE 9.2

## GINNERY INVENTORY:INFRASTRUCTURE

LOCATION:RABAK

Facility	Description	Comments						
<b>Water Supply</b>								
(a) Firefighting	From same sources as domestic supply. Water flows from ground tanks (see below) to 7 Nr (2 x 1 m) firefighting pits to which fire hydrants are connected. Fire hydrants supply by electric pump from pit. Factory sprinkler system fed directly from ground tank.	Only 3 hydrants are working and sprinkler pressurising system is not functional. High level tank required to feed hydrants and sprinkler system.						
(b) Domestic and other uses	From municipal supply (1½" connection). Municipal supply frequently cut and alternative supply provided by direct pumping from White Nile. Ground tank (140 000 gallons) and 12 m high tank (1 000 gallons).	No water treatment given to water pumped from river.						
<b>Surface Water Drainage</b>	No special provision.	No problems reported. Water drains naturally to adjacent lower ground.						
<b>Sewage Disposal</b>	Pit latrines							
<b>Roads/Access</b>	No surface roads to or within factory site. Sudan Railways sidings.	Not in use, require reconstruction.						
<b>Fencing</b>	Barbed and plain wire and steel angle posts.	In good condition.						
<b>Platforms and Hardstandings</b>	960 m <sup>2</sup> concrete platforms adjacent to factory. 5 500 m <sup>2</sup> hard-standing in two areas formed by 0.7 high wall and sand and gravel infill.	In good condition.						
<b>Houses</b>	<table border="1"> <tr> <td>Senior staff houses</td> <td>5</td> </tr> <tr> <td>Middle staff houses</td> <td>14</td> </tr> <tr> <td>Junior staff houses</td> <td>23</td> </tr> </table> <p>Constructed in brick with GCI sheeting roofs, concrete tiles and brick floors. Sanitation by aqua privies and pit latrines.</p>	Senior staff houses	5	Middle staff houses	14	Junior staff houses	23	All houses occupied by ginnery staff except 2 senior staff houses. In reasonable condition, maintenance required. A dispensary, mosque, etc. are provided in the residential area.
Senior staff houses	5							
Middle staff houses	14							
Junior staff houses	23							

## GINNERY INVENTORY : MACHINERY

TABLE 9.3

LOCATION : RABAK

System	Method	Make	Type	Year	Serial Nr	Power	Comment
Power Supply	White Nile Grid					11000 V	
	2 No. Transformers	Woden UK	Oil filled	(1) 1967	92261/6	500 KVA	
		"	" "	(2)	9004/55	500 KVA	
	Stand-by Diesel Generators	Bohn u Kahler Kiel F.R.G.	6cyl. Diesel Model KR 185	1954	14620		Condition/operation good Used regularly because of frequent power failures. Spares still available.
	Alternator	A.E.G.	DGS. 160/10	1954	FSL 4451/1561	112 KW	" "
	-Starting compressor - air	Wilhelm Poppe-Kiel	WP 3302	1961	32192	3 KW	" "
	Stand-by Diesel Generator	Bohn u Kohler	6 cyl. diesel Model KR 1285	1954	15265		" "
	Kiel FRG						
	Alternator	A.E.G.	DG 122/12	1954	455129	270 KW	" "
	Starting Compressor - air	Wilhelm Poppe	WP 2338	1958	13558	2.2 KW	" "
Seed Cotton	Manual, loading/unloading using contractors tractor/trailers		10 bags s/c per trailer				In good condition, no spare tractors required.

Conveyance within Ginnery	Manual - sacks opened and s/c piled along outer length of gin hall.					Indisciplined labour causing erratic feeding.
	Manual feeding to gin stands					Erratic. No feed hoppers.
S/C Conditioning	Overhead water sprays in gin hall	N/A	N/A			Not in use. Some hand spraying Poorly applied.
Gin Stands	Roller - 100 No. East and West wings each with 2 lines of 25 gins (50 per wing)	Unknown supplied by Alfred C. Toepfer.	Single roller, S.A. with double stripper	1954	350 KW	Producing 40 kgs lint/hr on Barakat. 29 kgs/hr on Acala.
Cotton Seed						
Seed Conveying	Mechanical conveyors in basement	"	Shaker conveyors	"	52 KW	Condition/operation good
	Bucket Elevators	"	4 No.		9 KW	"
	Seed Gribbles	"	Double drum - 2 No.		5 KW	No trash removal. 4 bagging spouts.
Scarto						
Scarto handling	Scarto conveyors	N/A	Shaker conveyors		6 KW	
	Lint recovery	N/A	80 saw x 8" OD delintlers		20 KW	Very poor condition
	Seed recovery		4 No.		6 KW	
			Shaker conveyors			

TABLE 9.3 (cont.)

LOCATION : RABAK

GINNERY INVENTORY : MACHINERY

System	Method	Make	Type	Year	Serial Nr	Power	Comment
Cotton Lint Lint Conveying	Manual loading into 2 rail mounted trucks running between gin stands.						
	Manual unloading onto Farfara platforms.						
	Manual Spraying						Poorly applied
Lint Conditioning	Hydraulic tramper and bale press, rotating double boxes, lint manually loaded	( Heller	Hydraulic down-packing tramper	1973	N/A	11 KW	Condition/operation satisfactory
		( Lindemann	Single ram - 250 mm O.D. up-packing bale press	1954			Condition/operation good
		( Lindemann	Press pump - Polos IV	1954	Works No. 3307/1 Komm No. 521203	14 KW	Condition/operation good.
Lint Baling	Manual, loading/unloading using	( Heller	Hydraulic down-packing tramper.	1973			Condition/operation good
		( Lindemann	Single ram - 250 mm O.D. up-packing bale press	1954			"
		( Lindemann	Press pump - Polos IV	1954	Works NO. 3307/3 Komm No. 521250		

Water Supply	Town supply	River supply - by pumps	N/A	N/A
	River supply - by pumps			
	Ground Tank	20m x 10m x 3m 600,000 litres		
	Overhead Tank	5000 litres		
<b>Fire Fighting</b>	Pressurised Yard Hydrants and Factory Sprinklers	3 cyl. diesel - wick ignition - hand start. Model KR 10D	1954	14848
	Mobile fire pump - drawing from ground tank.	Dennis		Chassis 7259 T03 Eng.No. 159531 E 189 Pump No. 7911 PF1
	Fire Tender	Pyrene on Morris chassis	N/A	Eng. 40K/SC11A 443661 Vehicle No. 830WF/321288 Spec Ref. M/2098/R/13801
<b>Workshops</b>	Maintenance			Well equipped workshop - machinery old, but serviceable

TABLE 9.4

GINNERY INVENTORY: POWER SUPPLY

LOCATION: RABAK

Power supply	HV switchgear	LV switchgear	Distribution transformers	Power factor correction
<p>NEC-11kV</p> <p>Private generation: 1 x 140 kVa, AEG</p> <p>600 rpm</p> <p>1 x 270 kW, AEG</p> <p>500 rpm</p> <p>1954 approx.</p>	<p>Brush VSI</p> <p>11 kV indoor ring main</p> <p>(NEC owned)</p>	<p>415 V switchboard, open back, manufacture unknown probably 1954</p> <p>1 600 A</p>	<p>Woden 1967</p> <p>2 x 500 kVA, 11 000/433 V</p> <p>(NEC owned)</p>	-

TABLE 10.2

GENERAL INVENTORY OF INFRASTRUCTURE

Category	Description	Location	Comments
Water supply	Water flows by gravity from fire canal to ground tank (50,000 gallons) from which it is lifted to 2 hr 24 in high. Connections to buildings and one feeder 120 fire hydrants in factory yard are 1800 mm PVC conduits. The two tanks are fed by electric pumps. A water pump is provided by diesel pumps. Three pumps are provided for each building block.	Various	Some breakages of PVC pipes have occurred. Some strengthening of floor slabs for unloading water tanks required.
Electricity	Uniform electricity supply. Distribution by galvanized steel pipe. Connections: 1 GCI apartment blocks; 2 in multiple GCI apartment buildings; 1 in multiple blocks.	82 x 12 x 2	No problems reported.
Gas	1000 4 concrete pipes, 1000 1 concrete pipes, 1000 2 in multiple GCI apartment buildings; 1 in multiple blocks.	100 x 40 x 1	Problems reported.
Drainage	1000 4 concrete pipes, 1000 1 concrete pipes, 1000 2 in multiple GCI apartment buildings; 1 in multiple blocks.	100 x 40 x 1	Problems reported.
Structures	Construction of brickwork and concrete. Connections: 1 GCI apartment blocks; 2 in multiple GCI apartment buildings; 1 in multiple blocks.	100 x 40 x 1	Problems reported.
Water supply	Water flows by gravity from fire canal to ground tank (50,000 gallons) from which it is lifted to 2 hr 24 in high. Connections to buildings and one feeder 120 fire hydrants in factory yard are 1800 mm PVC conduits. The two tanks are fed by electric pumps. A water pump is provided by diesel pumps. Three pumps are provided for each building block.	82 x 12 x 2	No problems reported.
Electricity	Uniform electricity supply. Distribution by galvanized steel pipe. Connections: 1 GCI apartment blocks; 2 in multiple GCI apartment buildings; 1 in multiple blocks.	100 x 40 x 1	Problems reported.
Gas	1000 4 concrete pipes, 1000 1 concrete pipes, 1000 2 in multiple GCI apartment buildings; 1 in multiple blocks.	100 x 40 x 1	Problems reported.
Drainage	1000 4 concrete pipes, 1000 1 concrete pipes, 1000 2 in multiple GCI apartment buildings; 1 in multiple blocks.	100 x 40 x 1	Problems reported.
Structures	Construction of brickwork and concrete. Connections: 1 GCI apartment blocks; 2 in multiple GCI apartment buildings; 1 in multiple blocks.	100 x 40 x 1	Problems reported.
Water supply	Water flows by gravity from fire canal to ground tank (50,000 gallons) from which it is lifted to 2 hr 24 in high. Connections to buildings and one feeder 120 fire hydrants in factory yard are 1800 mm PVC conduits. The two tanks are fed by electric pumps. A water pump is provided by diesel pumps. Three pumps are provided for each building block.	82 x 12 x 2	No problems reported.
Electricity	Uniform electricity supply. Distribution by galvanized steel pipe. Connections: 1 GCI apartment blocks; 2 in multiple GCI apartment buildings; 1 in multiple blocks.	100 x 40 x 1	Problems reported.
Gas	1000 4 concrete pipes, 1000 1 concrete pipes, 1000 2 in multiple GCI apartment buildings; 1 in multiple blocks.	100 x 40 x 1	Problems reported.
Drainage	1000 4 concrete pipes, 1000 1 concrete pipes, 1000 2 in multiple GCI apartment buildings; 1 in multiple blocks.	100 x 40 x 1	Problems reported.
Structures	Construction of brickwork and concrete. Connections: 1 GCI apartment blocks; 2 in multiple GCI apartment buildings; 1 in multiple blocks.	100 x 40 x 1	Problems reported.

LOCATION: FAU

GENERAL INVENTORY OF INFRASTRUCTURE

TABLE 10.1

Category	Description	Location	Comments
Water supply	Water flows by gravity from fire canal to ground tank (50,000 gallons) from which it is lifted to 2 hr 24 in high. Connections to buildings and one feeder 120 fire hydrants in factory yard are 1800 mm PVC conduits. The two tanks are fed by electric pumps. A water pump is provided by diesel pumps. Three pumps are provided for each building block.	Various	Some breakages of PVC pipes have occurred. Some strengthening of floor slabs for unloading water tanks required.
Electricity	Uniform electricity supply. Distribution by galvanized steel pipe. Connections: 1 GCI apartment blocks; 2 in multiple GCI apartment buildings; 1 in multiple blocks.	82 x 12 x 2	No problems reported.
Gas	1000 4 concrete pipes, 1000 1 concrete pipes, 1000 2 in multiple GCI apartment buildings; 1 in multiple blocks.	100 x 40 x 1	Problems reported.
Drainage	1000 4 concrete pipes, 1000 1 concrete pipes, 1000 2 in multiple GCI apartment buildings; 1 in multiple blocks.	100 x 40 x 1	Problems reported.
Structures	Construction of brickwork and concrete. Connections: 1 GCI apartment blocks; 2 in multiple GCI apartment buildings; 1 in multiple blocks.	100 x 40 x 1	Problems reported.
Water supply	Water flows by gravity from fire canal to ground tank (50,000 gallons) from which it is lifted to 2 hr 24 in high. Connections to buildings and one feeder 120 fire hydrants in factory yard are 1800 mm PVC conduits. The two tanks are fed by electric pumps. A water pump is provided by diesel pumps. Three pumps are provided for each building block.	82 x 12 x 2	No problems reported.
Electricity	Uniform electricity supply. Distribution by galvanized steel pipe. Connections: 1 GCI apartment blocks; 2 in multiple GCI apartment buildings; 1 in multiple blocks.	100 x 40 x 1	Problems reported.
Gas	1000 4 concrete pipes, 1000 1 concrete pipes, 1000 2 in multiple GCI apartment buildings; 1 in multiple blocks.	100 x 40 x 1	Problems reported.
Drainage	1000 4 concrete pipes, 1000 1 concrete pipes, 1000 2 in multiple GCI apartment buildings; 1 in multiple blocks.	100 x 40 x 1	Problems reported.
Structures	Construction of brickwork and concrete. Connections: 1 GCI apartment blocks; 2 in multiple GCI apartment buildings; 1 in multiple blocks.	100 x 40 x 1	Problems reported.

LOCATION: FAU

## GINNERY INVENTORY:BUILDINGS

TABLE 10.1

LOCATION:FAU

Building	Description	Approximate dimensions L x W x H (m)	Comments
<b>Main Buildings</b> Ginning factories 4 Nr	Structure : steel framed portal Walls : 3 m brickwork, GCI sheeting Roof : GCI sheet Floor : concrete	55 x 15 x 6.5	Some heave of floor slabs has taken place, structures are sound and no remedial works are required except to re-build internal brick built supervisors room (5 x 2 m) due to cracking damage.
Seed rooms (4 Nr)	Construction same as factories	18 x 10 x 6.5	Some heave of floor slabs but no remedial works required.
Mixing rooms (4 Nr)	Construction same as factories	24 x 15 x 6.5	Some heave of floor slabs but no remedial works required.
Power rooms (4 Nr)	Construction same as factories	15 x 8.5 x 6.5	Some heave of floor slabs but no remedial works required.
Delinting plant	Construction same as factories	42 x 17.5 x 6.5	Considerable heave of floor slabs and machine foundations.
Offices 2 Nr	Structure : load bearing brick wall Roof : concrete Floor : concrete tiles	25 x 15 x 4 (1 Nr) 18 x 8 x 4 (1 Nr)	In reasonable condition, some maintenance to mend cracks required.
Main stores 4 Nr	Structure : steel framed portal Walls : 3 m brickwork, GCI sheeting Roof : GCI sheeting Floor : concrete	100 x 40 x 7	In good condition, no remedial works required. Stores are also used by Rahad Corporation for storage of agricultural inputs, etc.
Spare part store	Structure : steel framed portal Walls : 2 m brickwork, GCI sheeting Roof : GCI sheeting Floor : concrete	65 x 15 x 5	In good condition, no remedial works required.
Workshop	Construction same as spare part store	25 x 15 x 5	Some settlement of floor slabs but no remedial works required.
<b>Other Buildings</b> Fire fighting office Dispensary Cotton classifiers office Latrines Guard room Pump houses Car shed	Brickwork and GCI sheeting	various	In reasonable condition.

TABLE 10.2

GINNERY INVENTORY:INFRASTRUCTURE

LOCATION:F AU

Facility	Description	Comments
Water Supply (a) Firefighting	Water flows by gravity from fire canal to ground tank (80 000 gallons) from which it is lifted to 2 Nr 24 m high tanks (each 128 000 gallons). One tank feeds sprinkler systems in buildings and one feeds 120 fire hydrants in factory yard via 150 mm PVC pipes. The two tanks are fed by electric pumps. Booster electric and standby diesel pumps are provided to boost pressure in the hydrant/sprinkler systems. These pumps have never been commissioned.	Some breakages of PVC pipes have occurred.
(b) Domestic and other uses	From municipal supply. Distribution by galvanised steel pipe system.	No problems reported.
Surface Water Drainage	No special provisions made.	Drainage could be improved by the provision of sumps to facilitate pumping of excess water to fire canal.
Sewage Disposal	Aqua privies.	In good condition.
Roads/Access	Black top surfaced road to factory gate from Wad Medani/Port Sudan road. Gravel surface road runs east-west from gate along site. Black top road from south gate to stores.	In good condition. Fence has been extended 250 m to south and 300 m to east to increase area of site.
Fencing	Plain wire with steel angle posts.	
Platforms and Hardstandings	None	
Houses	Rahad Corporation owns :  Senior staff houses 47 Middle staff houses 33 Junior staff houses 171	Only 33 of the houses are occupied by ginnery staff.

in Fau town. Construction is of brickwork with GCI sheeting roofs. Water-borne sewage with septic tanks and aqua privies.

TABLE 10.3.1

LOCATION: FAU FACTORY Nr 1

GINNERY INVENTORY : MACHINERY

System	Method	Make	Type	Year	Serial Nr	Power	Comment
Power Supply	N.E.C. Network Transformers.						
Seed Cotton Conveyance from Yard	Manual loading/unloading from tractor drawn trailers	J. Deere	Model 1030				
Conveyance within Ginnery	Manual feeding into under-floor suction pipe, within remote s/c mixing room, using suction fans	Murray	Dual 45/50 Fans (1)	1977	10693601	56 KW	Fan condition/operation satisfactory.
		Piritininga	(2)	1977	"	56 KW	Piping badly holed allowing dust to discharge into ginnery.
Conveyance within Ginnery	Feed Control Unit (C.F.M.) consisting of:-	"	3 cyl. Airline Cleaner	1977	N/A )		
		"	96" Air Separator	"	N/A )		
		"	Upper Vac. Wheel	"	10671601)	22 KW	
		"	Storage Hopper	"	N/A )		
		"	Lower Va.c. Wheel	"	10671601)		
	Reeves	Variable Feed Drive	"	N/A	0.75 KW	Removed - straight through suction Replaced with locally made fixed speed drive.	
Conveyor Distributor		Murray Piritininga	16" O.D. Screw	"	N/A	6 KW	
Overflow Hopper (A.O.F.)		"	Automatic Overflow Variable Feed Drive	"	10568010	0.75 KW	Replaced with locally made fixed speed drive
Overflow Separator		Murray Piritininga	52.3/8" Air Separator C1/2W Vac. Wheel	"	10682501		Drive from inclined cleaner Condition/operation satisfactory



TABLE 10.3.1 (cont.)

LOCATION: FAU FACTORY Nr 1

GINNERY INVENTORY : MACHINERY

System	Method	Make	Type	Year	Serial Nr	Power	Comment
Cotton Seed Seed Conveying	Conveyor below gin stands	Murray	12" O.D. Screw	1976	N/A )	7.5 KW	Operation/condition satisfactory
		Piritininga	Vacuum Dropper	"	N/A )		"
		Sutorbilt	8 lb/sq.in.seed blower	"	N/A	19 KW	"
		Murray	48" O.D.Cyclone and	"	N/A		"
		Piritininga	Vacuum Dropper	"	N/A )	7.5 KW	Removed
		"	24' long conveyor	"	N/A )		Shortened to 12'
Trash Removal Trash Conveying from Gin Stands	Screw Conveyor below gins	"	6 No. double bagging spouts.	"	N/A		Reduced to 2 x doubles
		"	12" OD Screw	"	N/A		Removed and replaced by suction system from trash fan.
		"	Vacuum Dropper	"	N/A		Also acts as humidaire pull fan.
		"	Trash Fan 35/40	"	10860301	30 KW	Casing holed, discharging trash to gin room.
Cotton Lint Lint Conveying	Saw Brush draught Battery Condenser	Murray	40" wide x 68"OD	1976	N/A		Some damage to rubber flashings from fires. Operating satisfactorily.
		Piritininga	29" OD Condenser	"	N/A	2.2 KW	
		"	V.A. Fan	"	N/A	30 KW	
Tramper Feeder - Mechanical		"	Pneumatic pusher	"	N/A		Operation satisfactory.
		"	Compressor	"	N/A		"

Lint Baling	Mechanical Trampler	Murray	Atlas gear & chain	1976	N/A	15 KW	Operating satisfactory. Press -
	Oil Hydraulic bale press	Piritininga	20" x 40" PCX, 2 Ram up-packing, standard density, revolving boxes	"	N/A		4 Outer tie rods broken this season. Excessive movement of press boxes on centre column. Complete overhaul urgently reqd.
	Press Pump	Abex	Vane & Piston Pumps(1)	"	N/A	37 KW	Operating satisfactory
	Box turning - mechanical	Denison	(2) Powered chain drive	"	N/A	37 KW	Operating satisfactory
Lint Cleaning	Door locks	Murray	Powered hydraulic	"	N/A	6 KW	Only 2 locks per door in place - centre lock missing. Upper locks giving under pressure resulting in wedge shaped bale.
	Saw type cleaners	"	Model 100-3 No. (1)	"	1071201	19 KW	Out of use - cannibalised to service gin stands
		"	(2)	"	10683601	19 KW	All motors removed
		"	(3)	"	N/A	19 KW	
Trash Collection	Lint fly collection	Murray	29" OD V.A. Fans (1)	"	N/A	15 KW	All inline filters dismantled
	" " "	Piritininga	(2)	"	N/A	0.75 KW	V.A. fans discharging to atmosphere.
	" " "	"	(3)	"	N/A	0.75 KW	
	Lint fly suction fan	Murray	Trash Fan 35/40	"	N/A	30 KW	Fan removed.
Lint Cleaners	Cyclones	Piritininga	3 No. Inline Filters (1)	1976	N/A	0.75 KW	Dust and trash escaping to atmosphere. Cyclones and piping holed.
		"	(2)	"	N/A	0.75 KW	
		"	(3)	"	N/A	0.75 KW	

TABLE 10.3.2

LOCATION: FAU FACTORY Nr 2

## GINNERY INVENTORY : MACHINERY

System	Method	Make	Type	Year	Serial Nr	Power	Comment
Power Supply	NEC Network Transformers						
Seed Cotton	Manual loading/unloading from tractor drawn trailers	J. Deere	Model 1030				
Conveyance within Ginnery	Manual feeding into under-floor suction pipe, within remote s/c mixing room, using suction fans.	Murray Piritininga	Dual 45/50 Fans (1) (2)	1976 "	10662401 "	56 KW 56 KW	Casings worn - dust escaping to gin room.
	Feed Control Unit (C.F.M.) consisting of:-	"	3 Cyl. Airline Cleaner	"	10861501		Some welding and patching.
		"	96" Air separator	"	N/A		
		"	Upper Vac. Wheel	"	10671601	22 KW	
		"	Storage Hopper	"	10659201		
		"	Lower Vac. Wheel	"	10671601		Removed - straight through suction
		Reeves	Variable feed drive	"	N/A		Replaced with locally made fixed speed drive
	Conveyor Distributor	Murray Piritininga	16" OD Screw		N/A	6 KW	Satisfactory
	Overflow Hopper (A.O.F)	"	Automatic Overflow Variable Feed Drive		N/A N/A		Replaced with fixed speed drive.
	Overflow Separator	"	52.3/8" Air Separator C/W Vac. Wheel	"	10682501		Operation/condition satisfactory
S/C Conditioning	Humidification, using fans	S. Jackson	Humidaire Unit Push Fan 35/40 Pull Fan 35/40	" " "	N/A 10860401 10860401	30 KW 30 KW	Condition satisfactory-not in use Belts Removed Not in place. Now used as o/flow sep. pull fan.

S/C Cleaning	Hand Picked s/c cleaners	Murray Piritininga	2 No. 72" x 7 cylinder inclined cleaners 35/40 Trash/Pull Fan(1) 35/40 Trash/Pull Fan(2)	1976 " " "	10662301 N/A 10564201 10860401	15 KW 15 KW 30 KW 30 KW	Operation/condition satisfactory  Casings and piping badly worn and holed.  Operation/condition satisfactory Manual feed control only.
	Gin Feeders	Murray Piritininga Mitchell	3 No. Cotton King Extractors Model CK 2983/1	" "	10662801 10662801 10567201		
	Gin Stands	Saw	3 No. 142 x 18" OD (1) brush gins (2) (3)		10662601 " "	56 KW 56 KW 56 KW	Operation/condition satisfactory Auto gin breast throwouts removed.
	Cotton Seed Seed Conveying	Conveyor below gin stands	" " Sutorbilt	12" OD Screw Vacuum Dropper 8 lb/sq.in.seed blower	" " "	N/A N/A N/A	7.5 KW 19 KW
Trash Removal	Trash Conveying from Gin Stands	Screw Conveyor below gins	48" OD Cyclone and Vacuum Dropper 24' long conveyor 6 No. double bagging spouts.	1976 " "	N/A N/A N/A N/A		Removed Reduced to 12' long Reduced to 2 No. double spouts
			12" OD Screw Vacuum Dropper Trash Fan 35/40	" " "	N/A N/A 10564201	30 KW	Replaced by suction pipe from trash fan. Also acts as Humidaire pull fan.

TABLE 10.3.2 (cont.)

GINNERY INVENTORY : MACHINERY

LOCATION : FAU FACTORY Nr 2

System	Method	Make	Type	Year	Serial Nr	Power	Comment
Cotton Lint Lint Conveying	Saw Brush Draught	Murray	40" wide x 68" OD	1976	N/A	2.2 KW	Some fire damage
	Battery Condenser	Piritininga	29" OD Condenser	"	N/A	30 KW	Satisfactory
		"	V.A. Fan	"	N/A		Satisfactory
	Tramper Feeder - mechanical	"	Pneumatic pusher Compressor	"	N/A	7.5 KW	Satisfactory
Lint Baling	Mechanical Tramper	"	Atlas gear & Chain	"	N/A	15 KW	Tramper foot out of line
	Oil Hydraulic bale press	"	20" x 40" PCX,2 ram up-packing, standard density, revolving boxes	"	N/A		Excessive movement around centre column. Major o/haul urgently required.
Lint Cleaning	Press Pump	Abex	Vane & Piston Pumps(1) (2)	"	N/A	37 KW	Couplings worn - otherwise satisfactory.
	Box Turning - mechanical	Denison	Powered chain drive	1976	N/A	37 KW	Operation satisfactory
	Door locks	Murray	Powered hydraulic	"	N/A	6 KW	Only 2 locks per door in place.
	Saw Type Cleaners	Piritininga	Model 100 - 3 No. (1) (2) (3)	"	10596601 10861101 10596601	6 KW 6 KW	All out of use - cannibalised to service gin stands
		"	29" OD V.A.Fans (1) (2) (3)	"	N/A N/A N/A	15 KW 15 KW 15 KW	All motors removed.
		"	Trash Fan 35/40	"	10693601	30 KW	No vee belt drive.

**Trash Collection**  
**Condenser**  
**Lint Cleaners**

Lint Fly Collection

Murtay  
 Piritingina

Inline Filters  
 3 No. Inline Filters (1)  
 (2)  
 (3)

1976

N/A  
 N/A  
 N/A  
 N/A

0.75 KW  
 0.75 KW  
 0.75 KW  
 0.75 KW

All inline filters dismantled  
 V/A Fans discharging to atmosphere

Lint Fly Suction Fan  
 Cyclones

"

35/40 Fan  
 10 No. 48" OD

"

N/A  
 N/A

30 KW  
 -

Not in place  
 Excessive dust and trash discharging  
 to atmosphere, through holed cyclone

OPERATIONAL MEMORANDUM - INVENTORY

TABLE 10-23

LOCATION: ENVIRONMENTAL

Continued

## GINNERY INVENTORY : MACHINERY

TABLE 10.3.3

LOCATION : FAU FACTORY Nr 3

System	Method	Make	Type	Year	Serial Nr	Power	Comment
Power Supply	NEC Network Transformers						
Seed Cotton Conveyance from Yard	Manual loading/unloading from tractor drawn trailers	J. Deere	Model 1030				
Conveyance within Ginnery	Manual feeding into under-floor suction pipe, within remote s/c mixing room, using suction fans.	Murray Piritininga	Dual 45/50 Fans (1) (2)	1976	10697101	56 KW 56 KW	Casings worn and holed. Dust escaping into gin atmosphere
	Feed Control Unit (C.F.M.) consisting of:-	"	3 Cyl.-Airline Cleaner	"	N/A		Operation and condition satisfactory
		"	96" Air separator	"	N/A		
		"	Upper Vac. Wheel	"	10671601	22 KW	
		"	Storage Hopper	"	N/A		
		"	Lower Vac. Wheel	"	10671601		
		Reeves	Variable feed drive	"	N/A		Replaced with locally made fixed speed drive
	Conveyor Distributor	Murray Piritininga	16" OD Screw			6 KW	Satisfactory
	Overflow Hopper (A.O.F)	Reeves	Automatic Overflow Variable Feed Drive		10683201	0.75 KW	Replaced with fixed speed drive
	Overflow Separator	"	52.3/8" Air Separator C/W Vac. Wheel	"	N/A		Operation and condition satisfactory
S/C Conditioning	Humidification, using fans	S.Jackson	Humidaire Unit Push Fan 35/40 Pull Fan 35/40	"	279331275	30 KW	Not in use - intact
				"	10860401	30 KW	

S/C Cleaning	Hand Picked s/c cleaners	Murray Piritininga	2 No. 72" x 7 cylinder inclined cleaners 35/40 Trash/Pull Fan(1) 35/40 Trash/Pull Fan(2)	1976	N/A	15 KW 15 KW 30 KW 30 KW	Operation/condition satisfactory
	Gin Feeders	Murray Piritininga Mitchell	3 No. Cotton King Extractors Model CK 2983/1	"	10662801 10567201 10662801		Operation/condition satisfactory. Manual feed control only.
Gin Stands	Saw	Murray Piritininga	3 No. 142 x 18" OD (1) brush gins (2) (3)	"	10684601	56 KW 56 KW 56 KW	Operation/condition satisfactory. Auto gin breast throwouts removed.
Cotton Seed	Conveyor below gin stands	"	12" OD Screw	"	N/A	7.5 KW	Drive relocated at opposite end
Seed Conveying		"	Vacuum Dropper	"	N/A	19 KW	
		Sutorbilt	8 lb/sq.in.seed blower	"	N/A		
		Murray Piritininga	48" OD Cyclone and Vacuum Dropper	1976	N/A		Removed
		"	24' long conveyor	"	N/A	7.5 KW	Reduced to 12' long.
		"	6 No. double bagging spouts.	"	N/A		Reduced to 2 No. double spouts.
Trash Removal		"	12" OD Screw	"	N/A		
Trash Conveying from Gin Stands	Screw Conveyor below gins	"	Vacuum Dropper	"	N/A		Replaced with suction pipe to trash fan.
		"	Trash Fan 35/40	"	N/A	30 KW	

Continued/-----

TABLE 10.3.3 (cont.)

GINNERY INVENTORY : MACHINERY

LOCATION : FAU FACTORY Nr 3

System	Method	Make	Type	Year	Serial Nr	Power	Comment	
Cotton Lint Lint Conveying	Saw Brush Draught	Murray Piritininga	40" wide x 68" OD 29" OD Condenser V.A. Fan	1976 " "	N/A 10566601	2.2 KW 30 KW	Some fire damage.	
	Battery Condenser	"		"				
	Tramper Feeder - mechanical	"	Pneumatic pusher Compressor	" "	105395L	7.5 KW	Satisfactory "	
Lint Baling	Mechanical Tramper	"	Atlas gear & Chain 20" x 40" PCX,2 ram	"	10854938	15 KW	Tramper foot mis-aligned. Excessive movement around centre column. Major o/haul urgently reqd.	
	Oil Hydraulic bale press	"	up-packing, standard density, revolving boxes	"				
Lint Cleaning	Press Pump	Abex Denison	Vane & Piston Pumps(1) (2)	"	N/A	37 KW 37 KW	Some wear on couplings.	
	Box Turning - mechanical Door locks	Murray Piritininga	Powered chain drive Powered hydraulic	1976 "	N/A N/A	6 KW 6 KW	Satisfactory Only 2 locks per door. Centre lock missing.	
	Saw Type Cleaners		"	Model 100 - 3 No. (1) (2) (3)	" " "		19 KW 19 KW 19 KW	All 3 cannibalised to service gin stands.
				29" OD V.A.Fans (1) (2) (3)	" " "	N/A 10860801 10860901	15 KW 15 KW 15 KW	No motors
				Trash Fan 35/40	"	10697101	30 KW	No vee belts

**Trash Collection**

Condenser

Lint Cleaners

Lint Fly Collection

Lint Fly Suction Fan

Cyclones

Murray

Piritininga

Inline Filters

3 No. Inline Filters (1)

(2)

(3)

35/40 Fan

10 No. 48" OD

1976

"

"

"

"

"

N/A

N/A

N/A

N/A

N/A

N/A

0.75 KW

0.75 KW

0.75 KW

0.75 KW

30 KW

-

10000001  
10000001  
11111

578 LBS 221/80  
1000 LBS 221/80  
1000 LBS 221/80

10000001  
10000001  
11111

10000001  
10000001  
11111

All inline filters dismantled  
V-A. fans discharging to atmosphere.

Fan removed.  
Dust and trash escaping to atmosphere  
Cyclones and piping holed.

Removed  
Reduced to 12"  
Reduced to 2 No. double spools

N/A  
N/A  
N/A  
N/A  
N/A  
N/A

"  
"  
"  
"  
"

12" OD Screen  
Vacuum Dragger  
Trash Fan 35/40

Murray  
Piritininga  
10 No. 48" OD

12" OD Screen  
Vacuum Dragger  
Trash Fan 35/40

10000001  
10000001  
11111

10000001 10000001 11111

10000001 10000001 11111

10000001 10000001 11111

TABLE 10.3.4

LOCATION: FAU FACTORY Nr 4

GINNERY INVENTORY : MACHINERY

System	Method	Make	Type	Year	Serial Nr	Power	Comment
Power Supply	NEC Network Transformers						
Seed Cotton Conveyance from Yard	Manual loading/unloading from tractor drawn trailers	J. Deere	Model 1030				
Conveyance within Ginnery	Manual feeding into under-floor suction pipe, within remote s/c mixing room, using suction fans.	Murray Piritininga	Dual 45/50 Fans (1) (2)	1976	10697101	56 KW 56 KW	Fan casings holed. Dust escaping to atmosphere.
	Feed Control Unit (C.F.M.) consisting of:-	"	3 Cyl. Airline Cleaner	"	N/A		Operation/condition satisfactory.
		"	96" Air separator	"	10861501		
		"	Upper Vac. Wheel	"	10671601	22 KW	
		"	Storage Hopper	"	N/A		
		"	Lower Vac. Wheel	"	10671601		
		Reeves	Variable feed drive	"	N/A		Replaced with fixed speed drive.
	Conveyor Distributor	Murray Piritininga	16" OD Screw		N/A	6 KW	Operation/condition satisfactory
	Overflow Hopper (A.O.F)	"	Automatic Overflow Variable Feed Drive		N/A	0.75 KW	Replaced with fixed speed drive.
	Overflow Separator	"	52.3/8" Air Separator C/W Vac. Wheel		10904301		Pull fan in place. Ser.No. 10942801
S/C Conditioning	Humidification, using fans	S.Jackson	Humidaira Unit Push Fan 35/40 Pull Fan 35/40	"	27933 10860501 10860501	30 KW 30 KW	Not in use

S/C. Cleaning	Hand Picked s/c cleaners	Murray	2 No. 72" x 7 cylinder inclined cleaners	1976	10861001	15 KW	Operation/condition satisfactory
		Piritininga	35/40 Trash/Pull Fan(1)	"	"	15 KW	Casings holed. Trash and dust escaping to gin room.
			35/40 Trash/Pull Fan(2)	"	10904001 10942801	30 KW 30 KW	
Gin Stands	Gin Feeders	Murray	3 No. Cotton King Extractors Model CK 2983/1	"	10671001		Operation/condition satisfactory Manual feed control only
		Piritininga		"	"		
		Mitchell		"			
Gin Stands	Saw	Murray	3 No. 142 x 18" OD (1) brush gins		N/A	56 KW	Operation/condition satisfactory
		Piritininga	(2)		10684601	56 KW	Auto gin breast throwout removed
			(3)		10860701	56 KW	
Cotton Seed	Conveyor below gin stands	"	12" OD Screw	"	N/A	7.5 KW	Drive relocated at opposite end
		"	Vacuum Dropper	"	N/A		
		Sutorbilt	8 lb/sq.in.-seed blower	"	N/A	19 KW	
Trash Removal	Trash Conveying from Screw Conveyor below gins	Murray	48" OD Cyclone and Vacuum Dropper	1976	N/A		Removed
		Piritininga	24' long conveyor	"	N/A	7.5 KW	Reduced to 12'
			6 No. double bagging spouts.	"	N/A		Reduced to 2 No. double spouts.
Gin Stands	Trash Conveying from Screw Conveyor below gins	"	12" OD Screw	"			Replaced by suction pipe from trash fan.
		Murray	Vacuum Dropper	"			Casing holed.
			Trash Fan 35/40	"			30 KW

TABLE 10.3.4 (cont.)

GINNERY INVENTORY : MACHINERY

LOCATION : FAU FACTORY Nr 4

System	Method	Make	Type	Year	Serial Nr	Power	Comment	
Cotton Lint Lint Conveying	Saw Brush Draught	Murray Pirtitininga	40" wide x 68" OD 29" OD Condenser V.A. Fan	1976 " "	10684001	2.2 KW 30 KW	Some fire damage.	
	Battery Condenser	"						
	Tramper Feeder - mechanical	"	Pneumatic pusher Compressor	" "	916975-1	7.5 KW	Satisfactory "	
Lint Baling	Mechanical Tramper	"	Atlas gear & Chain		10953502	15 KW	Satisfactory	
	Oil Hydraulic bale press	"	20" x 40" PCX, 2 ram up-packing, standard density, revolving boxes		N/A		Slight wear on centre column	
Lint Cleaning	Press Pump	Abex Denison	Vane & Piston Pumps(1) (2)		N/A N/A	37 KW 37 KW	Satisfactory	
	Box Turning - mechanical Door locks	Murray Pirtitininga	Powered chain drive Powered hydraulic	1976 "	N/A N/A	6 KW 6 KW	Satisfactory "	
	Saw Type Cleaners	Overflow Separator	"	Model 100 - 3 No. (1)	"	10861201	19 KW	Cannibalised to provide spares for gin stands.
				(2)	"	"	19 KW	
				(3)	"	"	19 KW	
				29" OD V.A.Fans (1)	"	N/A	15 KW	Not in use. Motors removed
			(2)	"	N/A	15 KW		
			(3)	"	N/A	15 KW		
	Trash Fan 35/40	"		"	10942901	30 KW	No vee belts.	

Trash Collection  
 Condenser  
 Lint Cleaners

Lint Fly Collection  
 Lint Fly Suction Fan  
 Cyclones

Murray  
 Piritinga

Inline Filters  
 3 No. Inline Filters (1)  
 (2)  
 (3)

1976  
 " " " " "

N/A  
 N/A  
 N/A  
 N/A  
 N/A  
 N/A

0.75 KW  
 0.75 KW  
 0.75 KW  
 0.75 KW  
 30 KW  
 -

Dismantled. All V.A. fans discharging to atmosphere  
 Not in place.  
 Excessive dust and trash escaping to atmosphere.

ΓΑΛΛ  
 1 x 320 KAV  
 Γενεσις προηγου  
 3 x 1 000 KAV  
 Ελεφονα ΜΑ 3  
 3 x 1 000 KAV  
 Ελεφονα ΜΑ 3  
 3 x 400 KAV  
 3 x 1 000 KAV  
 Ελεφονα ΜΑ 3  
 712 Α' 1 000 sub  
 Κροσσος Υπερηλ. ΓΑΛΛ

couple  
 712 Α υποηλ. καταλ  
 Κροσσος Υπερηλ. ΓΑΛΛ  
 712 Α' 1 000 sub  
 Κροσσος Υπερηλ. ΓΑΛΛ

σε απορ. περιστ  
 ΥΟΡΟ μετ. ποσότητα  
 συμπυκνωτ  
 71 ΚΑ επιδ. υαλοπ. ρυθ  
 Κροσσος Υπερηλ. ΓΑΛΛ  
 ΗΑ επιρ. καταλ

απορ. περιστ  
 MEC  
 σε απορ  
 (Σ.Π. καταλ)  
 MEC-TINA  
 απορ. περιστ  
 βωμετ

ακουστικ  
 collection  
 βωμετ περιστ

717 11 000/322 Α  
 Διαρρηκτηυ στασιμ. βωμετ

ΓΑ επιρ. καταλ

ΗΑ επιρ. καταλ

ΓΟΣΥΛΙΟΝ-FLVN

ΣΥΜΒΕΛΑ ΠΑΝΕΛΙΟΥ ΒΩΜΕΤΣ ΡΥΘΜΓΑ

1976 10 4

TABLE 10.4

GINNERY INVENTORY: POWER SUPPLY

LOCATION: FAU

Power supply	HV switchgear	LV switchgear	Distribution transformers	Power factor correction
NEC-11kV (2 Nr feeders at main NEC substation)	Klockner Moeller 1977 11 kV ring main unit comprising ACBs and isolators at each factory	Klockner Moeller 1977 415 V, 1 600 amp	All 11 000/433 V  Factory Nr 1 2 x 1 000 kVA 2 x 400 kVA  Factory Nr 2 2 x 1 000 kVA  Factory Nr 3 2 x 1 000 kVA  General buildings 1 x 250 kVA	automatic
			1977	

TABLE 11.2

LOCATION: NEW HALFA

INFRASTRUCTURE

Category	Item	Quantity	Description
Water Supply	Electricity	1	Block water pump OGI water distribution
	Water supply	1	Water supply
(a) Firefighting	Water supply	1	Water supply
	Firefighting system	1	Firefighting system in adequate
Drainage	Drainage	1	Drainage system in adequate
	Drainage	1	Drainage system in adequate
Electricity	Electricity	1	Electricity
	Electricity	1	Electricity
Drainage	Drainage	1	Drainage
	Drainage	1	Drainage
Water supply	Water supply	1	Water supply
	Water supply	1	Water supply
Electricity	Electricity	1	Electricity
	Electricity	1	Electricity
Drainage	Drainage	1	Drainage
	Drainage	1	Drainage
Water supply	Water supply	1	Water supply
	Water supply	1	Water supply
Electricity	Electricity	1	Electricity
	Electricity	1	Electricity
Drainage	Drainage	1	Drainage
	Drainage	1	Drainage

LOCATION: NEW HALFA

TABLE 11.1

INFRASTRUCTURE

Category	Item	Quantity	Description
Water Supply	Electricity	1	Block water pump OGI water distribution
	Water supply	1	Water supply
(a) Firefighting	Water supply	1	Water supply
	Firefighting system	1	Firefighting system in adequate
Drainage	Drainage	1	Drainage system in adequate
	Drainage	1	Drainage system in adequate
Electricity	Electricity	1	Electricity
	Electricity	1	Electricity
Drainage	Drainage	1	Drainage
	Drainage	1	Drainage
Water supply	Water supply	1	Water supply
	Water supply	1	Water supply
Electricity	Electricity	1	Electricity
	Electricity	1	Electricity
Drainage	Drainage	1	Drainage
	Drainage	1	Drainage

## GINNERY INVENTORY:BUILDINGS

LOCATION:NEW HALFA

TABLE 11.1

Building	Description	Approximate dimensions L x W x H (m)	Comments
Main Buildings Ginning factory (3 Nr)	Structure :	43.5 x 13 x 6	In good condition, no remedial works required. An increase in factory width is desirable for better ventilation and ease of movement.
	Walls :		
	Roof :		
	Floor :		
Seed room (3 Nr)	Structure :	13 x 10 x 5	In good condition, no remedial works required.
	Walls :		
	Roof :		
	Floor :		
Mixing room (3 Nr)	Structure :	14 x 13 x 5	In reasonable condition, no remedial works required. An increase in width is desirable for increased working space.
	Walls :		
	Roof :		
	Floor :		
Main stores (3 Nr)	Structure :	100 x 40 x 7	In good condition, no remedial works required. Mainly used for agricultural purposes.
	Walls :		
	Roof :		
	Floor :		
Workshop and seed treatment building	Construction same as main stores	60 x 40 x 5	In good condition, no remedial works required.
Office	Structure :	50 x 10 x 4	In good condition, no remedial works required.
	Walls :		
	Roof :		
Other Buildings Fire office and station Latrines Storekeeper's office Canteen Guard room	Brick walls and GCI sheeting	various	In good condition, no remedial works required.

**GINNERY INVENTORY:INFRASTRUCTURE**

**TABLE 11.2**

LOCATION:NEW HALFA

Facility	Description	Comments
<b>Water Supply</b> (a) <b>Firefighting</b>	From municipal supply and from pumping from adjacent canal. Municipal supply feeds 2 Nr 24 m high tanks (each 18 000 gallons). 37 hydrants in factory yard are fed directly from the mains and also from the tank. Water is also pumped from irrigation canal to 55 000 gallon ground tank from where it is pumped to tenders with hoses. Sprinkler systems in the factories are fed from the mains/high level tank.	Firefighting system is adequate.
(b) <b>Domestic and other uses</b>	From municipal supply.	No problems reported.
<b>Surface Water Drainage</b>	Water is drained by open drains connected to main town drain on western side of site.	Water is retained in factory area until water level in town drain falls. Yard area is very flat.
<b>Sewage Disposal</b>	Aqua privies.	
<b>Roads/Access</b>	Good system of gravel access roads within the site and a good gravel connect the factory to main road system. Sudan Railways siding.	Access from factory to town passes over three town drains on which proper crossings/culverts are required.
<b>Fencing</b>	Plain wire with steel angle posts.	In good condition.
<b>Platforms and Hardstandings</b>	None.	
<b>Houses</b>	Adjacent to the ginnery site are : Senior staff houses     2 Middle staff houses    13 Junior staff houses     119	24 of the houses are used by agricultural staff and 3 houses are used as dispensary, club, and co-operative shop.
	Constructed in brick with GCI sheeting roofs with concrete tile floors. Sanitation generally by aqua privies.	

## GINNERY INVENTORY : MACHINERY

TABLE 11.3.1

LOCATION : NEW HALFA FACTORY Nr 1

System	Method	Make	Type	Year	Serial Nr	Power	Comment
Power Supply	Kashim El Girba Grid	Harath Ltd.	Rolls Royce 'D' Range V8 Diesel Engine Leroy Somers (France) Alternator TA 401053	1983	D500G-106 Build No.2261 56427/1 Set no. 82407		Power supply very erratic
	New Halfa Sugar Corporation						Power for one factory only-seasonal
	Diesel Generators - 1 No.						Installed as permanent solution to erratic power supply. Cable from alternator to factory burnt out. No change over switch to enable factory to run from mains.
Seed Cotton							
Conveyance from yard	Manual loading/unloading from tractors vehicles or tractor/trailer						
Conveyance within ginnery	Manual feeding to telescope suction pipe, within remote s/c mixing room, using suction fans.	Platt/ Lummus	DF176 Fans (2)	1967	N/A	75 KW	Mixing room too small-extension required. Second suction telescope required.
	Feed Control Unit (A.S.H.)	"	HM Air Separator Vacuum Wheel Feed Motor	"	PG 23	12 KW 4 KW	Variable feed drive replaced with fixed speed drive from main motor.
	Conveyor Distributor	"	16" OD Screw		N/A	6 KW	Operation/condition satisfactory
	Overflow Hopper (A.O.H.)	"	Automatic Overflow		PG 23	2 KW	Operation/condition good
	Overflow separator	Platt/ Lummus	72" Type C Separator F 156 Fan	1967 "	PG 23 N/A	7.5 KW 12 KW	Operation/condition good " "
S/C Conditioning	NIL						Space available for Humidaire

S/C Cleaning	Hand picked S/C cleaners	Platt/ Lummus	72" x 6 cylinder inclined suction DF 176 Double Fan	(1) (2)	1967	N/A	12 KW 12 KW 56 KW	Operation/condition good " " " " " "
Gin Stands	Gin Feeders	"	Model 400 Extractors		"	2-36/2-37/2-38		Feed control replaced with fixed speed drive-unsatisfactory. Fixed speed feed may be cause of saw overloading and many gin fires. Hydraulic agitator drive replaced by vee belt drive from main motor.
Cotton Seed	Saw	"	3 No. 128 x 12" OD brush gins	(1) (2) (3)	"	1 - 25 1 - 25 1 - 25	56 KW 56 KW 56 KW	
Seed Conveying	Conveyor below gin stands	"	12" OD Screw Vacuum dropper		"	N/A N/A	3 KW	Operation/condition good " " "
Trash Removal		Holmes	6" Seed Blower 30 ton Hopper c/w 4 double bagging spouts		"	16592 N/A	12 KW	" " " " " "
Trash Conveying from gin stands	Screw conveyor below gin stands	Platt/ Lummus	12" OD Screw Vacuum Dropper F176 Fan		"	N/A N/A N/A		Operation/condition good " " " " " "
Cotton Lint					"		30 KW	
Lint Conveying	Saw Brush draught Battery Condenser	Platt/ Lummus	40" wide x 60" OD 36" OD V.A. Fan		1967	PG 23	2 KW 30 KW	Operation/condition good - some fire damage to seals.
	Tramper feeder - mechanical	"	Hi-cap.lint feeder		"	N/A	4 KW	Operation/condition good

TABLE II.3.1 (cont.)

GINNERY INVENTORY : MACHINERY

LOCATION : NEW HALFA FACTORY Nr 1

System	Method	Make	Type	Year	Serial Nr	Power	Comment
Lint Baling	Mechanical tramper	Platt/ Lummus	Gear & chain 20" x 41", single ram up-packing, standard density, revolving box	1967	N/A	20 KW	Operation/condition good
	Oil hydraulic bale press			"	PG 23-2	"	"
Press Pump	Press Pump	Abex	H4 Pump Unit	"	MPTU/400/JG	56 KW	Some oil leaks
		Denison			19085-No.2		
Box turning - mechanical Door Locks	Box turning - mechanical Door Locks	Platt/ Lummus	Powered chain drive Hand hydraulic	"	N/A	4 KW	"
				"	N/A	4 KW	"
Lint Cleaning	Air Stream cleaners Trash conveyor	"	Jetstream	"	10-10	2 KW	Operation/condition good
		"	6" Screw	"			"
Trash Collection	Lint Fly collection	"	72" lint fly catcher in expansion room F156 Scavenging Fan	"	N/A		Screen fire damaged
				"	NA	7.5 KW	Not in use
Cyclones	Cyclones	"	4 x 28" OD 4 x 32" OD 4 x 34" OD 2 x 2 x 32" OD	"	N/A		
				"	N/A		
				"	N/A		
				"	N/A		

S/C Clearing	Hand picked S/C elements	Plant/Lumens	72" x 6 cylinder Inchless suction OF 175 Double Fan	1967	12 KW 12 KW 56 KW	Operation/condition good
2/C Compressor	Gas Feeders	"	Model 400 Extractors	"	2-28	Hydraulic feed control replaced by feed speed dial.
Gas Strands	Saw	"	3 No. 125 x 12" OD (1) Krupp Fan	"	1-25	Fixed feed control causing overloading of gas lines and fires.
Carbon Sand	Gasoline solvent	Gamma Lumens	250 lbs. C. solvent	"	1-24 1-25	Hydraulic control body was built dirt.
Sand Conveying	CONVEYOR BELT/DRUM STANDS	"	4000 lbs. G-1000	"	M/V	"
Truck Removal	Lead Convey (V2H)	"	165 600 lbs. Vaccum cleaner	"	N/A	Condition operation good
CONVEYOR, AIRY	2/C mixed tank' sand' storage (see enclure file' AIRY) source	Holmes	Electrofan Aircraft engine 1/4" V	"	"	"
Iron in stands lead	Lead Convey (V2H)	"	4000 lbs. G-1000	"	60-52	Operation good
Collection (see enclure)	2/C mixed tank' sand' storage (see enclure file' AIRY) source	Gamma Lumens	600 lbs. G-1000 Vaccum Cleaner F175 Fan	"	M/V	Condition good by second section Exhausted 2000 lbs. Vaccum
Line Conveying	Saw brush storage	Plant/ Lumens	60" wide x 60" OD 40" OD V.A. Fan	1967	PG 23 N/A	"
Gasoline	Transfer 1000 lbs. solvent	"	10" x 10" fan 1000	"	M/A 2000 lb	Condition good by second section Exhausted 2000 lbs. Vaccum

OPERATION: VIEW PHOTO 1 & 2

1967 11 23

TABLE 11.3.2

LOCATION : NEW HALFA FACTORY Nr 2

## GINNERY INVENTORY : MACHINERY

System	Method	Make	Type	Year	Serial Nr	Power	Comment
Power Supply	Kashim El Girba Grid New Halfa Sugar Corporation						Erratic Power Supply. Available to one factory only.
Seed Cotton Conveyance from yard	Manual loading/unloading from contractors vehicles or tractor/trailer	Platt/ Lummus	DF176 Fans (2)	1967	N/A	75 KW	Extension required to mixing room plus second suction telescope.
Conveyance within ginnery	Manual feeding to telescope suction pipe, within remote s/c mixing room, using suction fans.	"	HM Air Separator Vacuum Wheel Feed Motor	"	PG-23	12 KW 4 KW 6 KW	Operation Good " " "
	Feed Control Unit (A.S.H.)	"	16" OD Screw				
	Conveyor Distributor	"	Automatic Overflow		N/A	2 KW	"
	Overflow Hopper (A.O.H.)	"					
	Overflow separator	Platt/ Lummus	72" Type C Separator F 156 Fan	1967 "	PG 23 N/A	7.5 KW 12 KW	Operation/condition good " "
S/C Conditioning							NIL

Category	Equipment	Year	Power	Condition/operation
S/C Cleaning	Hand picked S/C cleaners	1967	12 KW	good
			12 KW	"
			56 KW	"
Gin Stands	Gin Feeders	"	2-38	Hydraulic feed control replaced by fixed speed drive.
	Saw	"	56 KW	Fixed feed control causing overloading of gin saws and fires.
		"	56 KW	Hyd. agitator replaced by vee belt drive.
Cotton Seed				
Seed Conveying	Conveyor below gin stands	"	3 KW	Condition/operation good
		"	12 KW	"
		"	30 KW	"
Trash Removal				
Trash Conveying from gin stands	Screw conveyor below gin stands	"	30 KW	Condition/operation good
		"		"
		"		"
Cotton Lint				
Lint Conveying	Saw Brush draught Battery Condenser	1967	2 KW	Some fire damage
		"	30 KW	"
	Tramper feeder - mechanical	"	4 KW	"

TABLE 11.3.2 (cont.)

GINNERY INVENTORY : MACHINERY

LOCATION : NEW HALFA FACTORY Nr 2

System	Method	Make	Type	Year	Serial Nr	Power	Comment
Lint Baling	Mechanical trampler	Platt/ Lummus	Gear & chain 20" x 41", single ram up-packing, standard density, revolving box	1967	N/A PG 23-1	20 KW	Condition/operation good
	Oil hydraulic bale press			"			" " "
Lint Cleaning	Press Pump	Abex Denison	H4 Pump Unit	"	N/A	56 KW	" " "
	Box turning - mechanical Door Locks	Platt/ Lummus	Powered chain drive Hand hydraulic	"	N/A N/A N/A N/A	4 KW 4 KW	" " " " " "
Trash Collection	Air Stream cleaners Trash conveyor	" "	Jetstream 6" Screw	"	N/A	2 KW	Operation/condition good
	Lint Fly collection	"	72" lint fly catcher in expansion room F156 Scavenging Fan	"	N/A	7.5 KW	Screen fire damaged Not in use
Cyclones			4 x 28" OD	"			
			4 x 32" OD	"			
			4 x 34" OD	"			
			2 x 2 x 32" OD	"			
Cyclones			DL 130 Corpio Lou	"			
			propag anastou (3)	"			
			35. x e alpaqst (1)	"			

3/8 Drawing 2/3 Description	Part Name / %C Material	Part / Material	72" x 8 cylinders Inboard section OF 176 Double Fan	1562	N/A	12 KW	Operation / condition good
		Gamma Steel	1 120 Fan ΔΜαθητικό ελκυστήρα	1803	208 33	43 KW	Fixed control units replaced with fixed speed.
On Stand	ΟΒΑΝΤΑ ΗΕΒΕΣ (ΥΠΗΥ)	" "	ΥΠΕΡΑΥΤΟΜΑΤΙΣΜΟΣ (1) ΒΑΡΕΤΑ ΓΙΝΑ (2) 36-00 ΣΥΣΤΗΜΑ (3)	"	1-23	505 KW	Overhauling of pin jaws causing numerous fires. Hydraulic agitator drifted into position. Complete drive from main motor.
Carbon Band		" "	1000 ΜΕΤΡΑ ΑΝΟΙΧΤΗ ΔΡΟΣΗ	"	60 699	45 KW	Τελειωσα ΡΑ 12000 ελκυστήρα Εξαρτήματα (αυτοματισμοί/Δροση)
Seed Conveyor	1.000-0000000000 (MATERIALS)	" "	Vacuum dropper 6" Seed Blower 30 ton Hopper c/w DB100-0000-0000000000	"	N/A	12 KW	τοξευαδρα αυτοματ' τρομα βυθ' ελκυστη' ελκυστη Εξαρτησων τελειωσα ρα ελκ
Drum	εξοχιστο τρομα' τρομα' ελκυστη τρομα'	Aluminum Gamma	"	"	N/A	32 KW	
Coalstack Motor	τρομα' τρομα' ελκυστη τρομα'	Steel	DB100-0000-0000000000	1803	N/A		
Aluminum Receiver	συλλεκτησ τρομα' ελκυστη/τρομα'	Part/ Material	12" OD Screw Vacuum Dropper 1776 Fan	"	N/A	30 KW	
Coalstack Motor	τρομα' τρομα' ελκυστη τρομα'	Gamma	ΥΠΕΡΑΥΤΟΜΑΤΙΣΜΟΣ ΔΥ 001022 ΓΑΡΟΛ ΤΡΟΜΑΤΑ (Α.Ε.ΡΟΣ)	"	N/A		
Carbon Line	τρομα' τρομα' ελκυστη τρομα'	Gamma	AB Drive 100000 30" wide x 40" OD 36" OD V.A. Fan	1863	208 40' 85002 2083341 Drive No' 5520		ηυαυα ρα τωσ' Δησρ τρομα' εξαρτη-τρομα' ελκυστη τρομα' ελκ αυτοματ' τρομα' ελκυστησ τρομα'
Unit Conveyor	τρομα' τρομα' ελκυστη τρομα'	Part/ Material	30" wide x 40" OD 36" OD V.A. Fan	1867	D2000-100 FG-13	2 KW	τρομα' ελκυστη ρα τρομα' ελκυστη εξαρτησ τρομα' ελκυστησ τρομα' ελκυστη εξαρτησ τρομα' ελκυστησ τρομα' ελκυστη
Lower Drive	τρομα' τρομα' ελκυστη τρομα'	Gamma		"	N/A	30 KW	
Drum	τρομα' τρομα' ελκυστη τρομα'	Part/ Material	60-00-0000000000	1803	208 33		

ΓΟΣΥΛΙΟΝ : ΝΕΜ ΗΝΓΛΥ ΕΥΣΙΟΡΙΑ ΜΡ 2

LVBE TI 1732

ΕΠΙΧΕΙΡΗΣΙΑ : ΕΥΣΙΟΡΙΑ ΜΡ 2

## GINNERY INVENTORY : MACHINERY

TABLE 11.3.3

LOCATION : NEW HALFA FACTORY Nr 3

System	Method	Make	Type	Year	Serial Nr	Power	Comment
Power Supply	Kashim El Girba Grid New Halfa Sugar Corporation Diesel Generators - 1 No.	Harath Ltd.	Rolls Royce 'D' Range V8 Diesel Engine Leroy Somers (France) Alternator TA 401053	1983	D500G-104 Build No. 2259 56426/1 Set No. 82406		Erratic power supply. Sufficient power for one plant only. Main cable to factory burnt out shortly after installation. No change-over switch installed - unable to use grid power.
Seed Cotton Conveyance from yard	Manual loading/unloading from contractors vehicles or tractor/trailer	Platt/ Lummus	DF176 Fans (2)	1967		75 KW	Extension required to s/c mixing room plus second suction telescope.
Conveyance within ginnery	Manual feeding to telescope suction pipe, within remote s/c mixing room, using suction fans.	"	HM Air Separator Vacuum Wheel Feed Motor	"	PG 23	12 KW 4 KW	Good condition. Feed control replaced by fixed speed drive.
	Conveyor Distributor	"	16" OD Screw			6 KW	Operation/condition good.
	Overflow Hopper (A.O.H.)	"	Automatic Overflow			2 KW	" " "
S/C Conditioning	Overflow separator	Platt/ Lummus	72" Type C Separator F 156 Fan	1967 "	PG 23	7.5 KW 12 KW	
	NIL						

S/C Cleaning	Hand picked S/C cleaners	Platt/ Lummus	72" x 6 cylinder inclined suction DF 176 Double Fan	1967	N/A N/A	12 KW 12 KW 56 KW	Operation/condition good
	Gin Feeders	"	Model 400 Extractors	"	2-38		Feed control units replaced with fixed speed.
Gin Stands	Saw	"	3 No. 128 x 12" OD (1) brush gins (2) (3)	"	1-23 1-24 1-25	56 KW 56 KW 56 KW	Overloading of gin saws causing numerous fires. Hydraulic agitator drive replaced by vee belt drive from main motor.
Cotton Seed							
Seed Conveying	Conveyor below gin stands	"	12" OD Screw Vacuum dropper	"	N/A N/A	3 KW	Operation/condition good
Trash Removal		Holmes	6" Seed Blower 30 ton Hopper c/w 4 double bagging spouts	"	N/A N/A N/A	12 KW	"
Trash Conveying from gin stands	Screw conveyor below gin stands	Platt/ Lummus	12" OD Screw Vacuum Dropper F176 Fan	"	N/A N/A N/A		"
Cotton Lint						30 KW	"
Lint Conveying	Saw Brush draught Battery Condenser	Platt/ Lummus	40" wide x 60" OD 36" OD V.A. Fan	1967 "	PG-23 N/A	2 KW 30 KW	Some fire damage
	Tramper feeder - mechanical	"	Hi-cap.lint feeder	"	N/A	4 KW	

GINNERY INVENTORY : MACHINERY

TABLE 11.3.3 (cont.)

LOCATION : NEW HALFA FACTORY Nr 3

System	Method	Make	Type	Year	Serial Nr	Power	Comment
Lint Baling	Mechanical trampler	Platt/ Lummus	Gear & chain 20" x 41", single ram up-packing, standard density, revolving box	1967	N/A	20 KW	Operation/condition good Boxdogs need attention also centre column brgs.
	Oil hydraulic bale press			"	PG 23-3		
Press Pump		Abex Denison	H4 Pump Unit	"	MPTU-400-J6 19058 No.1	56 KW	Operation/condition good
	Box turning - mechanical Door Locks	Platt/ Lummus	Powered chain drive Hand hydraulic	" "	N/A N/A	4 KW 4 KW	" "
Lint Cleaning	Air Stream cleaners	"	Jetstream	"	10-10	2 KW	Operation/condition good
	Trash conveyor	"	6" Screw	"			"
Trash Collection	Lint Fly collection	"	72" lint fly catcher in expansion room	"	N/A		Screen fire damaged
	Cyclones		F156 Scavenging Fan	"	N/A	7.5 KW	Not in use
			4 x 28" OD	"	N/A		
			4 x 32" OD	"	N/A		
			4 x 34" OD	"	N/A		
			2 x 2 x 32" OD	"	N/A		
S/C Conditioning							
S/C Control							

<b>Workshops</b>	<b>Maintenance</b>	<b>Indian</b>	<b>Centre Lathe 3500 x 700 swing Centre Lathe 800 x 250 swing Milling machine Shaper machine Grinder Drilling m/c Welding equipment. Gas &amp; Electric.</b>	<b>1969</b>	<b>N/A</b>	<b>Although fairly new lathe beds are badly worn, making true turning impossible.  Recommend replacement.  Workshop otherwise adequate</b>
<b>Seed Dressing</b>	<b>Heat sterilizing and chemical powder application against pests</b>	<b>Richard Simmons</b>	<b>Screw conveyor from Bucket elevators</b>	<b>1969</b>	<b>N/A</b>	<b>Boiler sterilizer unit defunct Powder application mint condition/operation satisfactory.</b>
	<b>Chemical powder application units 2 No.</b>	<b>German</b>	<b>Screw conveyor from screw elevators</b>	<b>N/A</b>	<b>N/A</b>	<b>Not in use - although appear to be in order.</b>

GINNERY INVENTORY: POWER SUPPLY

TABLE 11.4

GINNERY INVENTORY: POWER SUPPLY

LOCATION: NEW HALFA

Power supply	HV switchgear	LV switchgear	Distribution transformers	Power factor correction
NEC-11kV	11 kV, 150 A, 250 MVA Lucy ring main unit for each factory (NEC owned)	415 V, 800 A, AEI 'Minilink' switchboard for each factory	<b>Factory Nr 1</b> 1 x 750 kVA  <b>Factory Nr 2</b> 1 x 750 kVA  <b>Factory Nr 3</b> 1 x 750 kVA	-

Description

Comments

Water Supply

Water pumped from Main Hole to 30 m high tank (16 000 gallons) which is connected to 3 hydrants in factory yard and hose reels in factory.

Firefighting system is adequate.

Latrine houses  
2 beds bars area  
Office  
Domestic and  
Line/Factory uses  
Other buildings

Untreated water is pumped from the river to 7 m high tanks  
pipes to factory and housing area. 100 new walls 85 m deep  
are under construction, together with two new 7 m high  
(5 300 gallon) tanks.

Essence of concrete

Surface Water  
Waste  
Sewage Disposal

30 x 15 x 4' 2

Concrete  
No special  
: GCI  
: steel  
: Aquatic

Roads/Across  
Office

No special  
to river to the east  
Sudan railway station.

Concrete  
No special  
to river to the east  
to concrete

Fencing  
Quality Vegetal and  
Waste buildings

Barbed  
: pick  
: steel  
: 13 x 12 x 02

Concrete  
to concrete

Houses  
Principal

The following houses, which are owned by the  
located adjacent to the

Only one house, junior type, is occupied by  
staff. are in private  
accommodation.

Senior staff houses  
Middle staff houses  
Junior staff houses

4  
10  
8

CONCRETE

The senior and middle houses are constructed of brick with  
GCI sheeting roofs. The junior houses are constructed of  
mud. Ventilation is by pit latrines.

10000 15 1

TABLE 12.1

## GINNERY INVENTORY: BUILDINGS

LOCATION: ZEIDAB

Building	Description	Approximate dimensions L x W x H (m)	Comments
<b>Main Buildings</b> Ginning factory	Structure : steel framed structures and trusses Walls : brick infill Roof : GCI sheeting Floor : concrete	73 x 15 x 65	In reasonable condition, no remedial works required.
Office	Structure : load bearing brick Roof : jack arches Floor : concrete	28 x 18 x 40	In good condition, no remedial works required. Also used as regional office for Northern Agricultural Corporation.
Stores 3 Nr	Structure : steel framed Walls : GCI sheeting Roof : GCI sheeting Floor : concrete	24 x 12 x 4.5	In good condition, no remedial works required. Used by Northern Agricultural Corporation for general agricultural purposes.
<b>Other Buildings</b> Firefighting office Spare parts store Pump houses	Brick wall and GCI sheeting roof	various	Reasonable condition.

## GINNERY INVENTORY:INFRASTRUCTURE

LOCATION:ZEIDAB

## Comments

## Description

## Facility

**Water Supply****(a) Firefighting**

Water pumped from Main Nile to 30 m high tank (16 000 gallons) which is connected to 3 Nr hydrants in factory yard and hose reels in factory.

Firefighting system is adequate.

**(b) Domestic and other uses**

Untreated water is pumped from the river to 7 m high tanks (5 500 gallons each) and distributed by galvanised steel pipes to factory and housing area. 100 new wells 85 m deep are under construction, together with two new 7 m high (5 500 gallon) tanks.

**Surface Water Drainage**

No special provisions.

No problems reported. Water drains naturally to Nile.

**Sewage Disposal**

Aqua privies.

**Roads/Access**

No surfaced roads to or within ginnery site. Bales and seed are evacuated from the site by river to the east bank and Sudan Railways station.

**Fencing**

Barbed wire and steel angles in part and mud wall in parts.

**Platforms and Hardstandings**

None.

**Houses**

The following houses, which are owned by the Agricultural Corporation, are located adjacent to the ginnery :

Senior staff houses	4
Middle staff houses	10
Junior staff houses	8

The senior and middle houses are constructed of brick with GCI sheeting roofs. The junior houses are constructed of mud. Sanitation is by pit latrines.

Only one house, junior type, is occupied by ginnery staff. Other staff are in private accommodation.

## GINNERY INVENTORY : MACHINERY

LOCATION : ZEIDAB

TABLE 12.3

System	Method	Make	Type	Year	Serial Nr	Power	Comment
<b>Power Supply</b>	Town supply - diesel gens. Transformers - nil.						
<b>Seed Cotton</b>							
Conveying from Yard	Manual - by hand truck						
Conveying within ginnyery	Manual feeding to gin auto feed hoppers, from floor area behind gin stands.	Platt	Lattice type		N/A		Very small storage area and access. Limiting factor should expansion of crop result in the future.
S/C Cleaning	Nil Machinery						
S/C Conditioning	Nil						
<b>Gin Stands</b>	Roller - 40 No.						
		Platts	30 No. Model 1 S.A.S.R. 10 No. Model 2 S.A.S.R. c/w single stripper roller	1926(or earlier)		150 KW	All gin stands converted to elec. motor drive 1966. Condition fair.
<b>Cotton Seed</b>							
C/S Conveying	Mechanical conveyors in basement		Screw conveyors Bucket elevators	"	N/A	20 KW	Condition good
<b>Scarto</b>							
Recovered c/s	Seed Gribble	Rosedowns	Rotary drum	1926	N/A	12 KW	Condition good
Recovered lint	Manual collection	Platts	2 x 40 x 8" OD saw brush gins.			8 KW	

**Cotton Lint**  
Lint Conveying

Manual using a central runway hand pushed truck. Off-loading onto farfara platform.

Labour intensive

**Lint Conditioning**

Nil

**Lint Baling**

Hydraulic bale press with 2 No. runout boxes, foot tramping only

J. Shaw

2.1/2 ton press

N/A

Extremely old obsolete press. Difficulty in obtaining spares.

**Water Supply**

From river pumps. Overhead storage tanks.

Press Pump

"

Church type 6 ram vertical

**Fire Fighting**

Coventry Climax 4 cyl. Petrol engine Godiva water pump

N/A OK

**Workshops**

Nil Some hand tools

Main repairs carried out at Corpn. workshops.

TABLE 12.4

GINNERY INVENTORY: POWER SUPPLY

LOCATION: ZEIDAB

Power supply	HV switchgear	LV switchgear	Distribution transformers	Power factor correction
Private generation: 1 x 430 kVA, 0.8 pf 750 rpm EECo 2 x 575 kVA 0.8 pf 750 rpm EECo	-	415 V, 600 A combination fuse switchboard with TP & N busbar trunking	None electrical supply received at 415 V from Agric. Corp. power house switchboard via 300 m of o/h line	-

Note: Generators owned by Northern Agric. Corp; power also supplied to local irrigation schemes, etc.

Background

Location

City/State

Plant office

Plant grounds

Core course

Co-located facilities

Office

Firefighting

Firehydrant

Direct building

Plant

Plant

Plant

Plant

Plant

Plant

Plant

Plant

Plant

Plant

Plant

Plant

Plant

Plant

Plant

Plant

Plant

Plant

Plant

Plant

Plant

Plant

Plant

Plant

Plant

Plant

Plant

Plant

Plant

Plant

Plant

Plant

Plant

Plant

Plant

Description

Concrete pipes, asbestos and GCI asbestos  
From municipal supply to concrete ground tank (24,000 gallons)  
and 27 m high tank (24,000 gallons). The high tank is con-  
nected to 2 hydrants in factory yard and water points in  
factory.

Plant : concrete  
Material : GCI asbestos

Plant : GCI asbestos

Plant : GCI asbestos and asbestos  
Material : GCI asbestos

Plant : concrete

Plant : asbestos cement pipe

Plant : asbestos cement pipe

Plant : asbestos cement pipe

Plant : asbestos cement pipe

Plant : asbestos cement pipe

Plant : asbestos cement pipe

Plant : asbestos cement pipe

Plant : asbestos cement pipe

Plant : asbestos cement pipe

Plant : asbestos cement pipe

Plant : asbestos cement pipe

Plant : asbestos cement pipe

Plant : asbestos cement pipe

Plant : asbestos cement pipe

Plant : asbestos cement pipe

Plant : asbestos cement pipe

Plant : asbestos cement pipe

Plant : asbestos cement pipe

Plant : asbestos cement pipe

Plant : asbestos cement pipe

Plant : asbestos cement pipe

Plant : asbestos cement pipe

Plant : asbestos cement pipe

Plant : asbestos cement pipe

Plant : asbestos cement pipe

Plant : asbestos cement pipe

Plant : asbestos cement pipe

Plant : asbestos cement pipe

Comments

in reservoir condition.  
Firefighting system is adequate. Pump supplying  
high level tank needs replacement.

Concrete pipes, asbestos and GCI asbestos  
From municipal supply to concrete ground tank (24,000 gallons)  
and 27 m high tank (24,000 gallons). The high tank is con-  
nected to 2 hydrants in factory yard and water points in  
factory.

in reservoir condition, to remove water necessary  
to pump concrete to level of pipe to be laid.

to pump concrete to level of pipe to be laid.  
Concrete pipes, asbestos and GCI asbestos

Concrete pipes, asbestos and GCI asbestos  
From municipal supply to concrete ground tank (24,000 gallons)  
and 27 m high tank (24,000 gallons). The high tank is con-  
nected to 2 hydrants in factory yard and water points in  
factory.

Comments

Concrete pipes, asbestos and GCI asbestos

Concrete pipes, asbestos and GCI asbestos

TABLE 131

## GINNERY INVENTORY: BUILDINGS

LOCATION: PORT SUDAN

TABLE 13.1

Building	Description	Approximate dimensions L x W x H (m)	Comments
<b>Main Buildings</b>			
Ginning factory	Structure : steel frame, stanchions and trusses Walls : GCI sheeting Roof : GCI sheeting Floor : concrete	120 x 35 x 7.5	In poor condition. All GCI sheeting needs replacing. Smaller structural members badly corroded. Trusses need to be disassembled, cleaned, inspected, members replaced as necessary, painted, reassembled.
Office	Structure : load bearing brickwork Roof : GCI sheeting Floor : concrete tiles	25 x 9.5 x 4	In good condition, no remedial works necessary.
Stores	Structure : steel framed, stanchions and trusses Walls : asbestos cement sheeting Roof : asbestos cement sheeting Floor : concrete	32 x 12.5 x 4 22 x 12.5 x 4	In reasonable condition, no remedial works necessary.
Rebaling press building	Structure : steel framed, stanchions and trusses Walls : GCI sheeting Roof : GCI sheeting Floor : concrete	72 x 15.5 x 6.5	In good condition, no remedial works necessary. Originally built as ginning factory. Some modifications made to install rebaling press.
<b>Other Buildings</b>			
Firefighting office	Concrete blocks, asbestos and GCI sheeting	various	In reasonable condition.
Co-operative shop			
Gate rooms			
Small stores			
Small office			
Car sheds			
Latrines			
Bathroom			

GINNERY INVENTORY:INFRASTRUCTURE

LOCATION:PORT SUDAN

Facility	Description	Comments						
<b>Water Supply</b> (a) Firefighting	From municipal supply to concrete ground tank (34 000 gallons) and 22 m high tank (34 000 gallons). The high tank is connected to 2 hydrants in factory yard and water points in factory.	Firefighting system is adequate. Pump supplying high level tank needs replacement.						
(b) Domestic and other uses	Municipal supply.	Pressure is generally low between 0 and 30 psi.						
<b>Surface Water Drainage</b>	No special provisions.	No problems reported.						
<b>Sewage Disposal</b>	Bucket latrines.							
<b>Roads/Access</b>	No surfaced roads within factory site. Site is adjacent to black top town road and has Sudan Railways siding.							
<b>Fencing</b>	Part in plain wire and part in barbed wire with steel angle.	Barbed wire on three sides of site are badly corroded and require replacement.						
<b>Platforms and Hardstandings</b>	None.							
<b>Houses</b>	<table border="0"> <tr> <td>Senior staff houses</td> <td>3</td> </tr> <tr> <td>Middle staff houses</td> <td>6</td> </tr> <tr> <td>Junior staff houses</td> <td>12</td> </tr> </table>	Senior staff houses	3	Middle staff houses	6	Junior staff houses	12	In good condition.
Senior staff houses	3							
Middle staff houses	6							
Junior staff houses	12							
	are provided adjacent to the factory for ginner staff. Houses are constructed with concrete blocks.							

TABLE 13.3

GINNERY INVENTORY : MACHINERY

LOCATION : PORT SUDAN

System	Method	Make	Type	Year	Serial Nr	Power	Comment
Power Supply	Town supply Transformers	English Electric	Diesel Generators 10750/415V	1956	EBG 10161/4	400 KVA	Good Condition
Seed Cotton Conveying from Yard	Tractor/bogeys Manual loading/ unloading	Ford	4 No.				Only 3 sacks s/c per bogey
Conveying within ginnery	Manual feeding to suction telescopes within 2 s/c stores attached to ginnery - via 16 canvas valve pneumatic elevators		Scirrococo Size D20	"	(1) (2) (3) (4)	13 KW 13 KW 13 KW 13 KW	Fan casings and blade wheels badly worn. Replacements needed
S/C Cleaning	Manual feeding into auto feed hoppers from floor area behind outer rows of gins	Platt	Timber frame - canvas spiked lattice	1930			East wing complete with 40 No. feeders. West wing only 20 feeders intact. 20 dismantled for spares Light dust extraction from suction system Coastal waters result in high ambient humidity.
S/C Conditioning	Nil machinery Nil						4 x 75 KW motors per 20 gin stands. 40 gin stands in East wing complete. West wing gin stands (40 No.) stripped down for spares.
Gin Stands	Roller - 80 No. 40 gins per wing	Platts	Model 1 S/A S/R single stripper roller	1930	N/A	300 KW	

<b>Cotton Seed</b> C/S Conveying	Mechanical conveyors in basement	N/A	1930	Shaker conveyors Bucket elevators	Drive from above 75 KW motor line shaft.
<b>Scarto</b> Recovered C/S Recovered Lint	Seed Gribble Manual	Rosedowns Dobson & Barlow	1930 1930 1930	Rotary drum 2 No. two screen 64 Saw Delinter 70 saw brush gin	Good condition  64 saw delinter originally for use with Acala fuzzy type seed. Now out of use - condition beyond recovery. 70 seed brush gin good.
<b>Cotton Lint</b> Lint Conveying	Manual - using 2 No. hand pushed trucks to farfara platform, via central runways.				
<b>Lint Conditioning</b>	Nil				Not required - high ambient humidity.
<b>Lint Baling</b>	Hydraulic bale press, rotating double boxes lint manually loaded - foot tramping only	J. Shaw	1930	Empire No. 13 310 ton revolving box water hydraulic bale press	Box sizes 39" x 25"  Bales - 420 lb (190 kgs) Standard Density
	Differential rams - 1 per press			5.3/4" x 15" OD ram W.P. 1/2ton & 3 ton sq.in 12" x 15'0" - 1/2ton WP	West wing press used all year round on rebaling on behalf of CPC - bales e x Port Sudan warehouses.
	Accumulator				
	Press Pumps			Triple ram - 3 set vertical 2.5/8" x 6" @ 75 RPM 1/2 ton sq.in. W.P.	(1) 22 KW (2) 22 KW

TABLE 13.3 (cont.)

GINNERY INVENTORY : MACHINERY

LOCATION : PORT SUDAN

System	Method	Make	Type	Year	Serial Nr	Power	Comment
Lugata Recovery Cleaning	Manual Old extractor feeder in storage yard	Platt/ Murray	Super Cleaner		N/A		No longer used - badly corroded - defunct
Workshops	Maintenance	N/A	Centre Lathe 3000 x 700 swing Roller lathe Pillar Drill Grinder Bench vices 6 No. Pipe vice.	N/A (1933)	N/A		All machinery very old and worn out. Recommend replacement
Water Supply Storage	Town Supply Overhead tank		Cast Iron plate 8000 x 7000 x 1800 93000 litres				Possible corrosion. Column holding down bolts corroded away. Footings encased in concrete.
Water Delivery	Centrifugal pump	Mather & Platt	100 gal/min @ 100' head max. Type 3" Numedi		19020	7.5 KW	Pump worn out - replacement needed. No water in tank
Fire Fighting	Sprinkler system in Ginnery gravity fed from o/head tank Hydrants - 4 No - gravity fed from o/head tank Fire pump - draws from ground tank	Mather & Platt " Godiva	Quartzoid bulb type 200°F - Grinnell 2 branch 4 cyl. petrol	1930	Order No. 3408 E/SUD N/A GPC572 1286		In good order Require attention Difficult starting. Requires attention.

TABLE 13.4

GINNERY INVENTORY: POWER SUPPLY

LOCATION: PORT SUDAN

Power supply	HV switchgear	LV switchgear	Distribution transformers	Power factor correction
NEC-11kV	11 kV ring main BTH (NEC owned)	415 V, 1000 A, BTH	1 x 400 kVA, 11 000/415 V, EECo	-

## GINNERY INVENTORY: BUILDINGS

TABLE 14.1

LOCATION: KADUGLI

Building	Description	Approximate dimensions L x W x H (m)	Comments
<b>Main Buildings</b>			
Ginning factory	Structure : steel framed, pipe trusses and stanchions Walls : GCI sheeting Roof : GCI sheeting Floor : concrete	53 x 16 x 7	Generally in good condition. Minor repairs required to GCI sheeting and timber truss in wing extension.
Store	Structure : load bearing brickwork Roof : GCI sheeting Floor : concrete domes	15 x 6 x 4	In good condition, no remedial works required.
Seed dressing room	Structure : load bearing brick, steel roof trusses Roof : GCI sheeting Floor : concrete	13 x 12 x 4.5	In reasonable condition, no remedial works required. Building is no longer used for seed treatment but now used as chemical store.
Offices	Structure : load bearing brickwork Roof : GCI sheeting Floor : concrete	30 x 8 x 4 26 x 4 x 4	In good condition, no remedial works required. Building is mainly used by agricultural staff.
<b>Other Buildings</b>			
Weighing sheds 4 Nr	Brick and GCI sheeting	various	Reasonable condition.
Latrines			
Agricultural rest house			
Chemical store			

TABLE 14.2

GINNERY INVENTORY:INFRASTRUCTURE

LOCATION:KADULGI

Facility	Description	Comments						
<p><b>Water Supply</b> (a) Firefighting</p>	<p>Water pumped from shallow well (22 m) to 1 500 gallon tank to 4 hydrants in factory yard and water points in factory. Fire extinguishers are also provided within the factory.</p>	<p>Effectiveness of system is limited by available water supply.</p>						
<p>(b) Domestic and other uses</p>	<p>Same source and storage as above.</p>	<p>Kadugli suffers from a general water shortage and water from the factory well is taken by tanker for domestic purposes in the town both for ginnery and other corporation staff.</p>						
<p><b>Surface Water Drainage</b></p>	<p>No special provisions.</p>	<p>Water drains naturally to the southeast but sheet flooding enters site from north and west following rains.</p>						
<p><b>Sewage Disposal</b></p>	<p>Bucket latrines.</p>	<p>Access road in very poor condition and is only used during the rains.</p>						
<p><b>Roads/Access</b></p>	<p>No surfaced roads within ginnery site. 600 m long stone access road connects factory with main town roads.</p>	<p>The fence along three sides of the site needs to be realigned to fit town plan factory boundary.</p>						
<p><b>Fencing</b></p>	<p>Plain wire and steel angle posts.</p>	<p>Only 1 ginnery staff member is provided with a house, other staff live in private accommodation in Kadugli. 1 Nr senior staff house and 3 Nr middle staff houses are required to house all senior and middle ginnery staff.</p>						
<p><b>Platforms and Hardstandings</b></p>	<p>None.</p>	<p></p>						
<p><b>Houses</b></p>	<p>The Nuba Mountain Agricultural Production Corporation owns the following houses in Kadugli :</p> <table border="0" data-bbox="878 895 948 1855"> <tr> <td>Senior type</td> <td>11</td> </tr> <tr> <td>Middle type</td> <td>12</td> </tr> <tr> <td>Junior type</td> <td>21</td> </tr> </table>	Senior type	11	Middle type	12	Junior type	21	<p></p>
Senior type	11							
Middle type	12							
Junior type	21							

TABLE 14.3

## GINNERY INVENTORY : MACHINERY

LOCATION : KADUGLI

System	Method	Make	Type	Year	Serial Nr	Power	Comment
Power Supply	Direct Drive Diesel Engine via clutch and countershafts	Caterpillar 209 BHP	V8 Diesel D364	1957	19B319	156 KW	5.3/4" bore x 8" stroke 1000 RPM. Well maintained in good condition - spares still available
	Starter engine Clutch	Le Roi Caterpillar Caterpillar Skoda	D140 4 cyl. diesel Twin Disc 24154 Type D Battery Start 65-110	1957 1963 1957	19 x 7531 6F-5409 56B 2119 860 D32	75KW(100HP) 67KW (90HP)	Operation/condition good " " " " " " Only engine block remains cannibalised to service Skoda generator at NMC HQ Office
Transmission	Flat Belt (camel hair)		Eng. drive shaft 120 mm O/D Drive Pulley 500 mm O/D Countershaft Drive 86 mm O/D x 1500 long. Countershaft pulley 66 mm O/D Between shaft centres 4700 mm Centre drive shaft to G.L. 580/850 mm Centre driven shaft to G.L. 700 mm.			500 x 1000 666 = 750 RPM	Murray 90 Saw gin 70 RPM (12" Saw)
Seed Cotton Conveyance from Yard	Manual loading/unloading via contractors hand trucks.		No. 45 Fan	1957	N/A		Good condition
Conveyance within Ginnery	Manual feeding into pneumatic telescope via:- Airline cleaner Air Separator Conveyor Distributor Overflow Pen	Murray " " " "	4 cyl. with rock catcher Screw Conveyor Pneumatic telescope				" " " "

Feeding to Gin Stands	Extractor Feeders 4 off	Murray	Mitchell Super Unit	1957	49439 49440/7/8	Good condition
S/C Conditioning	Drying Oil F ired Boiler	Murray Murray	24 shelf tower drier	1963		Burner nozzle missing Poor condition - scrap
Humidification	Nil					
S/C Cleaning	Inclined Cleaner	Murray	7 cyl. x 72"	1957		Operation/condition good
Machine Picked S/C	Inclined Cleaner over Burr Machine	Murray	7 cyl. x 72" 14' long	1963 1963	HCI-1799-HB EB-695-HA	Good. Not in use piping disconnected "
Spindle Picker Only		Murray	No. 35 Fan	1963	N/A	
Gin Stands	Saw gins 4 off Saws 12" OD x 2.7/16" Bore x 264T (S.B.)	Murray	90x 12" OD Saw Air blast safety gins	1957	No.1 993/A No.2 993/A No.3 993/A no.4 993/A	Operation/condition good " " "
Cotton Seed Seed Conveying	Conveyor Rootes Blower via vacuum Wheel through blow pipe 5" OD	Murray Rootes	Screw Positive Displacement	1957 1957		" "
Seed Cleaning	Nil					
Seed Bagging	Manual from Heaps deposited on ground by blow system.					

TABLE 14.3 (cont.)

GINNERY INVENTORY : MACHINERY

LOCATION : KADUGLI

System	Method	Make	Type	Year	Serial Nr	Power	Comment
Seed Weighing	Platform Scale	Avery Auto Precision Dial	A 732/283 7.1/2cwt. 800 Rotls.	1957	B.33393/1		Uncovered
Trash Removal	From gin stands and Inclined Cleaner	Murray	No. 35 Fan	1957			Operation/condition good
Cotton Lint Lint Conveying	Via Air Blast Condenser	Murray	55" x 72"	1957			
Lint Cleaning	Saw Type	Constellation	Condenser (Series x 3) Single Saw (Series XLC-3)	1963	338760 348260		Condition Good. Not in use - by-passed "
	Trash Removal	Moss	Fan	1963			As Above
	Booster Air to Condenser		Fan V/A Fan				As Above As Above
Humidification	Lint Slide Statifier	Kemgas	Model OL.	1957	2050		Good condition but requires nozzles
Lint Baling	Oil hydraulic press Twin box manual rotating 55" x 20" Box Tramper	Murray	3 throw vertical ram pumps (2) Chain/gear drive fast and loose flat belt Manual brake	1957			Pumps in good condition Door locks good Tramper chain drive slack

Average bale weight 480 lbs.  
 Bale size 55 x 20 x 30/33  
 Standard Density 23/25 lbs/cu.ft.

Equipment	Description	Year	Comments
Lint Baling	Lint Feeder Door locks Manual	Murray "	Kicker hydraulic. Hand Pump. 3 locks per door
Lint Sampling	Platform Scale	Avery	3025 ABF 500 kg. 1100 Rotls.
Bale Weighing	Manual	1957	B.602168/2
Bale Conveying	Manual		
Lugata Recovery Processing	Manual As seed cotton through gins		
Water Supply	Deep bore well Engine and pump Drive by flat belt	Edico Recip Pump Numex	Fair condition - operational Average "
Fire Fighting	Fire tender with water tank Fire pump suction from tank and ground Reservoir	Commer/ Diesel Godiva 2 branch.	Good condition - fully operational Delivering water to housing estate.
Lighting	Li reshaft drive alternator Lighting set/diesel gen.	Stamford Lister Stamford	10 KVA 10 KVA 1500 RPM 415/240 volt Alternator

TABLE 13-1  
 TABLE 12-1

TABLE 15.1

GINNERY INVENTORY: BUILDINGS

LOCATION: TALODI GINNERY

Building	Description	Approximate dimensions L x W x H (m)	Comments
<b>Main Buildings</b> Ginning factory	Structure : steel framed, stanchions and trusses	39 x 16 x 6.5	In good condition, no remedial works required.
	Walls : GCI sheeting		
	Floor : concrete		
Mixing room	Structure : steel framed	19 x 8 x 4	In good condition, no remedial works required. The mixing room is a continuation of ginning factory building.
	Walls : 1 m brickwork		
	Floor : Concrete		
Store	Structure : load bearing brickwork	15 x 6 x 4	In good condition, no remedial works required. Mainly used for general agricultural purposes.
	Roof : GCI sheeting		
	Floor : Concrete		
Offices (3 Nr)	Structure : load bearing brickwork	16 x 9 x 4 14 x 9 x 4 5.5 x 5.5 x 4	In good condition, no remedial works required. Mainly occupied by agricultural staff.
	Roof : GCI sheeting		
	Floor : concrete		
<b>Other Buildings</b>	Brick and GCI roofing		In reasonable condition.
Weighing sheds			
Workshop			
Latrines			
Pump room			
Tractor shed			
Small stores			

TABLE 15.2

## GINNERY INVENTORY: INFRASTRUCTURE

LOCATION: TALODI

Facility	Description	Comments
<b>Water Supply</b> (a) Firefighting	Shallow well (as for domestic water) provides water for 10 000 gallon ground tank. Water is pumped by tender with hoses from ground tank. Portable fire extinguishers are provided within the factory.	
(b) Domestic and other uses	Shallow well provides water for 5 m high tank (1 500 gallons).	A shortage of water is experienced.
<b>Surface Water Drainage</b>	No special provisions.	No problems reported.
<b>Sewage Disposal</b>	Bucket latrines.	
<b>Roads/Access</b>	No surfaced roads to or within factory site.	
<b>Fencing</b>	Timber posts, tree branches, thatch, baling straps.	
<b>Platforms and Hardstandings</b>	None.	
<b>Houses</b>	<p>Senior type 1</p> <p>Middle type 2</p> <p>Junior type 8</p> <p>Constructed in brick with GCI roof and concrete floor. Sanitation by bucket latrines.</p>	House maintenance is poor. Most of the houses are occupied by agricultural staff, only 3 ginnery staff being housed. 1 further middle staff house is required for all middle staff to be housed.

TABLE 15.3

GINNERY INVENTORY ; MACHINERY

LOCATION: TALODI

System	Method	Make	Type	Year	Serial Nr	Power	Comment
<b>Power Supply</b>	Direct Drive diesel engine via clutch, countershafts. Flat and V Belts	Caterpillar	D.375 V8	1957	N/A	178 KW	Ok. Spares needed for overhaul. Fuel consumption. 6 galls. hr.
	Starting by compressor	Ruston	Single Cyl.		369441	250/350 RPM	
	Air Receiver	Crossley					
	Clutch Transmission	Caterpillar	Twin disc. 24154				Ex Lagowa ginnery (old plant)
<b>Engine Cooling</b>	From Sectional Steel tank elevated to 2m. on concrete piers. Panels 5 x 3 x 22 400 galls total 12000 galls. (54,500 litres)						
	Engine cooling water discharge gravitates through cooling tower over main tank.						
<b>Main Drive</b>	Flat belt, camel hair						
			Engine Drive Shaft 120 mm O/D				Lummus 90 saw gin 850 RPM
			Drive Pulley 470mm O/D				
			Countershaft 86 mm O/D				
			C/shaft Pulley 666mm O/D				Possible conversion of drive to vee belts to reduce slip
			Distance between shaft centres 4680mm				
			Centre Drive shaft to G.L. 470/850mm				
			Centre driven shaft to G.L. 700mm.				
<b>Seed Cotton</b>							
Conveying from storage	Manual loading on to Tractor drawn bogies	Ford	3m x 2m			65 HP	Up to 10 x 113 kg. sacks of s/c
			4 wheel bogey				

Conveyance within Ginnery

Hand fed into underfloor 2 point pneumatic system

1957

Double HF176 Fan

Lummus

Air separator

Conveyor Distributor  
Overflow pen - Manual

Nil

Operation/condition good

"  
"  
"

N/A  
CS6 - C - B

Seed Cotton Conditioning

S/C Cleaning

Inclined Cleaner Gravity  
Gin Feeders

Lummus

6 cyl, 72"

1957

Super Thermex Extractors

"

Nil

Operation/condition good

Gin Stands

Saw gins - 90 saw (282 teeth R.B. x 12" OD x 2.7/16" bore)

1957

Model G.I multi jet air blast  
Type C

Lummus

Under gin scroll conveyor  
Seed Blower  
Via vacuum wheel through 5" OD pipe to yard dump.

OK/Loose seed roll  
OK/Tight seed roll  
OK/Loose seed roll

Cotton Seed Conveying

Manual from heap deposited on ground from blowpipe system

1957

AF-Size 717

Lummus

Rootes

Good Condition  
Good Condition

Bagging

Investigate possibility of introducing bagging conveyors

СИМЕКА ИМЕЧЛОБА - ИВЧИНИКА

1957E T273 (cont.)

FOCUSION: 1M7001

GINNERY INVENTORY : MACHINERY

TABLE 15.3 (cont.)

LOCATION : TALODI

System	Method	Make	Type	Year	Serial Nr	Power	Comment
Trash Removal	Pneumatic from gin	Lummus	HF 176 Double fan	1957	N/A		Condition/operation good. One end of double fan is trash suction and also pulls from top end of thermex feeder. Other end acts as pull fan to front end of thermex drawing from atmosphere.
Cotton Lint Lint Conveying	Via air blast through lint flue	Lummus	HF 176 Double Fan	1957			Operation/Condition good. One side of double HF176 Fan - other side s/c suction.
Lint Baling	oil hydraulic, twin box manual rotating - up packing press	Lummus Single Ram (12" OD)	50" x 20" Standard Density	1957			Operation/condition good. Finished bale 51" x 21" x 31" 450 lbs. = 25 lbs. cu.ft. 7 Titan bale ties.
	Press Pump	Lummus Triple Ram horizontal	Speedex	1957			Good. Supposed to be replaced by AX-1 pump but this is low density only and is unsuitable.
	Tramper	Lummus Double Chain Guide Rod type		1957			Good, apart from the need to adjust guide rods to prevent contact with top frame.
	Lint Feeder	Lummus	Kicker Paddle	1957			
	Door Locks	Lummus	Hand Pump Hydraulic	1957			Operation/condition good
Lint Cleaning	Nil						

LOCATION/NO.	Description	Comments
Lugata	Manual	
Recovery	As s/c through gins	
Processing		
Water Supply	Shallow well (600m from factory)	Pumping to 1600 gall storage tank then to ground tank at ginnery.
Fire Fighting	Ground Reservoir	GPC5721192
	Edico Recip pump-Lister 6/1 Engine	Operation/condition good
	Godiva Electric	
	Start 4 cyl Petrol eng. P/P	
	Dennis Pump Unit - Mobile	Appears to have been abandoned in favour of Godiva P/P Exhaust manifold broken
Fuel Storage	12 Canvas/rubber hoses	
	8 Nuswift gas pressure water fire extinguishers	
	210 litre drums	
	Braithwaite tank	No longer in use
Lighting	Lineshaft generator voltage regulator	91851/5 4.5 KVA Operation/condition good
	Diesel generator	2337617 4.5KW(6HP) " "
	Stamford Alternator	R63045/10 4.5 KVA " " This replaced former Lister Alternator

TABLE 16.1

GINNERY INVENTORY: BUILDINGS

LOCATION: KOLOGI

Building	Description	Approximate dimensions L x W x H (m)	Comments
<b>Main Buildings</b>			
Ginning factory	Structure : steel framed, stanchions and trusses Walls : GCI sheeting Roof : GCI sheeting Floor : concrete	34 x 13 x 7	In good condition, no remedial works required.
Mixing room	Structure : steel framed, stanchions and trusses Walls : 1 m brickwork Roof : GCI sheeting Floor : Concrete	28 x 14 x 4	In good condition, except for floor which is badly cracked and needs to be replaced.
Stores	Structure : load bearing brickwork Roof : GCI sheeting Floor : Concrete	15 x 6 x 4	In good condition, no remedial works required. Mainly used for general agricultural purposes.
Offices (3 Nr)	Structure : load bearing brickwork Roof : GCI sheeting Floor : concrete	9 x 5 x 4 11 x 6 x 4 13 x 5.5 x 4	In good condition, no remedial works required. Mainly occupied by agricultural staff.
<b>Other Buildings</b>			
Weighing sheds	Brick wall and GCI sheeting	various	In reasonable condition.
Guard room			
Store			
Pump room			
Latrines			
Weighing rooms			

TABLE 16.2

## GINNERY INVENTORY:INFRASTRUCTURE

LOCATION:KOLOGI

Facility	Description	Comments
<b>Water Supply</b>		
(a) Firefighting	A 10 000 gallon ground tank is filled by tank taking water from the domestic well (see below) or from water 32 km away. Water is pumped (out of order) with hoses for yard fire-fighting. Extinguishers are provided for factory fire-fighting.	The provision of water is a constraint.
(b) Domestic and other uses	13 m deep well with 2 inch pump located 500 m away from factory. Water delivered to factory and houses by trailer tanker.	Supply is inadequate especially from March to June.
<b>Surface Water Drainage</b>	No special provisions.	No problems reported. Natural drainage takes place to west.
<b>Sewage Disposal</b>	Bucket latrines.	
<b>Roads/Access</b>	No surfaced roads to or within factory site.	
<b>Fencing</b>	Timber posts, tree branches and thatch.	
<b>Platforms and Hardstandings</b>	None.	
<b>Houses</b>	5 junior houses constructed in brick with GCI sheeting roofs and concrete floors. 1 mess of similar construction. 12 mud thatch houses for workers, sanitation by bucket latrine.	Houses were built in thirties and are in poor condition, require maintenance. 2 of the 5 junior houses are occupied by ginnery staff. 1 middle staff house is required to house ginnery staff.

TABLE 16.3

GINNERY INVENTORY : MACHINERY

LOCATION : KOLOGI

System	Method	Make	Type	Year	Serial Nr	Power	Comment
Power Supply	Direct drive diesel engine via clutch countershafts, flat and vee belt drives	Caterpillar V8. 8" stroke x 5.1/2" bore Caterpillar	D.364 1000 RPM Twin Disc	1955	19B 326 Bill of Material (156 KW) No 2L 3910	209 BHP	Good condition - spares needed for overhaul
	Clutch				Spec.No. 24514 No.6F-5409 19 x 11519		
	Starter Engine	Le Roi 4 cyl.	D.140				
Transmission	Flat Belt (Camel Hair)		Engine Drive Shaft 120 mm O/D Drive Pulley 500mm O/D Countershaft Drive 86mm O/D x 1500 long Countershaft Pulley 666mm O/D Between shaft centres 4700mm Centre Drive Shaft to G.L.580/850mm Centre Driven Shaft to G.L. 700mm.				
Seed Cotton	Manual loading into tractor drawn bogies	830x3000 4 wheel					
Conveyance from storage							Upto 10 x 113 KG sacks of 5/C

FOCVL110M:K01001

Conveyance Within Ginnery	1955	N/A	Condition/operation good
Hand Fed into underfloor suction pipe	Murray		
Pneumatic system	Murray	D.45 Fan	
Separator/vacuum wheel	Murray	72"	
Conveyor Distributor	"	16"	
Overflow Pen	"		
Nil			
Nil			
S/C Conditioning Drying	Murray Mitchell Super Units	No.1 49462 No.2 49458 No.3 49459 No.4 49455	Condition/operation good
S/C to Gin Stands	Murray		
Via Extractor Feeders			
Nil			
Nil			
S/C Cleaning	Murray		Condition/operation good
Inclined Cleaner - Gravity			
72" 7 cyl.			
Gin Stands	Murray	No.1 993.A.39 No.2 993.A.36 No.3 993.A.37 No.4 993.A.38	Condition/operation good Loose seed roll on all gin stands
Saw Gins 90 Saw 264 teeth x 12" OD x 2.7/16" bore			
Blast Fan	D.45		
Cotton Seed Seed Conveying	Murray Rootes	Af Size 717	Condition/operation good
Conveyor below gins to - Seed blower via vacuum wheel through blowpipe to yard pump			
C/S Cleaning			
Nil			

TABLE 16.3 (cont.)

GINNERY INVENTORY : MACHINERY

LOCATION : KOLOGI

System	Method	Make	Type	Year	Serial Nr	Power	Comment
C/S Bagging	Manual from heap deposited on ground by blowpipe system						
Lugata Recovery Processing	Manual As S/C Through gins						
Trash Removal	Pneumatic from gins feeders and inclined cleaners. Condenser exhausting to expansion room. Trash and suction fans to cyclone.	Murray	D.35 Fan	1955			Operation/condition good
Cotton Lint Lint Covneyign	Via air blast through lint flue	Murray					Good condition
Lint Cleaning	Nil						
Lint Condenser	Drum Type	Murray	55" x 72"				Operation/condition good
Humidification	Lint Slide spray	Kemgas					"
Lint Baling	Lint Feeder Tramper	Murray Murray Atlas	Kicker Paddle Chain and Gear Drive	1955 1955			55 x 20 x 31 7 straps 480 lbs (218 kg)
	Press Pumps 2. Bale Press - oil hydraulic Double Box manual rotating Door Locks	Murray Murray PCX Manual Hydraulic	Triple Ram vertical	1955 1955 1955 1955			Standard Density (24 lbs. cu.ft.)

Category	Description	Quantity	Unit	Remarks
Bale Conveying	Manual			
Water Supply	Shallow well			Only 1 metre water in well
	Khaffir 32 kms distant			Water tanked in for engine cooling
Fire Fighting	Petrol Engine Pump from ground reservoir	FW 400.2/7919		Unable to start when requested
	18 lengths canvas hose	FWP 4003		
Lighting	Lineshaft Generator	74435/1	5 KVA	
	Voltage Regulator	91851/1		
	Lighting Set	2338617	6 HP (4KW)	
	Giu Sen Man 6 (Chinese)	5402-9	3 KVA	This alternator has replaced original Lister unit
Engine Cooling	Reservoir and cooling tower			20 x 400 = 8000 galls. (36000 litres)
		Braithwaite	5 x 2 x 2 Panels	

TABLE 17.1

GINNERY INVENTORY: BUILDINGS

LOCATION: ABU GEBEIHA

Building	Description	Approximate dimensions L x W x H (m)	Comments
<b>Main Buildings</b>			
Ginning factory	Structure : steel portals Walls : 1.6 m blockwork and asbestos sheeting Roof : asbestos cement sheeting Floor : concrete	30 x 13 x 6.6	About 10% of cladding and roofing needs replacing.
Store	Structure : steel framed, stanchions and trusses Walls : GCI sheeting Roof : GCI sheeting Floor : Concrete	29 x 15 x 4	In good condition, no remedial works required. The building originally housed the ginning factory. Mainly used for general agricultural purposes.
Offices (3 Nr)	Structure : load bearing brickwork Roof : GCI sheeting Floor : Concrete tiles	17 x 5 x 4 14 x 5 x 4 10 x 8.5 x 4	In good condition, no remedial works required. Mainly occupied by general agricultural staff.
<b>Other Buildings</b>			
Stores (2 Nr)			
Gate rooms (2 Nr)	Brick and GCI sheeting	various	Reasonable condition.
Mech. sup. room			
Firefighting office			
Weighing rooms			
Wireless room			
Latrines			

GINNERY INVENTORY:INFRASTRUCTURE

LOCATION:ABU GEBEIIHA

Facility	Description	Comments						
<p><b>Water Supply</b> (a) Firefighting</p>	<p>From domestic well (see below) supplemented by neighbouring government well to 10 000 gallon brickwork ground tank. Water is pumped (with hoses) from the ground tank for yard firefighting. Four extinguishers are provided for the factory.</p>	<p>Ground tank leaks and needs to be reconstructed.</p>						
<p>(b) Domestic and other uses</p>	<p>13.5 m deep well pumped to 4 m high tank (1 400 gallons) and distributed by galvanised steel pipes.</p>	<p>No problems reported.</p>						
<p><b>Surface Water Drainage</b></p>	<p>No special provisions.</p>	<p>No problems reported.</p>						
<p><b>Sewage Disposal</b></p>	<p>Bucket latrines.</p>							
<p><b>Roads/Access</b></p>	<p>No surfaced roads to or within factory site.</p>							
<p><b>Fencing</b></p>	<p>Timber posts, tree branches and thatch.</p>							
<p><b>Platforms and Hardstandings</b></p>	<p>None.</p>							
<p><b>Houses</b></p>	<table border="0"> <tr> <td>Senior type</td> <td>1</td> </tr> <tr> <td>Middle type</td> <td>2</td> </tr> <tr> <td>Lower type</td> <td>10</td> </tr> </table>	Senior type	1	Middle type	2	Lower type	10	<p>In good condition. Agricultural staff occupy 11 houses and ginneries staff occupy 2 houses. 2 further middle staff houses are required for ginneries staff.</p>
Senior type	1							
Middle type	2							
Lower type	10							
	<p>Constructed in brick with GCI sheeting roof and concrete tile floors. Bucket latrines.</p>							

TABLE 17.3

GINNERY INVENTORY : MACHINERY

LOCATION : ABU GEBEIIHA

System	Method	Make	Type	Year	Serial Nr	Power	Comment
Power Supply	Direct drive diesel engine via clutch, countershafts, flat and V Belt Drives	Ruston	Size 4 Class BEB 500 RPM	1954	371575	240 HP (180 KW)	Condition good Exhaust temps. No. 1 290°C
	Oil Cooler	Serck	Tube Stack		58867		2 300°C
	Air Filter	Visco			15531		3 300°C
	Fuel Pumps	Engineering			List No.RPC1600B		4 310°C
	Clutch	Wigglesworth					Cyl. Temps.
	Air Start Compressor	Ruston (2 off)	Size 3" x 3.1/2" 250/350 RPM		378321/2		No. 1 110°F 2 115°F 3 115°F 4 Broken
Main Transmission	Vee Belt (13 x "C")						
Lighting	Line shaft alternator	Workman Reed & Co.	230/400V	1954	41291	7 KVA	Condition Good
	Lighting set - engine	Armstrong Siddley	ASJI 1500 RPM		659/ASJI	8.5HP	Governor problem
	Alternator	Stamford	HS 8L		R65549/4	5 KVA	
	Voltage regulator	Arthur Lyon	3HS 8/10		90670/4		
Seed Cotton							
Conveying from	Manual loading on to tractor drawn bogies	4 wheel	3m x 2m				Up to 10 x 113 KG sacks of S/C
Conveying within ginnery	Hand fed into underfloor 3 point suction system.						
	Pneumatic system	Murray	MF.45 Fan VS 2794A	1954			Condition good
	Air Separator						"
	Conveyor Distributor						"
	Overflow pen - manual						"

S/C Cleaning	Inclined Cleaner - gravity	Murray	7 cylinder 72" wide	1954	HCI 1052A	Condition good
S/C Drying	Nil					
S/C Humidification	Nil					
S/C to gin stands	Via extractor feeders	Mitchell Super units		1954	No.1 47867 47866 47869 47868	Condition/operation good
Gin Stands 4	Saw gins 90 saw 264 teeth x 12" OD x 2.7/16" bore S.B.	Murray	Air blast MF45 Fan			This model gin is of the type prior to the 90 saw safety gin. Otherwise identical.
Cotton Seed Conveying	Under gin scroll conveyor to Seed blower via vacuum wheel through blow pipe to yard pump	Murray Rootes	RAI-58 AVM Size 615	1954		
Cleaning	Nil					
Bagging	Manual from heap deposited on ground from blowpipe system					
Lugatta Recovery	Manual					Lint recovered is termed "SCARTO"
Processing	As s/c through gins					

## GINNERY INVENTORY : MACHINERY

TABLE 17.3 (cont.)

LOCATION : ABU GEBEIIHA

System	Method	Make	Type	Year	Serial Nr	Power	Comment
Trash Removal	Pneumatic from gin feeders and inclined cleaners. Condenser exhausting to expansion room trash and suction fans to cyclones.	Murray	MF35 Fan	1954			Condition good
Cotton Lint							
Lint Conveying	Via air blast through lint flue	Murray					Condition good
Lint Cleaning	Nil						
Lint Condenser	Drum Type	Murray	55" x 72"				Condition good
Lint Humidification	Lint slide spray		Kemgas, statifier				
Lint Baling	Lint Feeder Tramper	Murray Murray/ Atlas	Kicker paddle 48" long stroke				
Bale Conveying	Press Pumps Bale press - oil hydraulic Manual rotating double box up-packing. Door locks	Murray Murray	2 vertical triplex pumps 1937 model PCS	1954	HY 5120-A		Condition/operation good Bale size 55 x 20 x 31 7 straps 480 lbs. standard density Condition/operation good
Engine Cooling	Reservoir and cooling tower	Braithwaite	Panels 6 x 2 x 2	1954			14 x 400 = 9600 galls (42750 litres)

Fire Fighting Facility	Petrol engine pump from small ground reservoir	Godiva	Electric start	Condition/operation good
		Dennis	Trailer/tender	Abandoned but looks intact
<b>Water Source</b>	Shallow well, engine driven pump	Numex (Indian)	6/1 Nelt	Drives by flat belt. A pump located within the well is inaccessible.
<b>Fuel Storage</b>	210 litre drums bulk	Braithwaite	3 x 2 x 2	12 x 400 = 4800 gallons = (21000 litres)

1907E 187

TABLE 18.1

LOCATION: UMM BEREMBEITA

GINNERY INVENTORY: BUILDINGS

Building	Description	Approximate dimensions L x W x H (m)	Comments
<b>Main Buildings</b> Ginning factory	Structure : steel framed, stanchions and trusses	35 x 21 x 7	In good condition, no remedial works required.
	Walls : GCI sheeting		
	Roof : GCI sheeting Floor : concrete		
Main store	Structure : load bearing brickwork	17 x 8 x 4.5	In good condition, no remedial works required. Mainly used for general agricultural purposes.
	Roof : GCI sheeting		
	Floor : concrete		
Offices (3 Nr)	Structure : load bearing brickwork	5.5 x 4 x 4 10.9 x 5.6 x 4 4.8 x 4.8 x 4	In good condition, no remedial works required. Mainly occupied by agricultural staff.
	Roof : GCI sheeting		
	Floor : concrete		
<b>Other Buildings</b> Co-operative shop Weighting sheds Fuel store	Bricks and GCI sheeting. Thin tin sheets for store.	various	In good condition.

## GINNERY INVENTORY:INFRASTRUCTURE

LOCATION: UMM BEREMBEITA

Facility	Description	Comments
<b>Water Supply</b>		
(a) Firefighting	Same source as domestic supply. Water is pumped by hand pump to 10 000 gallon ground tank. Water is pumped (by diesel pump) from ground tank to hoses for yard fire-fighting. Four extinguishers are provided for the factory.	Existing diesel pump needs replacing.
(b) Domestic and other uses	Hand operated pump pumps water from 12 m deep well to standpipe whence water is transported by tanker to houses.	
<b>Surface Water Drainage</b>	No special provisions.	No problems reported.
<b>Sewage Disposal</b>	Bucket latrines.	
<b>Roads/Access</b>	No surfaced roads to or within ginnery site.	
<b>Fencing</b>	Timber posts, tree branches and thatch.	
<b>Platforms and Hardstandings</b>	None.	
<b>Houses</b>	<p>Junior type 5</p> <p>Rest house 1</p> <p>Constructed in brick with GCI sheeting roof and concrete floor.</p>	Houses occupied by agricultural staff except for 1 Nr junior staff house which is occupied by ginnery employee. 1 further middle staff house is required for ginnery staff.

TABLE 18.3

GINNERY INVENTORY : MACHINERY

LOCATION : UMM BEREMBEITA

System	Method	Make	Type	Year	Serial Nr	Power	Comment
Power Supply	Gas producer from cotton seed	Ruston			6005		
	Gas engine driving through clutch, countershaft, flat and V belt drives Clutch	Ruston	Size 12 Class GRD		171583	120 HP 236 RPM	
	Starting Compressor (2)	Wigglesworth Ruston	24 DS Size 3" x 3.1/2"		378323/4		
Main Drive Transmission	Direct Through clutch to lineshaft						
Lighting	Lighting set	Lister	6/1		246451/R		
		Stamford Alternator	H5.8L		R63045/4	4.5 KVA	
Engine Cooling	Overhead tank with auxiliary cooling through small recirculating pumps through cooling tower over tank		Sectional panels 3 x 3 x 3				27 x 400 = 10800 galls.
Seed Cotton Conveying from storage	Manual loading on to tractor drawn bogies		4 wheel bogie 3m x 2m				Up to 10 x 113 KG sacks seed cotton.
Conveying in ginnery	Hand fed into 3 point underfloor suction system. Pneumatic system	Platt/ Murray					Condition good Existing ginnery hand usage Fan No.95594 Works No.66883
		Davidson Scirocco					

Conveying in ginnery	Air Separator/Conveyor	Platt/Murray	Canvas Valves and S/C Droppers	Condition/operation good
Cleaning	Extractor Feeder only			
Drying	Nil			
Humidification	Compressed air and water	Mather & Platt	Vortex	Obsolete - out of use due to lack of rings for the compressor
Feeding to Gins	Via Extractor feeders	Mitchell Super Units		
Gin Stands 4	Saw gins - 80 saw with huller front	Platt/Murray		
	Air blast	Davidson Scirocco		
Trash Removal	Pneumatic from extractors exhausting to cyclone	Murray	MF.30 Fan	Gin stand moting by underfloor scroll to bagging point.
Cotton Lint Lint Conveying	Via air blast through lint flue			

M/C No.6088  
 Symbol SA6  
 Cyl. 6" x 7"  
 RPM 420 at  
 100 lbs. sq"  
 No.1 49429  
 49428  
 49430  
 49431  
 Frame Nos.  
 A.1516  
 A.1543  
 Fan No. 95593

TABLE 18.3 (cont.)

GINNERY INVENTORY : MACHINERY

LOCATION : UMM BEREMBEITA

System	Method	Make	Type	Year	Serial Nr	Power	Comment
Lint Cleaning	Nil						
Lint Humidification	Nil						
Lint Condenser	Drum Type Exhaust to atmosphere through roof	Platt Murray	60"				Old type
Lint Baling	Lint feeding - manual pushed down very short lint slide with sticks through slots. Tramper - mechanical rack and pinion Press pumps - water hydraulic	John Shaw John Shaw	Church type 3 throw vertical				2 x LP x 3.3/4" OD 1 x HP x 1.7/16 OD  Box size 25 x 39 x 25 6 band 380 lbs. 26 lbs.cu.ft. Excessive leaks at control block Baling time 15 mins.
Bale Conveying	Bale press - water hydraulic manual rotating double box. Control block Door locks	John Shaw	310 ton "C" type mechanical		2854		
Bale Conveying	Manual	mechanical					
Colton Seed C/S Conveying	Under gin scroll to transverse scroll inclined to gas plant feeding platform. Excess to rail dump trucks to open area some distance away						Should be bagged immediately outside gin but any mods. likely to be superceded by complete replacement of plant.

C/S Cleaning  
C/S Bagging

Manual from heaps deposited from dump trucks.

Lugatta Recovery Process

Manual As s/c

Fire Fighting

Petrol engine 2 branch  
Pump  
Small ground tank  
10 hose reels (Canvas/rubber)  
10 extinguishers

Water Supply

210 litre drums

Fuel Storage

210 litre drums

Fencing

Barbed wire

Platforms and

None

Houses

Senior type  
Middle type  
Decomposed type

10/11

Constructed in brickwork. Senior houses have GCI roof, others earth floor. Senior and middle type houses have concrete floor, junior houses have earth floor. Bucket latrines.

10/11

10/11

10/11

Description

Water supply: concrete  
Firefighting: Source: 1000 litre reservoir 2 km from site. Water is pumped to 6 ft high (specification) tank at reservoir and flows by gravity (flexible) to factory. Water is pumped into 1000 x 1000 x 1000 tank for the factory.  
Extinguishers: 10

Coventry Climax Godiva  
Water carried by tanker from standpipes  
10 x 10 x 10  
12 x 8 x 4

10 x 10 x 10

12 x 8 x 4

22 x 11 x 9

10 x 10 x 10 (w)  
10 x 10 x 10  
10 x 10 x 10

Constructed in brickwork. Senior houses have GCI roof, others earth floor. Senior and middle type houses have concrete floor, junior houses have earth floor. Bucket latrines.

10/11

10/11

Comments

There is a small area located at the end of road of pipe emitting emission plume  
Hose reels on gin platform, 3" main to 4 hydrants supplied from overhead tank

10748  
FWMP 872

No water treatment.  
No problems reported. Natural drainage takes place to south and east.

10/11

10/11

10/11

10/11

Houses are mainly occupied by agricultural staff. 3 houses are occupied by primary staff. 1 further middle staff house is required to house primary staff.

10/11

## GINNERY INVENTORY:BUILDINGS

LOCATION:SEMEIH

TABLE 19.1

Building	Description	Approximate dimensions L x W x H (m)	Comments
<b>Main Buildings</b> Ginning factory	Structure : steel framed, pipe trusses and stanchions Walls : asbestos cement sheeting Roof : asbestos cement sheeting Floor : concrete	35 x 17 x 6	Some heave of floors has taken place but no remedial works are required. Whole of roof sheeting and 25% of wall sheeting needs replacing.
Store	Construction as ginning factory	35 x 17 x 6	In good condition, no remedial works required.
Mixing room	Structure : steel framed Walls : 1 m brickwork Roof : GCI sheeting Floor : concrete	15 x 8 x 4	In good condition, no remedial works required.
Office	Structure : load bearing brickwork Roof : GCI sheeting Floor : concrete tiles	4 x 4 x 4	In good condition, no remedial works required.
Main stores (2 Nr)	Structure : steel framed stanchions and trusses Walls : GCI sheeting Roof : GCI sheeting Floor : concrete	100 x 40 x 7	In good condition, no remedial works required. Not on ginnery site but located about 200 m from factory on railway siding. Used for storage of bales awaiting evacuation by rail. There is a similar store located at the railhead at Debeibat.
<b>Other Buildings</b> Firefighting office Store Classifier room (abandoned) Latrine	Brick and GCI sheeting.	various	Reasonable condition.

TABLE 19.2

GINNERY INVENTORY: INFRASTRUCTURE

LOCATION: SEMEIH

Facility	Description	Comments
<b>Water Supply</b> (a) Firefighting	Source is surface reservoir 2 km from site. Water is pumped to 6 m high (4 500 gallon) tank at reservoir and flows by gravity (4 inch pipe) to factory. Water is pumped with hoses from standpipe for yard firefighting. Extinguishers are provided for the factory.	
(b) Domestic and other uses	Same source as above. Water is carried by tanker from standpipe to houses.	No water treatment.
<b>Surface Water Drainage</b>	No special provisions.	No problems reported. Natural drainage takes place to south and east.
<b>Sewage Disposal</b>	Bucket latrines.	
<b>Roads/Access</b>	No surfaced roads to or within ginnery site. Sudan Railways sidings to main stores.	
<b>Fencing</b>	Barbed wire and steel angle posts.	Incomplete on eastern side.
<b>Platforms and Hardstandings</b>	None.	
<b>Houses</b>	<p>Senior type 3</p> <p>Middle type 5</p> <p>Junior type 9</p> <p>Constructed in brickwork. Senior houses have GCI roof, others are thatched. Senior and middle type houses have concrete floor, junior houses have earth floor. Bucket latrines.</p>	<p>Houses are mainly occupied by agricultural staff.</p> <p>3 houses are occupied by ginnery staff. 1 further middle staff house is required to house ginnery staff.</p>

TABLE 19.3

LOCATION : SEMEIH

GINNERY INVENTORY : MACHINERY

System	Method	Make	Type	Year	Serial Nr	Power	Comment
Power Supply	Direct drive diesel engine via clutch	Ruston	Size 4 Class VEB 500 RPM		371574		Exhaust temperatures 440, 480, 480, 465
	Clutch	Wigglesworth No. 2					
	Air Compressor	Ruston	Twin 3" x 3.1/2"		DC 107		
Lighting	Generating Set	Lister	Single cyl. petrol 18D2T		29838	1 KVA	
	Lineshaft Generator	Stamford	HS 11 1500 RPM			10 KVA	
Seed Cotton							
S/c Conveying	Pneumatic telescope	Davidson			Fan No. 112949		Fan out of balance
S/C Conveying in Ginnery	Canvas valve droppers	Scitroco			Works No. 92751		
S/c Cleaning	Extractor Feeders (4)	Mitchell	Super Unit		49432 49433 49434 49435		Condition good
S/c Drying	Nil						
S/c Humidification	Nil						
Trash Removal	From extractor feeders to twin cyclones	Murray	MF 303				Cast iron type
Gin Stands	Saw Gins (4)	Platt/ Murray	80 saw				poor condition
		Air Blast Davidson Scitroco	Huller Fronts				

**Cotton Lint**

Lint Cleaning  
Lint Condenser

Nil

Platt  
60" OD  
1926 model

Lint Humidification

Lint slide statifer

Kemgas  
Model CL

Lint Baling

Oil hydraulic

Platt/  
Lummus  
Double Box Rotating  
Up Packing Mechanical  
Tramper

1966

Press pump

Lummus/  
Dennison

M.P.T.U.

30033/10710  
No.3

20" x 40" Bale - 360/410 lbs.  
9 straps pressure gauge not  
working. Dump valve not  
operating satisfactorily. Operator  
not releasing pressure before  
"jogging" pressing cycle - 4 mins  
-15 B.P.H. Pump couplings U/S

Lint Sampling  
Bale Weighing  
Bale Conveying

Manual  
Platform scale  
Manual

Avery

3205 ABF 500 KG

B-52941-5

**Cotton Seed**

C/S Conveying

Scroll conveyor  
Below gin stands  
Seed Blower

Holmes  
Huddersfield

6" x 15"

RBS Blower 5 lbs. sq."

7438

C/S Bagging

Manual from heap deposited on ground  
below blow pipe.

TABLE 19.3 (cont.)

GINNERY INVENTORY : MACHINERY

LOCATION : SEMEIH

System	Method	Make	Type	Year	Serial Nr	Power	Comment
Lugatta Recovery Processing	Manual Through gins as s/c	Commer Godiva Coventry Climax	Size 4 Class VSB 200 HP Single cyl. piston motor % x 12h Single cyl. piston motor				1000 gall water tank
Fire fighting	Fire tender with pump		100 ft 1000 RPM 2500 VSB 200 HP				
Water Supply	From distant ground reservoir via 3" main						Condition good
S/o Cleaning							
S/o Cleaning							
S/o Cleaning							
Tresh Removal	From extractor feeders to twin cyclones						
Tresh Coumpuset							
Chaffing							

Comments	Description	Comments
Supply frequently cut. A 14 m deep well is situated in the factory site but lacks a pump. Pump needs replacement. Supply is frequently cut.	Municipal supply to 10 000 gallon ground tank. Water is pumped by diesel pump with hoses from ground tank for yard for firefighting. Extinguishers are provided in the factory.	
	Brick and GCI apartment - Municipal supply.	
	<p>Surface Water Drainage Office</p> <p>Structure : 1000 parking structure</p> <p>78 x 3 x 0 32 x 3 x 0</p>	
	<p>Sewage Disposal Roof/Access Store</p> <p>Brick and GCI apartment - Municipal supply.</p>	
	<p>Firefighting Manufacture and Metal Building</p> <p>Structure : steel frame, steel joist sub 1 - Steel frame in building tower 2 - 10000 sq ft approx adjacent to factory 3 - 10000 sq ft approx adjacent to factory</p> <p>32 x 31 x 3</p>	
	<p>Building</p> <p>Structure : steel frame, steel joist sub 1 - Steel frame in building tower 2 - 10000 sq ft approx adjacent to factory 3 - 10000 sq ft approx adjacent to factory</p> <p>7 x W x H (in) approximate dimensions</p>	

GENERAL INFORMATION

PLATE 507

LOCATION: DALLAS

TABLE 20.1

GINNERY INVENTORY: BUILDINGS

LOCATION: DILLING

Building	Description	Approximate dimensions L x W x H (m)	Comments
<b>Main Buildings</b> Ginning factory	Structure : steel framed, stanchions and trusses Walls : GCI sheeting Roof : GCI sheeting Floor : concrete	35 x 21 x 7	In good condition, no remedial works required.
Store	Structure : steel framed Walls : GCI sheeting Roof : GCI sheeting Floor : concrete	16 x 8 x 4	In good condition, no remedial works required (same design as for factory).
Offices	Structure : load bearing brickwork Roof : GCI sheeting Floor : concrete tiles	15 x 7 x 4 18 x 7 x 4	In good condition, no remedial works required.
<b>Other Buildings</b> Co-operative shop Mech. Sup. office Fuel store Weighing rooms Latrines Ablution block Generator room	Brick and GCI sheeting.	various	Reasonable condition.

TABLE 20.2

GINNERY INVENTORY: INFRASTRUCTURE

LOCATION: DILLING

Comments

Description

**Water Supply**  
(a) Firefighting

Municipal supply to 10 000 gallon ground tank. Water is pumped by diesel pump with hoses from ground tank for yard for firefighting. Extinguishers are provided in the factory.

(b) Domestic and other uses

Municipal supply.

**Surface Water Drainage**

No special provisions.

Natural drainage takes place to Khor Abu Habil which runs along the boundary of the site.

**Sewage Disposal**

Bucket latrines.

**Roads/Access**

No surfaced roads within factory site. Site is adjacent to black top Kadugli/Debeibat road.

**Fencing**

Timber posts, tree branches and thatch

**Platforms and Hardstandings**

None

**Houses**

- 1 Senior staff house in Dilling town
- 1 Rest house in Dilling town
- 2 Middle staff houses adjacent to factory
- 5 Junior staff houses adjacent to factory

Houses are mainly occupied by agricultural staff. Only 3 houses are occupied by ginner staff.

TABLE 20.3

LOCATION : DILLING

GINNERY INVENTORY : MACHINERY

System	Method	Make	Type	Year	Serial Nr	Power	Comment
Power Supply	Direct Drive Diesel	Ruston	Size 5 Class VCBX		446396	255 HP	Exhaust Temps. 280°C
	Clutch	5 cyl T/C	600 RPM				280°C
	Starting Compressor	Wigglesworth			54869	2.5 HP	300°C
		Ruston Engine WD8			466411		315°C
		" Compressor 3" x 3.1/2"					270°C
							Turbocharger thermometer required. Negretti and Zambra 90-0-1200°F
Main Drive	Direct through clutch to lineshaft						
Transmission							
Lighting	Lighting set	Lister 6/1 Stamford Alternator	HS8L		CS 69429 R63045/S S0344/5	6 HP 4.5 KVA	
Engine Cooling	Overhead tank with auxiliary cooling through small recirculating pump through cooling tower over tank.	Braithwaite Type	3 x 3 x 3				27 x 400 = 10800 galls (48000 litres)
Seed Cotton	Manual loading on to tractor drawn bogies	4 wheel	3m x 2m				Up to 10 x 113 KG sacks s/c
s/c Conveying in Ginnery	Hand fed into underfloor 3 point suction system. Pneumatic system	Platt/ Murray Davidson Scirocco	Size 20				Condition good

Function	Equipment	Manufacturer	Year	Notes
Air Separator/Conveyor	Platt/ Murray	Canvas valve S/c Droppers		
s/c cleaning	Nil (Extractor feeders only)			
s/c Drying	Nil			
s/c Humidification	Mather & Platt	Vortex	1929	Obsolete - out of use due to lack of rings for compressor
S/c Feeding to Gins	Frank Peart & Co.	3 Ram Pump		
	Mitchell Super Units			No. 1 49427 2 49424 3 49454 4 49453
Gin Stands 4	Platt/ Murray Davidson Sciocco	Air blast Fan Size 16		Frame Nos. 112951 W. No. 32751
Trash Removal	Murray	MF.30 Fan		Gin stand moting by underfloor scroll to bagging point.
Cotton Lint Lint Conveying				

TABLE 20.3 (cont.)

GINNERY INVENTORY : MACHINERY

LOCATION : DILLING

System	Method	Make	Type	Year	Serial Nr	Power	Comment
Lint Cleaning	Nil						
Lint Humidification	Nil						
Lint Condenser	Drum type exhaust to Atmosphere through roof.	Platt/	60"				Old type
Lint Baling	Lint feeding - manual pushed down very short lint slide with sticks through slots. Tramper - mechanical Rack and Pinion. Press pumps Water hydraulic	John Shaw	Church Arch 4 throw vertical 2 x LP 2 x HP 310 ton				Box size 25" x 39" x 25" 6 band 350 lbs = 26 lbs cu.ft. Excessive leaks at control block Baling time 15 mins.
Bale Conveying	Bale Press - Manual Rotating double box Control Block Door locks	John Shaw	C.12 Mechanical		14/1056		
Cotton Seed c/s Conveying	Under gin scroll to transverse scroll inclined to gas plant feeding platform - excess to rail dump trucks to open area some distance away.						Should be bagged immediately outside gin, but any mods. likely to be superceeded by complete replacement of plant.

TABLE 21-2

LOCATION: LAGOWA

Facility	Description	Comments
C/s Cleaning C/s Bagging	Manual from heaps deposited from dump trucks.	
<b>Lugatta</b>		
Recovery Processing	Manual As s/c	
<b>Fire Fighting</b>	Petrol engine 2 branch pump, small ground tank 20 Hose reels (canvas/rubber) 10 Extinguishers	Chassis No. 7283TP3 Eng. No. 159631E189 Pump No. 7939 PF1 Hose reels on gin platform 3" main to 4 hydrants from overhead tank
<b>Water Supply</b>	210 litre drums	
<b>Fuel Storage</b>	58 x 14 x 4	
<b>Fencing</b>	Timber posts, wire branches and thatch	
<b>Platforms and Hardstandings</b>	None	
<b>Buildings</b>	Junior staff houses 8 Rest house 1	40 x 15' 2 x 2' 2 7 x 11 x 11 (w) quadrangle Vibroxquare
<b>Buildings</b>	Constructed in brick with GCI roofs and concrete floor. Bucket latrines.	Comments

1987E 3171

LOCATION: LAGOWA

TABLE 21.1

GINNERY INVENTORY: BUILDINGS

Building	Description	Approximate dimensions L x W x H (m)	Comments
<b>Main Buildings</b> Ginning factory	Structure : steel framed, trusses and stanchions Walls : 1.6 m blockwork and asbestos cement sheeting Roof : asbestos cement sheeting Floor : concrete	40 x 12.5 x 6.5	In good condition, no remedial works required.
Mixing room	Structure : steel framed Walls : 1.2 m brickwork Roof : GCI sheeting Floor : concrete	28 x 14 x 4	Structure is in poor condition with excessive deflection of roof trusses. Whole roof structure needs replacement.
Offices 4 Nr	Structure : loadbearing brickwork Roof : GCI sheeting Floor : concrete	9 x 7 x 4 8 x 7 x 4 11 x 10 x 4 20 x 5 x 4	In good condition, no remedial works required. Mainly occupied by agricultural staff.
Store	Structure : steel framed Walls : GCI sheeting Roof : GCI sheeting Floor : concrete	15.5 x 6 x 4	In good condition, no remedial works required. Also used for general agricultural purposes. Was originally built to house ginning factory.
Old ginning factory	Structure : steel framed Wall : GCI sheeting Roof : GCI sheeting Floor : concrete	44 x 16 x 6.5	In good condition, used as a general store.
<b>Other Buildings</b> Cooperative shop Plant protection office Latrines Ablution block	Brick walls and GCI sheeting	various	Reasonable condition.

TABLE 21.2

LOCATION: LAGOWA

GINNERY INVENTORY: INFRASTRUCTURE

Facility	Description	Comments
<p><b>Water Supply</b> (a) Firefighting</p>	<p>Same source as domestic supply plus a ground tank (11 000 gallons). Water is pumped by diesel pump with hoses from the ground tank for yard firefighting. Fire extinguishers are provided in factory.</p>	
(b) Domestic and other uses	<p>Water is supplied from a government deep well. 4 hours supply per day is allocated to the ginnery and housing area. Supply is pumped to 5 m high tank (11 000 gallons).</p>	<p>No problems are reported.</p>
Surface Water Drainage	<p>No special provisions.</p>	<p>Some flooding occurs in depression in southern part of site.</p>
Sewage Disposal	<p>Bucket latrines.</p>	
Roads/Access	<p>No surfaced roads to or within ginnery site.</p>	
Fencing	<p>Timber posts, tree branches and thatch</p>	
Platforms and Hardstandings	<p>None</p>	
Houses	<p>Middle staff houses 2 Junior staff houses 8 Rest house 1</p>	<p>In reasonable condition. Three of the houses are occupied by ginnery staff.</p>
	<p>Constructed in brick with GCI roofs and concrete floor. Bucket latrines.</p>	

## GINNERY INVENTORY : MACHINERY

LOCATION : LAGOWA

TABLE 21.3

System	Method	Make	Type	Year	Serial Nr	Power	Comment
Power Supply	Direct drive diesel engine via clutch countershafts, flat and V belt drives	Ruston	4 cyl. Size 4 Class VEB 500 RPM	1954	376964	240 HP (180 KW)	Exhaust temps. No. 1 290°C No. 2 300°C No.3 300°C No. 4 310°C
	Oil cooler	Serck	Tube Stack		61828		
	Air Filter	Visco			15531		
	Clutch	Engineering Wigglesworth					Cylinder Temps. No. 1 110°F No. 2 115°F No. 3 115°F No. 4 Broken
Main Drive Transmission	Air Start Compressor (2)	Ruston	Size 3" x 3.1/2" 250/350 RPM		378301/2(Not in use)		Condition/operation good
	Vee Belt		13 x "C"				
Lithing	Lineshaft Alternator	Gir Sen Electrical (China)	72 SA-5 1000 RPM	1954	540/38	5 KVA	"
	Lighting Set - Engine	Armstrong Siddley	ASJ.1 1500 RPM		663 ASII	8.5 B.H.P.	Faulty Governor
Engine Cooling	Alternator Voltage Reg.	Stamford Arthur Lyon	HSL 3HS 8/10		R655 49/5	5 KVA	
	Reservoir and cooling tower	Braithwaite	Panels 6' x 2' x 2'				14 x 400 = 9600 galls (42750 litres)
Seed Cotton Conveyance from Storage	Manual loading on to tractor drawn bogies	4 wheel bogies	3m x 2m				Up to 10 x 113 kg sackss/c

Conveyance within ginnery	Hand fed into underfloor 3 point suction system. Pneumatic system air separator Conveyor Distributor Overflow pen - manual	Murray "	M45 Fan	1954	VS 2794-D	Condition good
s/c Cleaning	Inclined Cleaner - gravity	"	7 cyl. x 72"	1954		
s/c Drying	Nil					
s/c Humidification	Nil					
s/c Feeding to gin stands	Via extractor/feeders	Mitchell	Super Units	1954	No. 1 47678 2 47871 3 47874 4 47870	This model gin is of the type immediately prior to the 90 saw (safety gin) otherwise identical
Gin Stands 4	Saw gins - 90 saw 264 teeth x 12" OD x 2.7/16" bore S.B.	Murray	Air blast MF.45 Fan			
Cotton Seed C/S Conveying	Under gin scroll conveyor to Seed blower via vacuum wheel through blow pipe to yard dump	Murray Rootes	RA1-58 AVM Size 615	1954	6189-V-4	Condition/operation good
C/S Cleaning	Nil					
C/S Bagging	Manual from heap deposited on ground from blow pipe system					

GINNERY INVENTORY : MACHINERY

LOCATION : LAGOWA

TABLE 21.3 (cont.)

System	Method	Make	Type	Year	Serial Nr	Power	Comment
Trash Removal	Pneumatic from gins feeders and inclined cleaner. Condenser exhaust to expansion room trash and suction fans to cyclones.	Murray	MF-35 Fan	1954			Condition good
Cotton Lint Lint Conveying	Via air blast through lint flue	Murray	As gin blast fan				Condition good
Lint Cleaning	Nil						
Lint Condenser	Drum Type	Murray	55" x 72"		TC 1791A		
Lint Humidification	Lint slide spray	Kemgas Statifier					
Lint Baling	Feeder Tramper	Murray Murray/ Atlas	Kicker Paddle 48" long stroke vertical				" "
	Press Pumps (2)	Murray	Triplex 1.3/4" x 4"	Installed 1954			"
	Bale Press - oil hydraulic Manual rotating double box up- packing	Murray	PCX 1952 model 3 Ram	1954			Bale size 55" x 20" x 31" 7 straps 480 lbs. standard density
Bale Conveying	Manual						Condition/operation good
Lugatta Recovery Processing	Manual As s/c through gins						Termed "SCARTO"

TABLE 12.1

Facility	Description	Godiva	Electric start	FWWP 896	Condition good
Fire Fighting	Petrol engine pump from small ground reservoir	Dennis	Trailer/tender		Abandoned - but looks intact
Water Supply	16 lengths canvas/rubber hose - assortment of nozzles 10 x NU Swift extinguishers Shallow well engine driven pump	Numex 6/1 Nelt			Driven by flat belt on pump located within the well. Inaccessible
Fuel Storage	210 litre drums bulk	Braithwaite	5 x 2 x 2		12 x 400 = 4800 galls. (21000 litres)
Office	Surface Water Drainage				
Lower Level Sewage Disposal					
2nd Floor Waste/Access					
Wiring Room					
Fighting					
Gas/Water and Waste Bin/Alcove					
drinking					

Comments: Storage is inadequate. No problems reported. In good condition. In good condition.

TABLE 22.1

GINNERY INVENTORY: BUILDINGS

Building	Description	Approximate dimensions L x W x H (m)	Comments
<b>Main Buildings</b> Ginning factory	Structure : steel portals Walls : aluminium profile sheeting Roof : aluminium profile sheeting Floor : concrete	54 x 15 x 6.5	A cut off for water has been constructed to stop seepage to seed and trash conveyor motor housings in floor.
Mixing room	Construction same as ginnery factory	24 x 15 x 6.5	In good condition, no remedial works required.
Seed room	Construction same as ginnery factory	19 x 12.5 x 6.5	In good condition, no remedial works required.
Power room	Construction same as ginnery factory	12 x 9.5 x 6.5	In good condition, no remedial works required.
Office	Structure : load bearing brickwork Walls : brickwork Roof : GCI and asbestos cement sheeting Floor : cement tiles	34 x 6 x 4	In good condition, no remedial works required.
Store	Structure : steel framed structures and trusses Walls : GCI sheeting Roof : GCI sheeting Floor : GCI sheeting	30 x 12 x 4	In good condition, no remedial works required.
Workshop	Construction same as store	10 x 8 x 4	In good condition, no remedial works required.
<b>Other Buildings</b> Latrine blocks Guard rooms	Bricks and GCI sheeting	various	In good condition

TABLE 22.2

GINNERY INVENTORY:INFRASTRUCTURE

LOCATION:DAMAZIN

Facility	Description	Comments
<b>Water Supply</b>		
(a) Firefighting	Municipal supply to two ground tanks (3 000 gallons each). Water is pumped from the ground tanks with hoses for yard firefighting. Hose reels and water points from the municipal supply and booster pump from ground tanks are provided in the factory.	Storage is inadequate.
(b) Domestic and other uses	Municipal supply distributed by galvanised steel pipes.	No problems reported.
<b>Surface Water Drainage</b>	No special provisions.	Sheet flooding occurs in the yard from the east and west. Protective measures to be considered.
<b>Sewage Disposal</b>	Aqua privies.	
<b>Roads/Access</b>	Gravel road from town main roads to factory. No surfaced roads within factory site. Site is adjacent to Sudan Railways station.	
<b>Fencing</b>	Barbed wire and steel angle posts.	In good condition.
<b>Platforms and Hardstandings</b>	2 700 m <sup>2</sup> concrete platform adjacent to pressroom. 650 m <sup>2</sup> concrete hardstanding in front of mixing and seed rooms.	In good condition.
<b>Houses</b>	Senior type Middle type Junior type	In good condition.
	Constructed in brick with GCI sheeting roofs and concrete tile tile floors. Aqua privies.	



Category	Manufacturer	Equipment Description	Year	Model No.	Power (KW)	Operational Status
S/C Cleaning	Murray Piritininga	2 No. 72" x 7 cylinder inclined cleaners	1976	10553501	15 KW	Operation/condition good
		35/40 Trash/Pull Fan(1)	"	"	15 KW	"
		35/40 Trash/Pull Fan(2)	"	10539801	30 KW	Some small leaks in pipework
			"	10496101	30 KW	"
Gin Feeders	Murray Piritininga Mitchell	3 No. Cotton King Extractors Model CK 2983/1	"	10505001		Operation/condition good
			"	10445701		Manual and auto feed controls operational.
			"	"		
Gin Stands	Murray Piritininga	3 No. 142 x 18" OD brush gins	"	10540001	56 KW	Operation/condition good
		(2)	"	10426101	56 KW	"
		(3)	"	10540001	56 KW	"
Cotton Seed Conveying	"	12" OD Screw	"	N/A	7.5 KW	Operation/condition good
	"	Vacuum Dropper	"	N/A	19 KW	"
	Sutorbilt	8 lb/sq.in.-seed blower	"	N/A		"
Trash Removal	Murray Piritininga	48" OD Cyclone and Vacuum Dropper	1976	N/A		Intact - satisfactory
		24" long conveyor	"	N/A	7.5 KW	Intact
		6 No. double bagging spouts.	"	N/A		Intact
Trash Conveying from Gin Stands	"	12" OD Screw	"	N/A		
		Vacuum Dropper	"			
		Trash Fan 35/40	"	10539801	30 KW	Also acts as o/flow sep. pull fan

LOCATION: DUNNIN

1987E 35'2 (cont)

СИМЕЛ ИМЕНОВА: ИВЧИМЕНЕЛ

TABLE 22.3 (cont.)

GINNERY INVENTORY : MACHINERY

LOCATION : DAMAZIN

System	Method	Make	Type	Year	Serial Nr	Power	Comment	
Cotton Lint Lint Conveying	Saw Brush Draught	Murray Piritininga	40" wide x 68" OD 29" OD Condenser V.A. Fan	1976 " "	N/A  N/A N/A	2.2 KW 30 KW	Condition good Good Good	
	Battery Condenser	"	"	"	"	"	"	
	Tramper Feeder - mechanical	"	Pneumatic pusher Compressor	"	"	7.5 KW	Condition/operation good " "	
Lint Baling	Mechanical Tramper	"	Atlas gear & Chain 20" x 40" PCX, 2 ram up-packing, standard density, revolving boxes	"	N/A N/A	15 KW	" "	
	Oil Hydraulic bale press	"	"	"	"	"	"	
Lint Cleaning	Press Pump	Abex Denison	Vane & Piston Pumps(1) (2)	"	N/A	37 KW 37 KW	" "	
	Box Turning - mechanical Door locks	Murray Piritininga	Powered chain drive Powered hydraulic	1976 "	N/A N/A	6 KW 6 KW	Good Good	
	Saw Type Cleaners		"	Model 100 - 3 No. (1) (2) (3)	"	10505101	19 KW	Intact
					"	10540101	19 KW	"
					"	"	19 KW	"
					"	10553801	15 KW	"
Overflow Separator		"	29" OD V.A.Fans (2) (3)	"	"	15 KW	"	
				"	"	15 KW	"	
Trash Fan 35/40		"	Trash Fan 35/40	"	10555001	30 KW	"	

Category	Item	Murray	Inline Filters	1976	N/A	Power	Notes
Trash Collection	Condenser			1976	N/A	0.75 KW	Screens removed - now acting as expansion boxes.
	Lint Cleaners	Piritinga	3 No. Inline Filters (1) (2) (3)	"	N/A	0.75 KW	"
				"	N/A	0.75 KW	"
Water Supply	Lint Fly Suction Fan	"	35/40 Fan	"	N/A	30 KW	Operational
	Cyclones		10 No. 48" OD	"	N/A	-	Good - located on wrong side of building - i.e. prevailing wind blows some fine dust back into gin building.
Water Supply	By tanker until recently. New town supply now operational.						
	2 No. Storage Tanks - ground level						Temporary arrangement. High level tank required.
Fire Fighting	Water pump and hoses	Coventry Climax/ Godiva.	4 cyl-petrol engine Centrifugal pump		GPC 5721187		Condition/operation good
	Maintenance						Minimal. Main MFC workshops carry out any major repairs
Lugata Recovery Processing	Manual						Need for Lugatta cleaning plant.
	Nil machinery						

TABLE 22.4

GINNERY INVENTORY: POWER SUPPLY

LOCATION: DAMAZIN

Power supply	HV switchgear	LV switchgear	Distribution transformers	Power factor correction
<p>NEC-11kV</p> <p>Driescher 1977</p> <p>11 kV, 630 A, 250 MVA</p> <p>fault current rating</p>	<p>Klockner Moeller</p> <p>415 V, 2000 A</p> <p>type ID200-ZST</p> <p>1977</p> <p>Klockner Moeller</p> <p>415 V motor control centre</p> <p>1977 approx.</p>	<p>1 x 1000 kVA, 11 000/433 V, 1977 approx.</p> <p>6 x 40 kVAR automatic</p>	<p>Power factor correction</p>	

С/Л	Год	Адрес	Содержание	Размеры	Сумма	Примечание
С/Л 1	1957	Адрес	1. Ремонт...	28.0 x 0.2 x 2.2	55.2	Лабель...
С/Л 2	1960	Адрес	2. Ремонт...	90.6 x 0.6 x 3.3	21.5	20% от ССЗ...
С/Л 3	1961	Адрес	3. Ремонт...	28.0 x 0.2 x 2.2	53.1	55% от ССЗ...
С/Л 4	1955	Адрес	4. Ремонт...	90.6 x 0.6 x 6	25.0	Валы...
С/Л 5	1958	Адрес	5. Ремонт...	28.0 x 0.2 x 0.8	53.8	Автомат...
С/Л 6	1959	Адрес	6. Ремонт...	90.6 x 0.6 x 6	25.6	Валы...
С/Л 7	1958	Адрес	7. Ремонт...	28.0 x 0.2 x 0.8	55.8	Автомат...
С/Л 8	1960	Адрес	8. Ремонт...	90.6 x 0.6 x 6	25.6	Валы...
С/Л 9	1958	Адрес	9. Ремонт...	28.0 x 0.2 x 0.8	55.8	Автомат...
С/Л 10	1958	Адрес	10. Ремонт...	90.6 x 0.6 x 6	25.6	Валы...
С/Л 11	1958	Адрес	11. Ремонт...	28.0 x 0.2 x 0.8	55.8	Автомат...
С/Л 12	1958	Адрес	12. Ремонт...	90.6 x 0.6 x 6	25.6	Валы...
С/Л 13	1958	Адрес	13. Ремонт...	28.0 x 0.2 x 0.8	55.8	Автомат...
С/Л 14	1958	Адрес	14. Ремонт...	90.6 x 0.6 x 6	25.6	Валы...
С/Л 15	1958	Адрес	15. Ремонт...	28.0 x 0.2 x 0.8	55.8	Автомат...
С/Л 16	1958	Адрес	16. Ремонт...	90.6 x 0.6 x 6	25.6	Валы...
С/Л 17	1958	Адрес	17. Ремонт...	28.0 x 0.2 x 0.8	55.8	Автомат...
С/Л 18	1958	Адрес	18. Ремонт...	90.6 x 0.6 x 6	25.6	Валы...
С/Л 19	1958	Адрес	19. Ремонт...	28.0 x 0.2 x 0.8	55.8	Автомат...
С/Л 20	1958	Адрес	20. Ремонт...	90.6 x 0.6 x 6	25.6	Валы...
С/Л 21	1958	Адрес	21. Ремонт...	28.0 x 0.2 x 0.8	55.8	Автомат...
С/Л 22	1958	Адрес	22. Ремонт...	90.6 x 0.6 x 6	25.6	Валы...
С/Л 23	1958	Адрес	23. Ремонт...	28.0 x 0.2 x 0.8	55.8	Автомат...
С/Л 24	1958	Адрес	24. Ремонт...	90.6 x 0.6 x 6	25.6	Валы...
С/Л 25	1958	Адрес	25. Ремонт...	28.0 x 0.2 x 0.8	55.8	Автомат...
С/Л 26	1958	Адрес	26. Ремонт...	90.6 x 0.6 x 6	25.6	Валы...
С/Л 27	1958	Адрес	27. Ремонт...	28.0 x 0.2 x 0.8	55.8	Автомат...
С/Л 28	1958	Адрес	28. Ремонт...	90.6 x 0.6 x 6	25.6	Валы...
С/Л 29	1958	Адрес	29. Ремонт...	28.0 x 0.2 x 0.8	55.8	Автомат...
С/Л 30	1958	Адрес	30. Ремонт...	90.6 x 0.6 x 6	25.6	Валы...
С/Л 31	1958	Адрес	31. Ремонт...	28.0 x 0.2 x 0.8	55.8	Автомат...
С/Л 32	1958	Адрес	32. Ремонт...	90.6 x 0.6 x 6	25.6	Валы...
С/Л 33	1958	Адрес	33. Ремонт...	28.0 x 0.2 x 0.8	55.8	Автомат...
С/Л 34	1958	Адрес	34. Ремонт...	90.6 x 0.6 x 6	25.6	Валы...
С/Л 35	1958	Адрес	35. Ремонт...	28.0 x 0.2 x 0.8	55.8	Автомат...
С/Л 36	1958	Адрес	36. Ремонт...	90.6 x 0.6 x 6	25.6	Валы...
С/Л 37	1958	Адрес	37. Ремонт...	28.0 x 0.2 x 0.8	55.8	Автомат...
С/Л 38	1958	Адрес	38. Ремонт...	90.6 x 0.6 x 6	25.6	Валы...
С/Л 39	1958	Адрес	39. Ремонт...	28.0 x 0.2 x 0.8	55.8	Автомат...
С/Л 40	1958	Адрес	40. Ремонт...	90.6 x 0.6 x 6	25.6	Валы...
С/Л 41	1958	Адрес	41. Ремонт...	28.0 x 0.2 x 0.8	55.8	Автомат...
С/Л 42	1958	Адрес	42. Ремонт...	90.6 x 0.6 x 6	25.6	Валы...
С/Л 43	1958	Адрес	43. Ремонт...	28.0 x 0.2 x 0.8	55.8	Автомат...
С/Л 44	1958	Адрес	44. Ремонт...	90.6 x 0.6 x 6	25.6	Валы...
С/Л 45	1958	Адрес	45. Ремонт...	28.0 x 0.2 x 0.8	55.8	Автомат...
С/Л 46	1958	Адрес	46. Ремонт...	90.6 x 0.6 x 6	25.6	Валы...
С/Л 47	1958	Адрес	47. Ремонт...	28.0 x 0.2 x 0.8	55.8	Автомат...
С/Л 48	1958	Адрес	48. Ремонт...	90.6 x 0.6 x 6	25.6	Валы...
С/Л 49	1958	Адрес	49. Ремонт...	28.0 x 0.2 x 0.8	55.8	Автомат...
С/Л 50	1958	Адрес	50. Ремонт...	90.6 x 0.6 x 6	25.6	Валы...

ГОЛОСОВАЯ СЕРВИСНАЯ СЛУЖБА

ТАБЛИЦА № 1

УЧЕТ РАБОТЫ ПО ЗАКАЗАМ

TABLE 23.1

## PORT SUDAN STORES INVENTORY

## LOCATION: CENTRAL AREA

Store Nr	Year of construction	Description	Dimensions L x W x H (m)	Capacity ('000 bales)	Comments
27	1922	Structure : 3 span steel framed stanchions and trusses Walls : concrete wall to 2 m Roof : GCI sheets Floor : concrete Access : rail access both sides, one end door, no platforms	98.6 x 43.6 x 6	22.8	Valley gutters and 10% of GCI sheeting need replacement
26	1922	Structure : 3 span steel framed stanchions and trusses Walls : concrete wall to 2 m Roof : GCI sheets Floor : concrete Access : rail access both sides, one end door, no platforms	98.6 x 43.6 x 6	22.8	Valley gutters and 10% of GCI sheeting need replacement
23	1928	Structure : 2 span steel framed stanchions and trusses Walls : concrete wall to 3 m Roof : GCI sheets Floor : concrete Access : rail access both sides with platform and two end doors	98.6 x 43.6 x 7	22.8	Valley gutters and 25% of GCI sheeting need replacement
30	1928	Structure : 3 span steel framed stanchions and trusses Walls : concrete wall to 2 m Roof : GCI sheets Floor : concrete Access : rail access both sides, no platform	98.6 x 43.6 x 8	22.8	Valley gutter needs replacement
29	1928	Structure : 3 span steel framed stanchions and trusses Walls : concrete wall to 2 m Roof : GCI sheets Floor : concrete Access : rail access both sides, no platform	98.6 x 43.6 x 8	22.8	Valley gutter needs replacement
B/7	1967	Structure : 1 span steel framed stanchions and trusses Walls : concrete wall to 2 m Roof : GCI sheets Floor : concrete Access : rail access one side with platform	98.6 x 43.6 x 5.5	23.1	25% of GCI sheeting needs replacement
E2/9	1961	Structure : 1 span steel framed stanchions and trusses Walls : concrete wall to 2 m Roof : GCI sheets Floor : concrete Access : rail access one side with platform	98.6 x 43.6 x 5.5	22.5	25% of GCI sheeting needs replacement

F1/9	1960	Structure : 1 span steel framed stanchions and trusses Walls : concrete wall to 2 m Roof : GCI sheets Floor : concrete Access : rail access one side with platform	98.6 x 43.6 x 5.5	22.5	25% of GCI sheeting needs replacement
E/9	1955	Structure : 2 span steel framed stanchions and trusses Walls : concrete wall to 2 m Roof : GCI sheets Floor : concrete Access : rail access one side with platform	98.6 x 43.6 x 6	23.0	Valley gutters and 50% of GCI need replacement
E/10	1955	Structure : 2 span steel framed stanchions and trusses Walls : concrete wall to 2 m Roof : GCI sheets Floor : concrete Access : rail access one side with platform	98.6 x 43.6 x 6	23.0	Valley gutters and 50% of GCI need replacement
F2/9	1958	Structure : 2 span steel framed stanchions and trusses Walls : concrete wall to 2 m with central blockwork fire wall Roof : GCI sheets Floor : concrete Access : rail access one side with platform	98.6 x 43.6 x 6	22.5	Valley gutters and 50% of GCI need replacement
G1/10	1958	Structure : 2 span steel framed stanchions and trusses Walls : concrete wall to 2 m with central blockwork fire wall Roof : GCI sheets Floor : concrete Access : rail access one side with platform	98.6 x 43.6 x 6	22.5	Valley gutter and 15% of GCI sheeting need replacement
F2/10	1958	Structure : 2 span steel framed stanchions and trusses Walls : concrete wall to 2 m with central blockwork fire wall Roof : GCI sheets Floor : concrete Access : rail access one side with platform	98.6 x 43.6 x 6	22.5	Valley gutters and 75% of GCI sheeting need replacement
F1/10	1958	Structure : 2 span steel framed stanchions and trusses Walls : concrete wall to 2 m with central blockwork fire wall Roof : GCI sheets Floor : concrete Access : rail access one side with platform	98.6 x 43.6 x 6	22.5	Valley gutters and 15% of GCI sheeting need replacement

TABLE 23.1 (cont.)

Store Nr	Year of construction	Description	Dimensions L x W x H (m)	Capacity (000 bales)	Comments
F2/11	1958	Structure : 2 span steel framed stanchions and trusses Walls : concrete wall to 2 m with central blockwork Roof : GCI sheets Floor : concrete Access : rail access one side with platform	98.6 x 43.6 x 6	22.5	Valley gutters and 100% of GCI sheeting need replacement
F1/11	1958	Structure : 2 span steel framed stanchions and trusses Walls : concrete wall to 2 m with central blockwork Roof : GCI sheets Floor : concrete Access : rail access one side with platform	98.6 x 43.6 x 6	22.5	Valley gutters and 25% of GCI sheeting need replacement
F2/12	1958	Structure : 2 span steel framed stanchions and trusses Walls : concrete wall to 2 m with central blockwork Roof : GCI sheets Floor : concrete Access : rail access one side with platform	98.6 x 43.6 x 6	22.5	Valley gutters and 50% of GCI sheeting need replacement
F1/12	1958	Structure : 2 span steel framed stanchions and trusses Walls : concrete wall to 2 m with central blockwork Roof : GCI sheets Floor : concrete Access : rail access one side with platform	98.6 x 43.6 x 6	22.5	Valley gutters and 75% of GCI sheeting need replacement
F2/13	1955	Structure : 2 span steel framed stanchions and trusses Walls : concrete wall to 2 m Roof : GCI sheets Floor : concrete Access : rail access one side with platform	98.6 x 43.6 x 6	23.0	Valley gutters and 15% of GCI sheeting need replacement
F1/13	1955	Structure : 2 span steel framed stanchions and trusses Walls : concrete wall to 2 m Roof : GCI sheets Floor : concrete Access : rail access one side with platform	98.6 x 43.6 x 6	23.0	Valley gutters and 50% of GCI sheeting need replacement

Item	Year	Location	Dimensions	Notes
Roof	1966	...	...	...
Structure	1966	...	...	...
Walls	1966	...	...	...
Floor	1966	...	...	...
Access	1966	...	...	...
Roof	1966	...	...	...
Structure	1966	...	...	...
Walls	1966	...	...	...
Floor	1966	...	...	...
Access	1966	...	...	...
Roof	1966	...	...	...
Structure	1966	...	...	...
Walls	1966	...	...	...
Floor	1966	...	...	...
Access	1966	...	...	...
Roof	1966	...	...	...
Structure	1966	...	...	...
Walls	1966	...	...	...
Floor	1966	...	...	...
Access	1966	...	...	...

1966

1966

1966

1966

1966

1966

1966

1966

1966

1966

1966

1966

1966

1966

1966

1966

1966

1966

1966

1966

1966

1966

1966

1966

1966

1966

1966

1966

1966

1966

1966

1966

1966

1966

1966

1966

1966

1966

1966

1966

1966

1966

1966

1966

1966

1966

1966

1966

1966

1966

1966

1966

1966

1966

1966

1966

1966

1966

1966

1966

1966

1966

1966

1966

1966

1966

1966

1966

1966

1966

1966

1966

1966

1966

1966

1966

1966

1966

1966

1966

1966

1966

1966

1966

1966

1966

1966

1966

1966

1966

1966

1966

1966

1966

1966

1966

1966

1966

1966

1966

1966

1966

1966

1966

1966

1966

1966

1966

1966

1966

1966

1966

1966

1966

1966

1966

1966

1966

1966

1966

1966

1966

1966

1966

1966

1966

1966

1966

1966

1966

1966

1966

1966

1966

1966

1966

1966

1966

1966

1966

1966

1966

1966

1966

1966

1966

1966

1966

1966

1966

1966

1966

1966

1966

1966

1966

1966

1966

1966

1966

1966

1966

1966

1966

1966

1966

1966

1966

1966

1966

1966

1966

1966

1966

1966

1966

1966

1966

1966

1966

1966

1966

1966

1966

1966

1966

1966

1966

1966

1966

1966

1966

1966

1966

1966

1966

1966

1966

1966

1966

1966

1966

1966

1966

1966

## PORT SUDAN STORES INVENTORY

TABLE 23.2

LOCATION: NORTHERN AREA

Store Nr	Year of construction	Description	Dimensions L x W x H (m)	Capacity ('000 bales)	Comments
O/1	1962	Structure : 1 span steel framed stanchions and trusses Walls : concrete wall to 2 m Roof : GCI sheets Floor : concrete Access : rail access one side, 3.5 m platform one side	98.6 x 39 x 7	20.0	Door rails and platform need repair
P/1	1962	Structure : 2 span steel framed stanchions and trusses Walls : concrete wall to 2 m Roof : GCI sheets Floor : concrete Access : rail access one side, 3.5 m platform one side	98.6 x 39 x 7	20.0	5% of floor needs repair. Door rails need replacement. Valley gutter and 10% of GCI sheeting needs replacement
P/2	1962	Structure : 1 span steel framed stanchions and trusses Walls : concrete wall to 2 m, central concrete fire wall Roof : GCI sheets Floor : concrete Access : rail access one side, 3.5 m platform one side	98.6 x 39 x 7	20.0	Door rails and platform need repair
Q/1	1962	Structure : 2 span steel framed stanchions and trusses Walls : concrete wall to 2 m Roof : GCI sheets Floor : concrete Access : rail access one side, 3.5 m platform one side	98.6 x 39 x 7	20.0	Door rails to be renewed, platform needs maintenance
Q/2	1962	Structure : 1 span steel framed stanchions and trusses Walls : concrete wall to 2 m, central fire wall Roof : GCI sheets Floor : concrete Access : rail access one side, 3.5 m platform one side	98.6 x 39 x 7	20.0	Door rails and platform need replacement and maintenance
R/1	1962	Structure : 1 span steel framed stanchions and trusses Walls : concrete wall to 2 m Roof : GCI sheets Floor : concrete Access : rail access one side, 3.5 m platform one side	98.6 x 39 x 7	20.0	3 doors and rails need repair

R/2	1962	Structure : 1 span steel framed stanchions and trusses Walls : concrete wall to 2 m, central fire wall Roof : GCI sheets Floor : concrete Access : rail access one side, 3.5 m platform one side	98.6 x 39 x 7	20.0	Door rails need repair
S/1	1962	Structure : 2 span steel framed stanchions and trusses Walls : concrete wall to 2 m Roof : GCI sheets Floor : concrete Access : rail access one side, 3.5 m platform one side	98.6 x 39 x 7	20.0	Door rails need repair
S/2	1962	Structure : 1 span steel framed stanchions and trusses Walls : concrete wall to 2 m, central fire wall Roof : GCI sheets Floor : concrete Access : rail access one side, 3.5 m platform one side	98.6 x 39 x 7	20.0	Valley gutter and 10% GCI and door rails need replacement
C/2	1966	Structure : 1 span steel portal frames Walls : cement block walls to eaves Roof : coated aluminium sheets Floor : concrete Access : rail access one side, 3.5 m platform one side	98.6 x 39 x 7	20.0	Doors need to be repaired and fixed on independent supports - platform to be repaired
C/3	1966	Structure : 1 span steel portal frames Walls : cement block walls to eaves Roof : coated aluminium sheets Floor : concrete Access : rail access one side, 3.5 m platform one side	98.6 x 39 x 7	20.0	Doors need to be repaired and fixed on independent supports - platform to be repaired
C/4	1966	Structure : 1 span steel portal frames Walls : cement block walls to eaves Roof : coated aluminium sheets Floor : concrete Access : rail access one side, 3.5 m platform one side	98.6 x 39 x 7	20.0	Doors need to be repaired and fixed on independent supports - platform to be repaired
C/5	1966	Structure : 1 span steel portal frames Walls : cement block walls to eaves Roof : coated aluminium sheets Floor : concrete Access : rail access one side, 3.5 m platform one side	98.6 x 39 x 7	20.0	Doors need to be repaired and fixed on independent supports - platform to be repaired

TABLE 23.3

PORT SUDAN STORES INVENTORY

LOCATION: HADALI AREA

Store Nr	Year of construction	Description	Dimensions L x W x H (m)	Capacity ('000 bales)	Comments
H/29	1970	Structure : 1 span steel portal frames Walls : concrete wall to 3.5 m Roof : GCI sheets Floor : concrete Access : rail access one side, 3.5 m platform one side	104 x 34.5 x 7	17.0	None
H/30	1970	Structure : 1 span steel portal frames Walls : concrete wall to 3.5 m Roof : GCI sheets Floor : concrete Access : rail access one side, 3.5 m platform one side	104 x 34.5 x 7	17.0	None
H/27	1979	Structure : 1 span steel portal frames Walls : cement block wall to 3.5 m Roof : GCI sheets Floor : concrete Access : rail access one side, 3.5 m platform one side	104 x 34.5 x 7	13.0	Platform maintenance required
H/34	1979	Structure : 1 span steel portal frames Walls : cement block wall to 3.5 m Roof : GCI sheets Floor : concrete Access : rail access one side, 3.5 m platform one side	104 x 34.5 x 7	13.0	Platform needs maintenance. Sprinkler system not yet installed
H/37	1979	Structure : 1 span steel portal frames Walls : cement block wall to 3.5 m Roof : GCI sheets Floor : concrete Access : rail access one side, 3.5 m platform one side	105 x 34.5 x 7	13.0	Platform needs maintenance. Sprinkler system not yet installed



TABLE 24.1

## Characteristic Climatic Parameters

GINNERIES : MARANGAN AND HASAHEISA  
METEOROLOGICAL STATION : WAD MEDANI

Element Record length	Relative humidity % 30 years			Air temperature °C 30 years		Rainfall (mm) 30 years	
	0600	1200	1800	Daily maximum	Daily minimum	Total	Nr of days ≥ 10.0
Month				Mean	Mean		
Jan	38	18	30	33.6	14.0	tr	0
Feb	29	13	22	35.1	14.9	tr	0
Mar	22	10	16	38.4	18.2	tr	0
Apr	18	09	15	40.8	21.1	1	0
May	30	15	23	41.4	23.9	15	0.4
Jun	48	23	35	39.7	24.6	29	0.9
Jul	68	39	55	35.8	22.8	116	3.8
Aug	79	51	69	33.3	21.9	133	4.5
Sep	72	42	62	35.3	21.8	48	1.6
Oct	52	27	45	37.8	21.6	19	0.4
Nov	37	19	34	36.5	18.0	1	0
Dec	40	19	33	33.8	14.5	tr	0
Year	44	24	37	36.8	19.8	362	11.6

TABLE 24.2

## Characteristic Climatic Parameters

GINNERY : BAGEIR GINNERY  
METEOROLOGICAL STATION : KHARTOUM

Element Record length	Relative humidity % 30 years			Air temperature °C 30 years		Rainfall (mm) 30 years	
	0600	1200	1800	Daily maximum	Daily minimum	Total	Nr of days ≥ 10.0
Month				Mean	Mean		
Jan	35	21	27	31.7	16.0	tr	0
Feb	28	17	22	33.2	16.7	tr	0
Mar	23	13	18	37.0	19.9	tr	0
Apr	21	13	18	40.1	23.0	tr	0
May	26	15	22	41.9	26.3	5	0
Jun	39	18	25	41.6	27.1	5	0.2
Jul	59	31	41	38.1	25.7	55	1.7
Aug	68	40	52	36.2	24.8	72	2.3
Sep	54	29	40	38.4	25.6	25	0.7
Oct	37	21	29	39.3	25.2	5	0.1
Nov	34	21	28	35.8	21.2	tr	0
Dec	38	22	29	32.3	16.9	tr	0
Year	39	22	29	37.1	22.4	167	5.1

TABLE 24.3

## Characteristic Climatic Parameters

GINNERIES : SENNAR AND HAMADNALLAH  
METEOROLOGICAL STATION : SENNAR

Element Record length	Relative humidity % 14 years			Air temperature °C 28 years		Rainfall (mm) 30 years	
	0600	1200	1800	Daily maximum	Daily minimum	Total	Nr of days ≥ 10.0
				Mean	Mean		
Month							
Jan	39	22		34.4	15.2	tr	0
Feb	32	18		35.8	15.9	tr	0
Mar	26	17		39.0	19.0	1	0
Apr	24	16		40.9	21.6	4	0
May	36	19		40.9	24.1	21	0.6
Jun	52	30		38.6	23.7	50	1.6
Jul	69	43		34.7	22.0	138	4.5
Aug	77	53		32.7	21.3	166	5.3
Sep	71	45		34.8	21.3	61	2.1
Oct	56	34		37.7	21.7	31	0.7
Nov	39	25		37.0	19.5	tr	0
Dec	39	25		33.5	15.9	0	0
Year	47	29		36.7	20.1	472	14.8

TABLE 24.4

## Characteristic Climatic Parameters

GINNERY : DUEIM GINNERY  
METEOROLOGICAL STATION : DUEIM

Element Record length	Relative humidity % 29 years			Air temperature °C 29 years		Rainfall (mm) 30 years	
	0600	1200	1800	Daily maximum	Daily minimum	Total	Nr of days ≥ 10.0
				Mean	Mean		
Month							
Jan	38	25		32.1	16.4	0	0
Feb	34	20		33.3	17.1	tr	0
Mar	29	17		37.3	19.8	tr	0
Apr	26	16		40.0	21.7	4	0.1
May	32	20		41.1	24.2	8	0.2
Jun	49	27		39.6	24.4	24	0.8
Jul	65	38		36.0	23.4	79	2.6
Aug	73	48		34.0	22.7	108	3.4
Sep	67	41		35.9	22.7	47	1.6
Oct	52	32		37.9	23.2	10	0.2
Nov	39	24		35.9	20.7	tr	0
Dec	40	25		32.7	17.2	0	0
Year	45	28		36.3	21.1	280	8.9

TABLE 24.5

## Characteristic Climatic Parameters

GINNERIES : KOSTI AND RABAK  
METEOROLOGICAL STATION : KOSTI

Element Record length	Relative humidity % 30 years			Air temperature °C 30 years		Rainfall (mm) 30 years	
	0600	1200	1800	Daily maximum	Daily minimum	Total	Nr of days ≥ 10.0
				Mean	Mean		
Month							
Jan	39	23	42	32.9	16.7	tr	0
Feb	31	18	35	34.5	17.4	tr	0
Mar	26	14	30	37.3	20.2	1	0
Apr	24	13	26	40.5	22.5	2	0
May	40	21	32	40.5	24.9	16	0.7
Jun	58	32	44	38.1	24.9	39	1.1
Jul	74	46	61	34.6	23.3	111	3.4
Aug	83	57	74	32.4	22.5	142	4.3
Sep	76	47	68	34.5	22.5	63	2.1
Oct	59	31	52	37.2	22.9	21	0.5
Nov	39	23	44	36.2	21.0	1	0
Dec	39	24	45	33.3	17.6	tr	0
Year	49	29	46	36.0	21.4	396	12.1

TABLE 24.6

## Characteristic Climatic Parameters

GINNERY : FAU GINNERY  
METEOROLOGICAL STATION : GEDAREF

Element Record length	Relative humidity % 11 years			Air temperature °C 30 years		Rainfall (mm) 30 years	
	0600	1200	1800	Daily maximum	Daily minimum	Total	Nr of days ≥ 10.0
				Mean	Mean		
Month							
Jan	51	23	28	34.9	17.3	tr	0
Feb	45	23	24	36.1	18.2	tr	0
Mar	35	19	22	38.7	21.2	1	0
Apr	31	19	22	40.2	23.6	4	0.1
May	38	23	33	40.0	24.6	27	0.8
Jun	56	33	45	37.1	23.0	86	2.8
Jul	71	47	63	32.8	21.5	154	4.8
Aug	77	57	76	31.1	20.9	188	6.6
Sep	71	49	70	33.1	21.2	92	3.5
Oct	57	33	51	36.5	21.7	24	1.0
Nov	43	25	33	36.9	21.0	3	0.1
Dec	48	25	31	35.1	18.2	0	0
Year	52	31	41	36.0	21.0	579	19.7

TABLE 24.7

## Characteristic Climatic Parameters

GINNERIES : NEW HALFA GINNEYRY

METEOROLOGICAL STATION : HALFA EL GEDIDA

Element Record length	Relative humidity % 7 years			Air temperature °C 7 years		Rainfall (mm) 30 years	
	0600	1200	1800	Daily	Daily	Total	Nr of days ≥ 10.0
				maximum	minimum		
Month	0600	1200	1800	Mean	Mean		
Jan	58	25	-	33.3	14.1	0	0
Feb	60	24	-	35.0	15.3	tr	0
Mar	53	17	-	39.6	16.9	tr	0
Apr	52	23	-	41.7	20.3	2	0.1
May	42	20	-	42.9	23.1	11	0.3
Jun	49	23	-	41.3	23.1	25	0.8
Jul	64	34	-	36.8	22.9	118	3.8
Aug	73	40	-	35.2	21.9	133	4.6
Sep	59	34	-	37.6	22.0	60	2.1
Oct	59	29	-	39.3	21.2	9	0.2
Nov	53	24	-	37.4	18.3	tr	0
Dec	62	28	-	34.9	15.0	tr	0
Year	57	27	-	37.9	19.5	358	11.9

TABLE 24.8

## Characteristic Climatic Parameters

GINNERY : ZEIDAB GINNEYRY

METEOROLOGICAL STATION : ATBARA

Element Record length	Relative humidity % 30 years			Air temperature °C 28 years		Rainfall (mm) 30 years	
	0600	1200	1800	Daily	Daily	Total	Nr of days ≥ 10.0
				maximum	minimum		
Month	0600	1200	1800	Mean	Mean		
Jan	44	23	32	30.5	14.7	tr	0
Feb	36	18	24	32.0	15.3	tr	0
Mar	27	13	19	35.9	18.4	tr	0
Apr	22	11	17	39.3	21.9	tr	0
May	22	12	18	42.1	25.8	3	0.1
Jun	25	13	19	43.0	28.0	2	0.1
Jul	43	21	30	40.4	27.2	27	0.7
Aug	51	26	37	39.4	25.8	31	1.0
Sep	37	18	27	41.0	27.1	5	0.1
Oct	33	17	27	39.3	25.6	1	0
Nov	42	23	33	35.0	20.5	tr	0
Dec	46	25	34	31.4	16.0	tr	0
Year	36	18	26	37.4	22.2	69	2.0

TABLE 24.9

## Characteristic Climatic Parameters

GINNERY : PORT SUDAN GINNERY  
 METEOROLOGICAL STATION : PORT SUDAN

Element Record length	Relative humidity % 30 years			Air temperature °C 30 years		Rainfall (mm) 30 years	
				Daily maximum	Daily minimum	Total	Nr of days ≥ 10.0
Month	Mean			Mean	Mean		
Jan	71			26.9	19.7	6	0.2
Feb	72			27.2	19.2	1	0
Mar	70			28.7	19.8	tr	0
Apr	67			31.4	21.5	1	0
May	61			34.9	23.4	1	0.1
Jun	51			38.6	25.7	tr	0
Jul	51			40.5	28.1	5	0.2
Aug	52			40.6	29.1	2	0
Sep	62			37.3	26.7	0	0
Oct	73			33.6	24.9	10	0.3
Nov	74			30.9	23.9	43	1.1
Dec	73			28.2	21.3	15	0.5
Year	65			33.2	23.6	84	2.4

TABLE 24.10

## Characteristic Climatic Parameters

GINNERY : DAMAZIN GINNERY  
 METEOROLOGICAL STATION : DAMAZIN

Element Record length	Relative humidity % 9 years			Air temperature °C 9 years		Rainfall (mm) 30 years	
				Daily maximum	Daily minimum	Total	Nr of days ≥ 10.0
Month	0600	1200	1800	Mean	Mean		
Jan	36	18	27	35.5	16.7	tr	0
Feb	28	16	21	37.1	18.1	tr	0
Mar	26	15	21	39.6	21.7	1	0.1
Apr	30	16	24	40.2	23.6	19	1.3
May	47	27	39	38.6	24.9	40	1.2
Jun	69	41	55	35.1	22.8	119	3.6
Jul	81	57	77	31.7	21.5	181	5.2
Aug	87	63	84	30.8	21.1	203	7.2
Sep	82	55	84	32.5	20.9	129	4.4
Oct	71	43	73	34.9	20.5	41	1.0
Nov	44	23	45	36.6	18.6	3	0.1
Dec	36	19	32	35.9	16.3	tr	0
Year	53	33	49	35.6	20.6	736	24.1

## Marangan Ginnery

## General Layout

TABLE 24.11

## Characteristic Climatic Parameters

GINNERY : NUBA MOUNTAINS GINNERY  
 METEOROLOGICAL STATION : KADUGLI

Element Record length	Relative humidity % 8 years	Air temperature °C 30 years		Rainfall (mm) 30 years	
		Daily maximum	Daily minimum	Total	Nr of days ≥ 10.0
Month	Mean	Mean	Mean		
Jan	23	35.1	17.1	-	-
Feb	20	36.6	18.7	-	-
Mar	22	39.3	21.2	2	0.1
Apr	25	39.9	22.6	14	0.3
May	44	38.1	23.3	81	0.3
Jun	59	34.9	22.3	107	3.4
Jul	70	31.9	21.6	139	4.5
Aug	76	31.0	21.2	172	3.2
Sep	74	32.5	20.6	139	4.8
Oct	61	34.8	19.9	79	2.3
Nov	34	36.7	18.2	2	0.1
Dec	26	35.6	17.2	-	-
Year	45	35.5	20.3	735	19.0

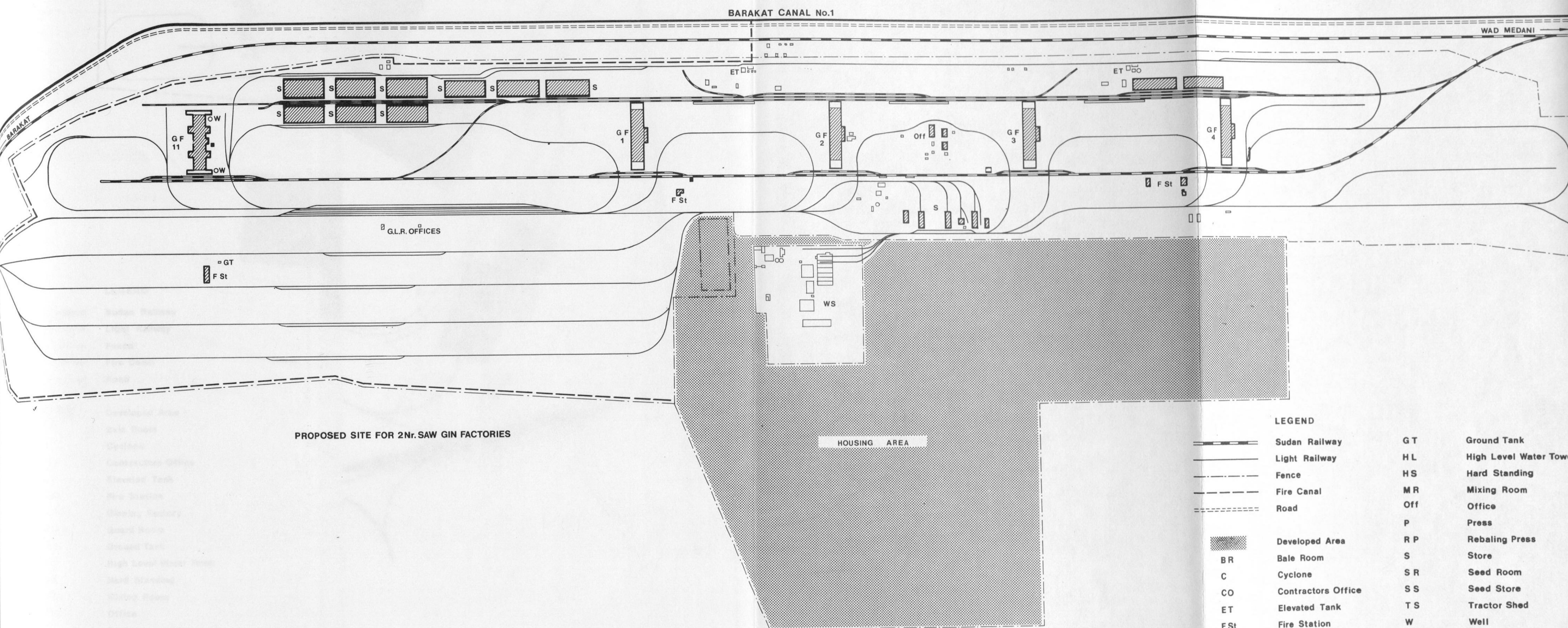
Note : Average annual rainfalls at other sites are :

Dilling (35 years) : 607 mm

Kologi (35 years) : 780 mm

Figure 1

# Marangan Ginnery General Layout



PROPOSED SITE FOR 2nr. SAW GIN FACTORIES

HOUSING AREA

**LEGEND**

	Sudan Railway	GT	Ground Tank
	Light Railway	HL	High Level Water Tower
	Fence	HS	Hard Standing
	Fire Canal	MR	Mixing Room
	Road	Off	Office
	Developed Area	P	Press
BR	Bale Room	RP	Rebaling Press
C	Cyclone	S	Store
CO	Contractors Office	SR	Seed Room
ET	Elevated Tank	SS	Seed Store
FSt	Fire Station	TS	Tractor Shed
GF	Ginning Factory	W	Well
GR	Guard Room	WH	Warehouse
		WS	Workshop

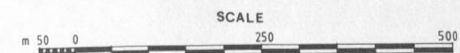


Figure 2

# Hasaheisa Ginnery General Layout

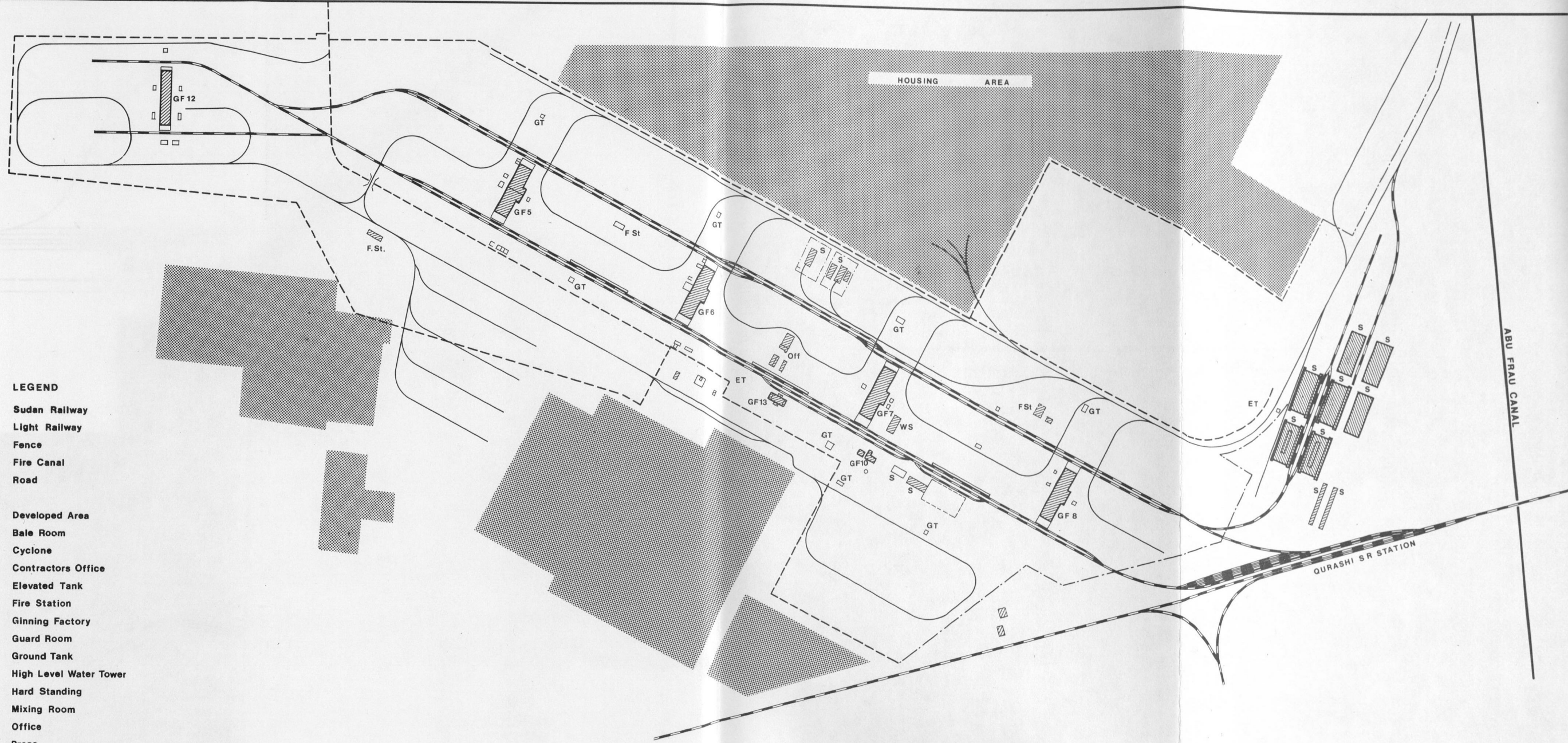


GEZIRA MAIN CANAL



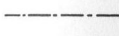
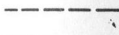
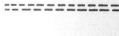

HOUSING AREA

ABU FRAU CANAL

QURASHI SR STATION



### LEGEND

-  Sudan Railway
-  Light Railway
-  Fence
-  Fire Canal
-  Road
-  Developed Area
- BR Bale Room
- C Cyclone
- CO Contractors Office
- ET Elevated Tank
- FSt Fire Station
- GF Ginning Factory
- GR Guard Room
- GT Ground Tank
- HL High Level Water Tower
- HS Hard Standing
- MR Mixing Room
- Off Office
- P Press
- RP Rebaling Press
- S Store
- SR Seed Room
- SS Seed Store
- TS Tractor Shed
- W Well
- WH Warehouse
- WS Workshop

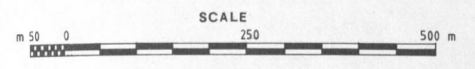
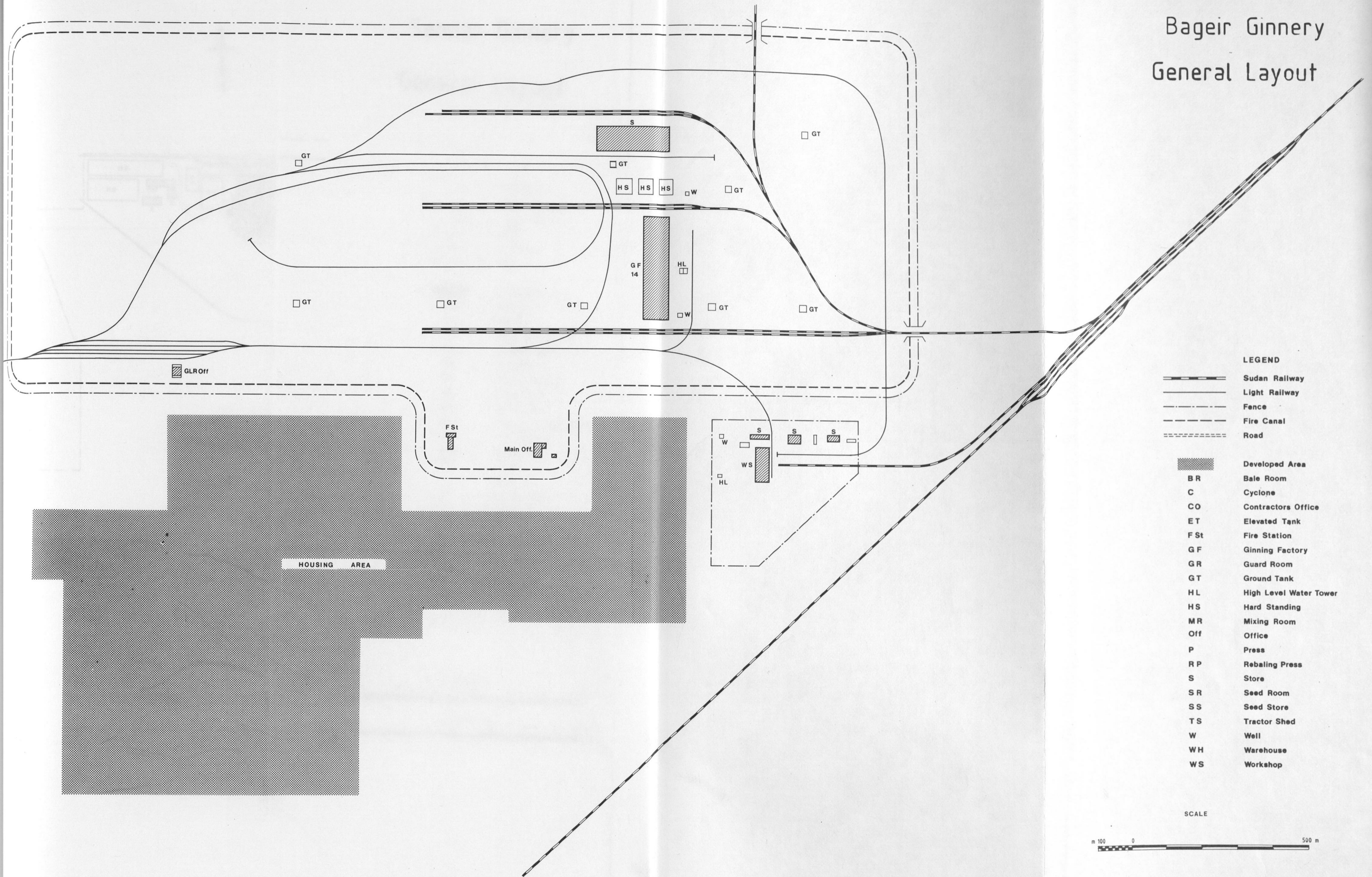


Figure 3

# Bageir Ginnery General Layout



**LEGEND**

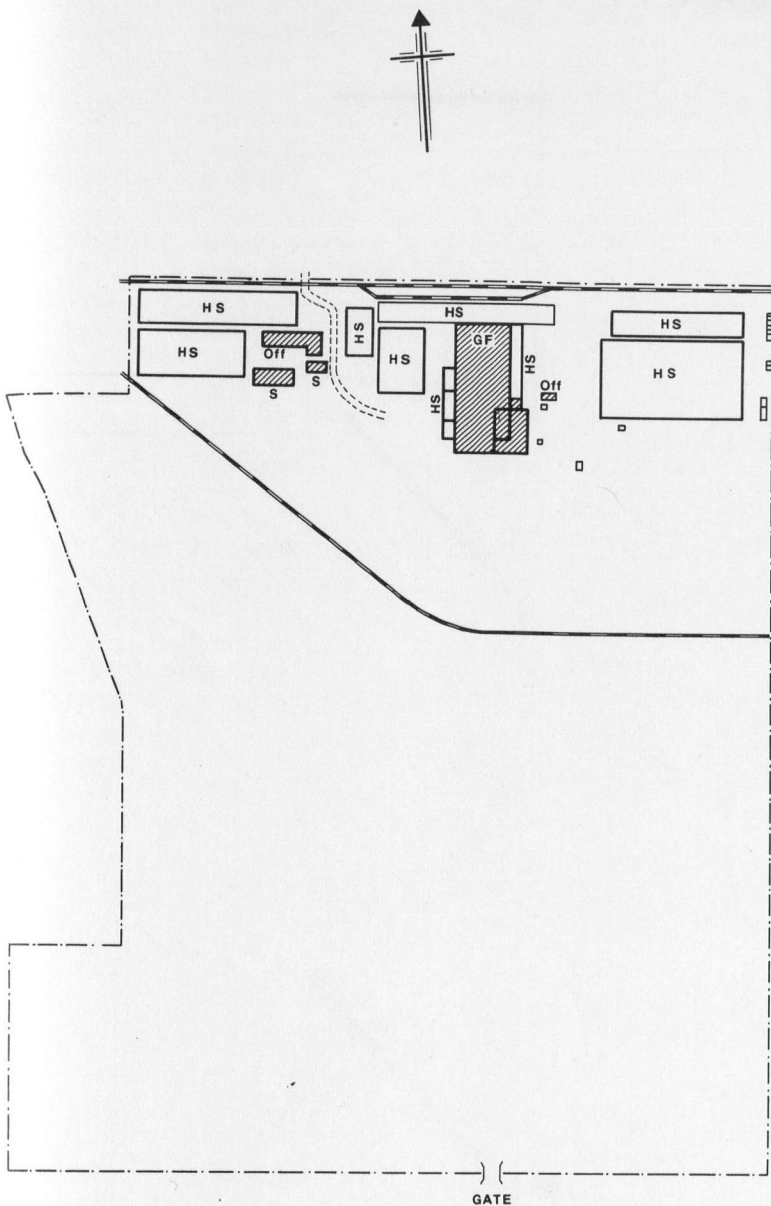
- Sudan Railway
- Light Railway
- Fence
- Fire Canal
- Road
- Developed Area
- BR** Bale Room
- C** Cyclone
- CO** Contractors Office
- ET** Elevated Tank
- FSt** Fire Station
- GF** Ginning Factory
- GR** Guard Room
- GT** Ground Tank
- HL** High Level Water Tower
- HS** Hard Standing
- MR** Mixing Room
- Off** Office
- P** Press
- RP** Rebaling Press
- S** Store
- SR** Seed Room
- SS** Seed Store
- TS** Tractor Shed
- W** Well
- WH** Warehouse
- WS** Workshop

SCALE

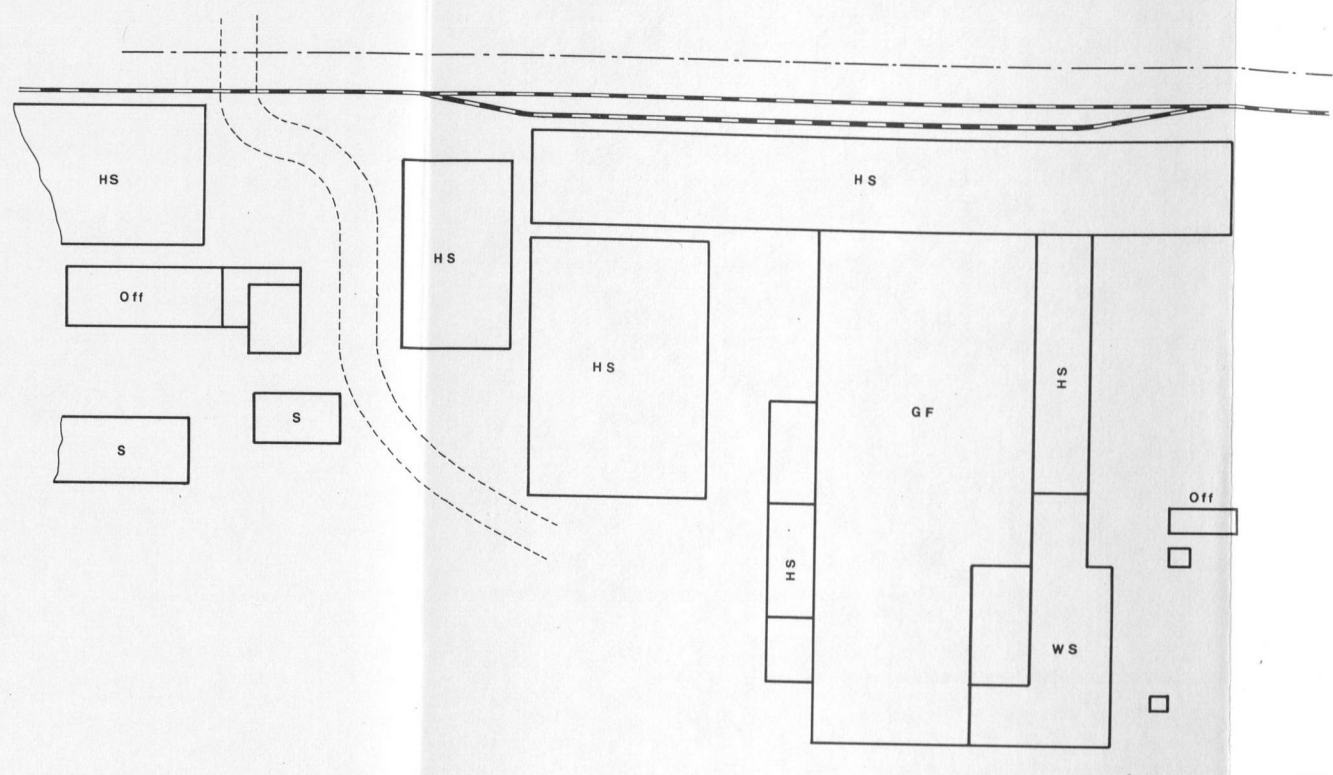


Figure 4

# Sennar Ginnery General Layout



**SITE PLAN**  
SCALE B



**PLAN OF GINNERY**  
SCALE A

**LEGEND**

	Sudan Railway
	Light Railway
	Fence
	Fire Canal
	Road
	Developed Area
BR	Bale Room
C	Cyclone
CO	Contractors Office
ET	Elevated Tank
FSt	Fire Station
GF	Ginning Factory
GR	Guard Room
GT	Ground Tank
HL	High Level Water Tower
HS	Hard Standing
MR	Mixing Room
Off	Office
P	Press
RP	Rebaling Press
S	Store
SR	Seed Room
SS	Seed Store
TS	Tractor Shed
W	Well
WH	Warehouse
WS	Workshop

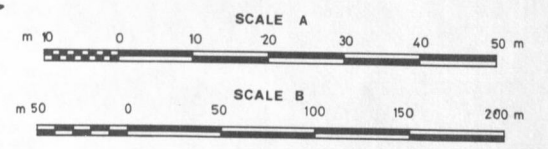
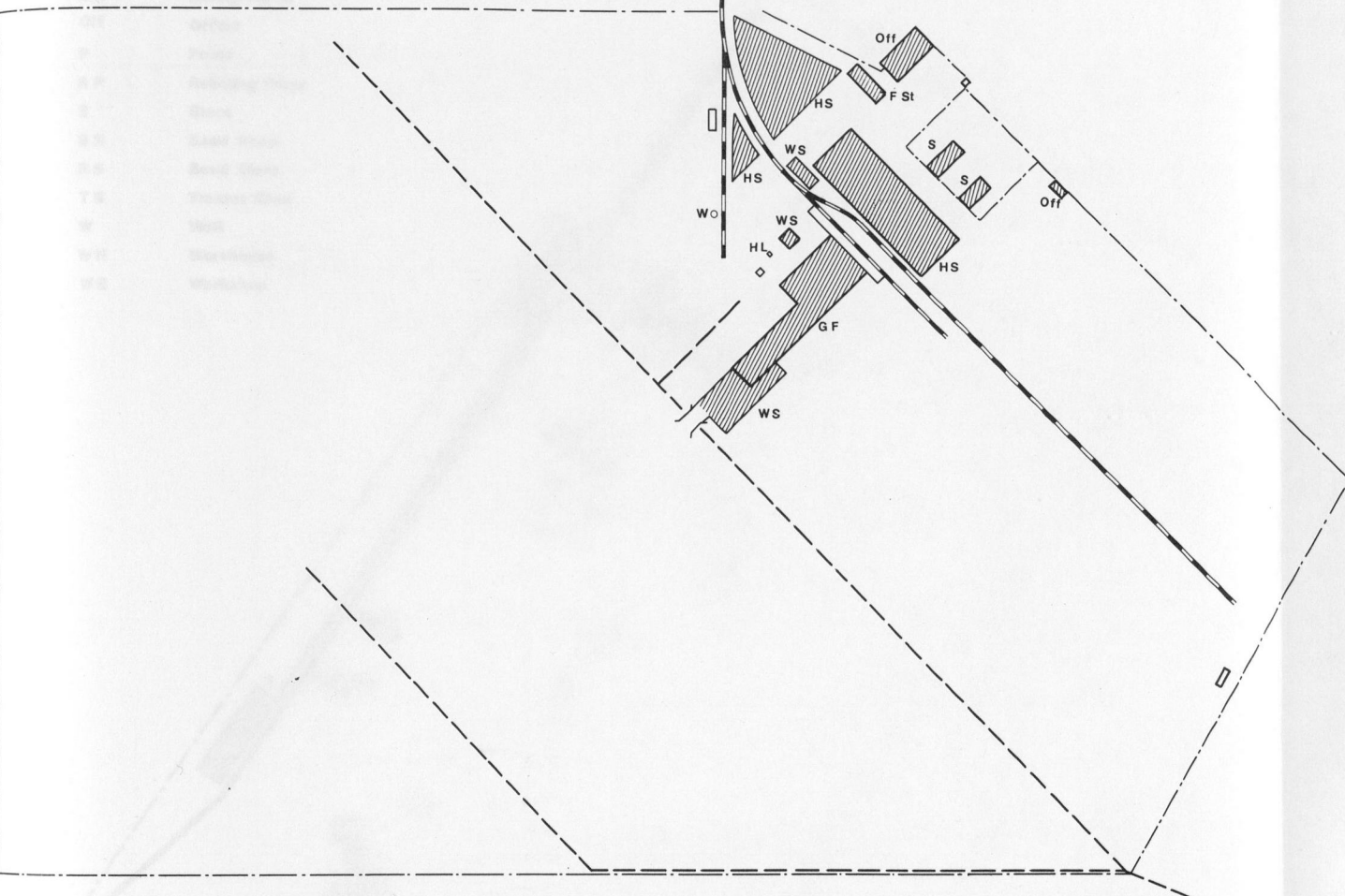
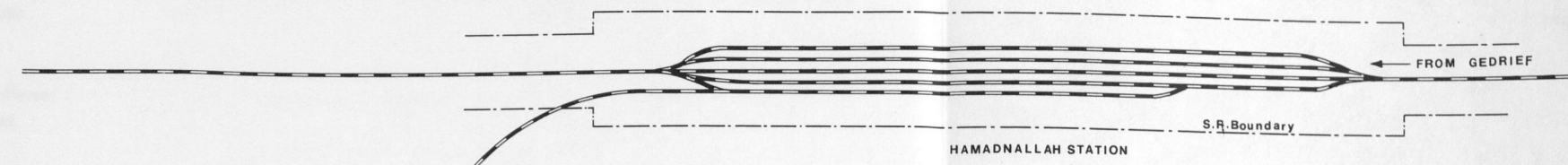


Figure 5  
 Hamadnallah Ginnery  
 General Layout



PLAN OF GINNERY

LEGEND			
	Sudan Railway	GT	Ground Tank
	Light Railway	HL	High Level Water Tower
	Fence	HS	Hard Standing
	Fire Canal	MR	Mixing Room
	Road	Off	Office
	Developed Area	P	Press
BR	Bale Room	RP	Rebaling Press
C	Cyclone	S	Store
CO	Contractors Office	SR	Seed Room
ET	Elevated Tank	SS	Seed Store
F St	Fire Station	TS	Tractor Shed
GF	Ginning Factory	W	Well
GR	Guard Room	WH	Warehouse
		WS	Workshop

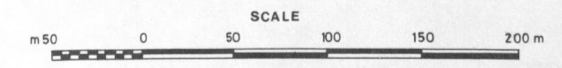

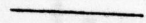
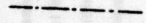
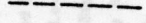
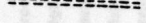

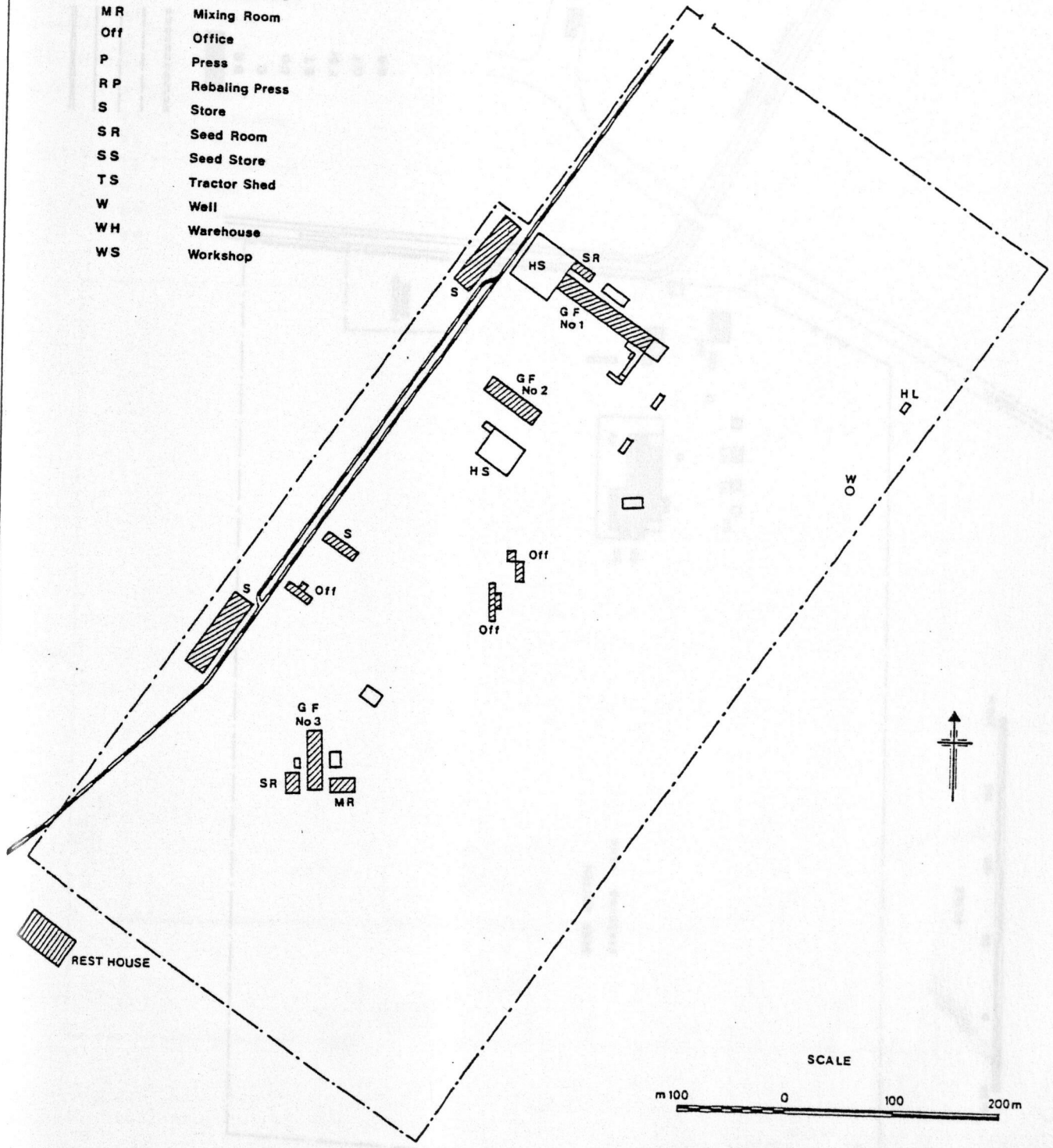


Figure 6

# Kassab Ginnery General Layout

- LEGEND**
-  Sudan Railway
  -  Light Railway
  -  Fence
  -  Fire Canal
  -  Road

-  Developed Area
- BR Bale Room
- C Cyclone
- CO Contractors Office
- ET Elevated Tank
- F St Fire Station
- GF Ginning Factory
- GR Guard Room
- GT Ground Tank
- HL High Level Water Tower
- HS Hard Standing
- SR Seed Room
- MR Mixing Room
- Off Office
- P Press
- RP Rebaling Press
- S Store
- SR Seed Room
- SS Seed Store
- TS Tractor Shed
- W Well
- WH Warehouse
- WS Workshop



SCALE  
m 100 0 100 200m

# Dueim Ginnery General Layout

**LEGEND**

- Sudan Railway
- Light Railway
- - - Fence
- - - Fire Canal
- - - Road

- GT Ground Tank
- HL High Level Water Tower
- HS Hard Standing
- MR Mixing Room
- Off Office
- P Press
- RP Reballing Press
- S Store
- SR Seed Room
- SS Seed Store
- TS Tractor Shed
- W Well
- WH Warehouse
- WS Workshop

- BR Developed Area
- C Bale Room
- CO Cyclone
- ET Contractors Office
- FSI Elevated Tank
- GF Fire Station
- GR Ginning Factory
- Guard Room

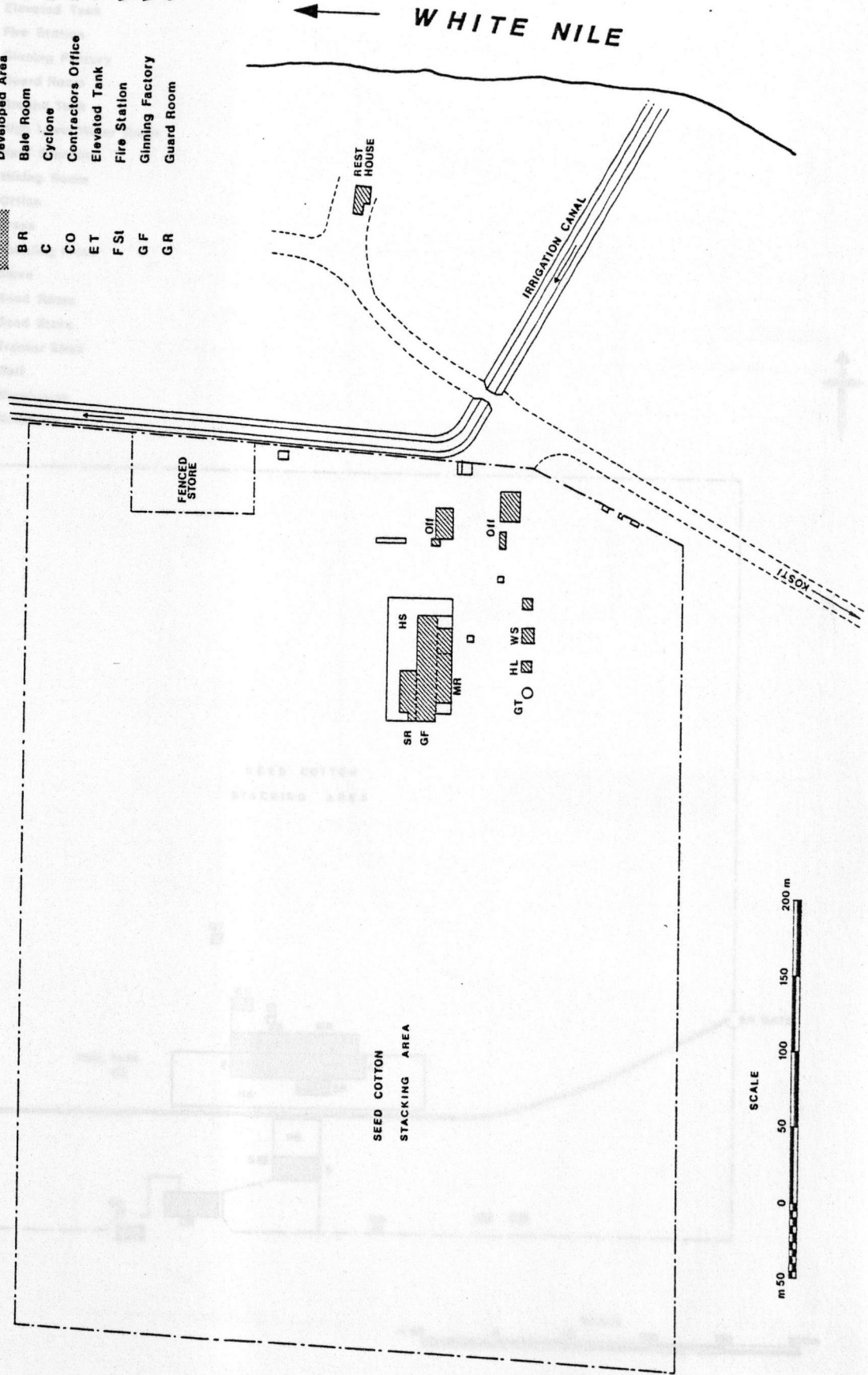

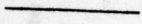
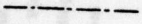
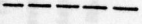
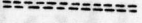



Figure 8

# Kosti Ginnery

## General Layout

### LEGEND

-  Sudan Railway
-  Light Railway
-  Fence
-  Fire Canal
-  Road
  
-  Developed Area
- BR Bale Room
- C Cyclone
- CO Contractors Office
- ET Elevated Tank
- FSt Fire Station
- GF Ginning Factory
- GR Guard Room
- GT Ground Tank
- HL High Level Water Tower
- HS Hard Standing
- MR Mixing Room
- Off Office
- P Press
- RP Rebaling Press
- S Store
- SR Seed Room
- SS Seed Store
- TS Tractor Shed
- W Well
- WH Warehouse
- WS Workshop

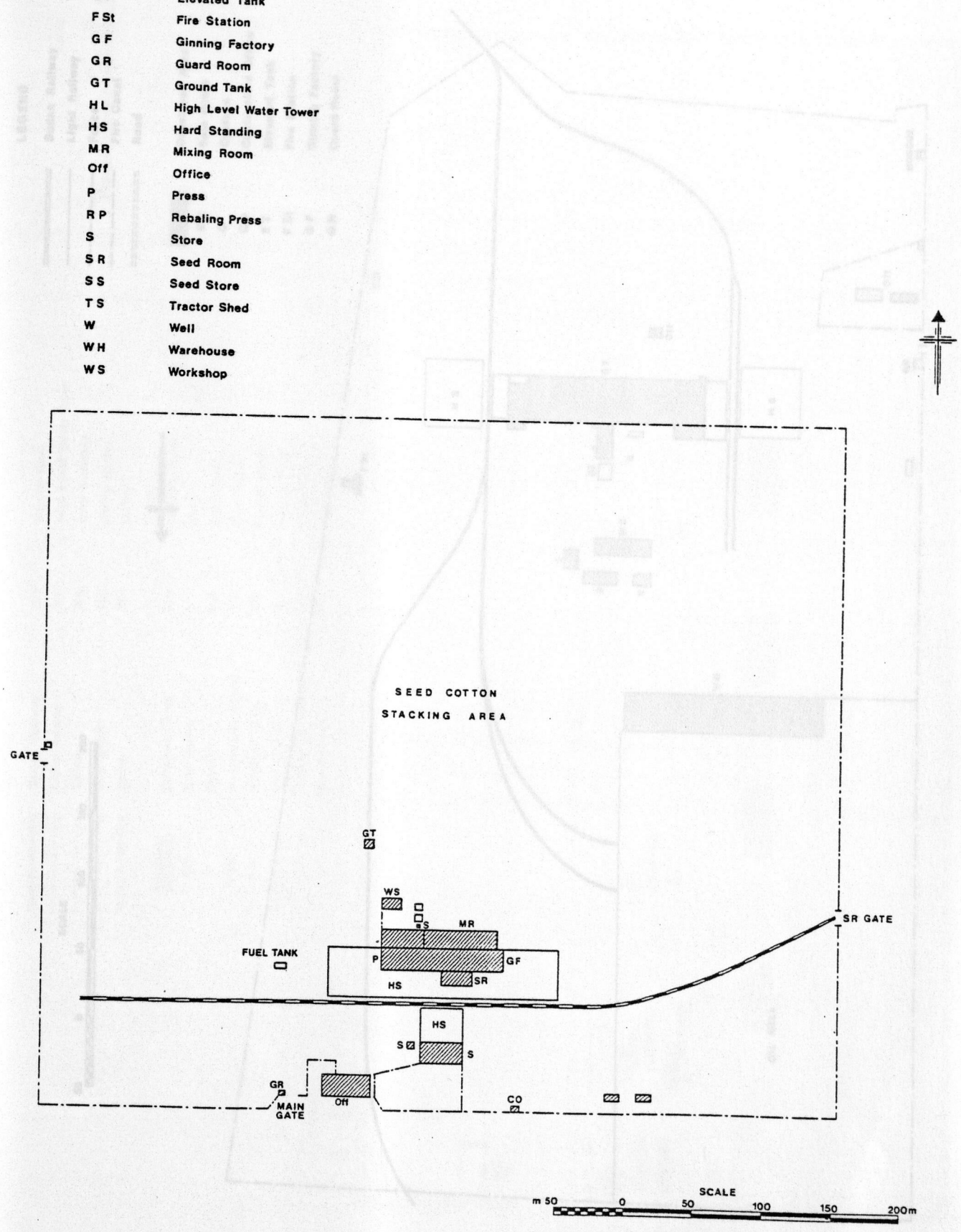


Figure 9

# Rabak Ginnery General Layout

**LEGEND**

- |  |                    |
|--|--------------------|
|  | Sudan Railway      |
|  | Light Railway      |
|  | Fence              |
|  | Fire Canal         |
|  | Road               |
|  | Developed Area     |
|  | Bale Room          |
|  | Cyclone            |
|  | Contractors Office |
|  | Elevated Tank      |
|  | Fire Station       |
|  | Ginning Factory    |
|  | Guard Room         |

- |     |                        |
|-----|------------------------|
| GT  | Ground Tank            |
| HL  | High Level Water Tower |
| HS  | Hard Standing          |
| MR  | Mixing Room            |
| Off | Office                 |
| P   | Press                  |
| RP  | Rebaling Press         |
| S   | Store                  |
| SR  | Seed Room              |
| SS  | Seed Store             |
| TS  | Tractor Shed           |
| W   | Well                   |
| WH  | Warehouse              |
| WS  | Workshop               |

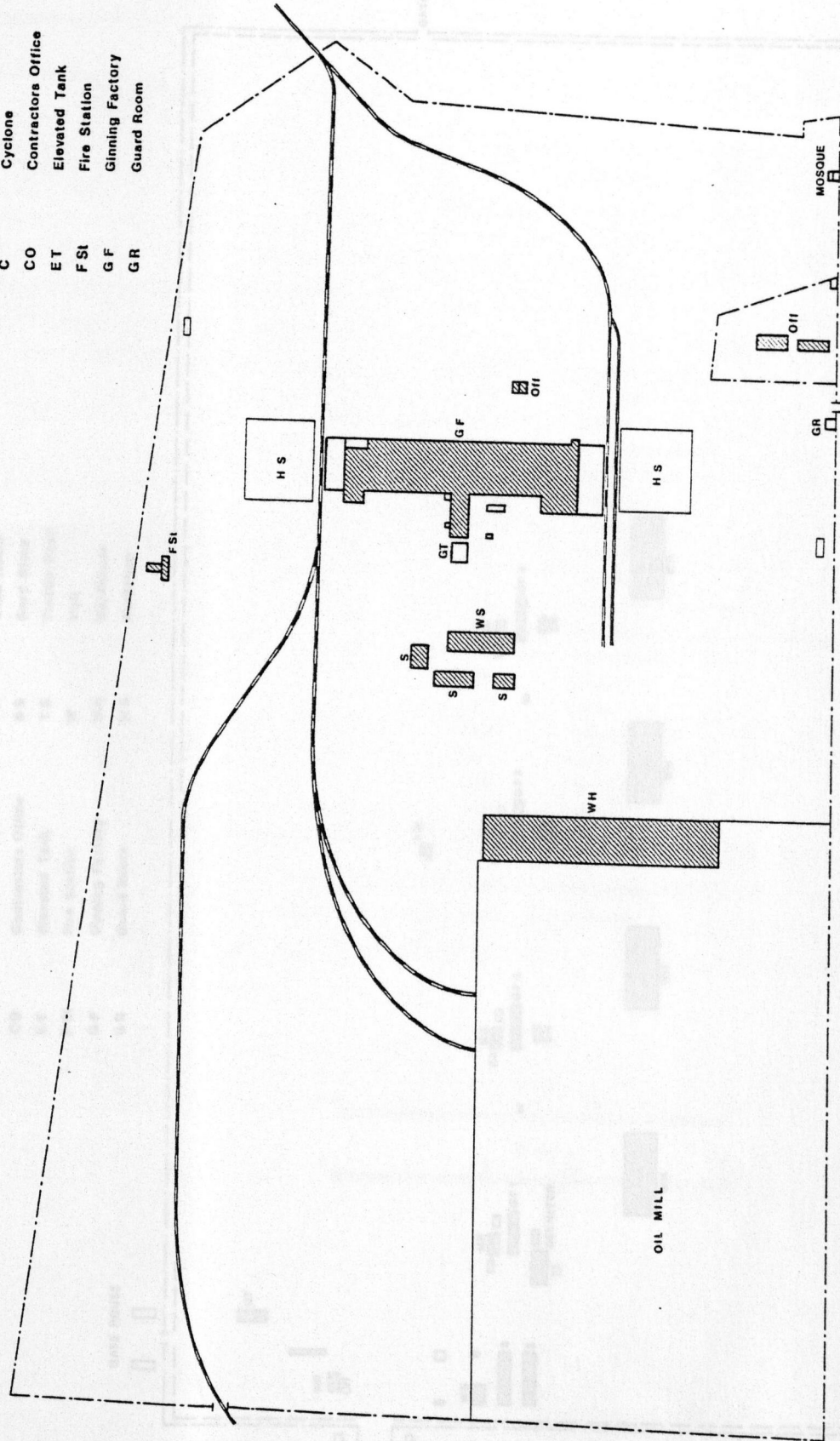
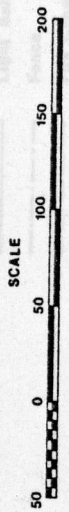
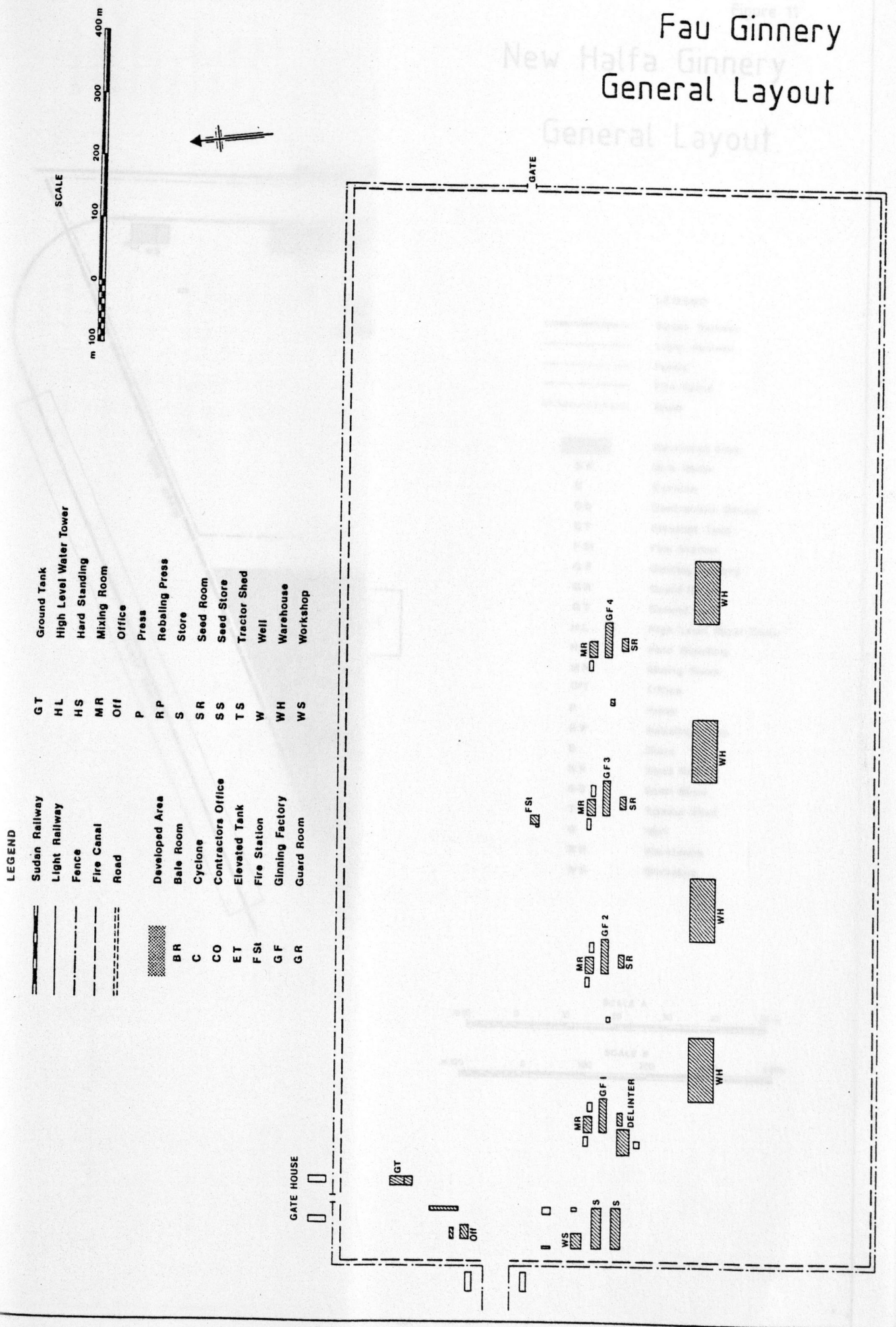


Figure 10

# Fau Ginnery New Halfa Ginnery General Layout

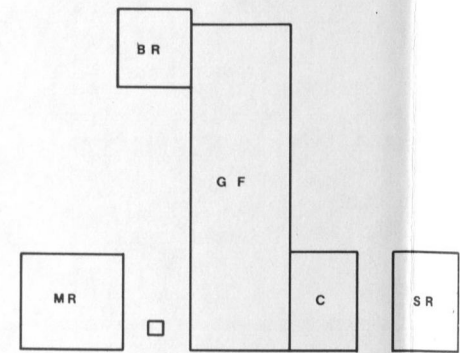
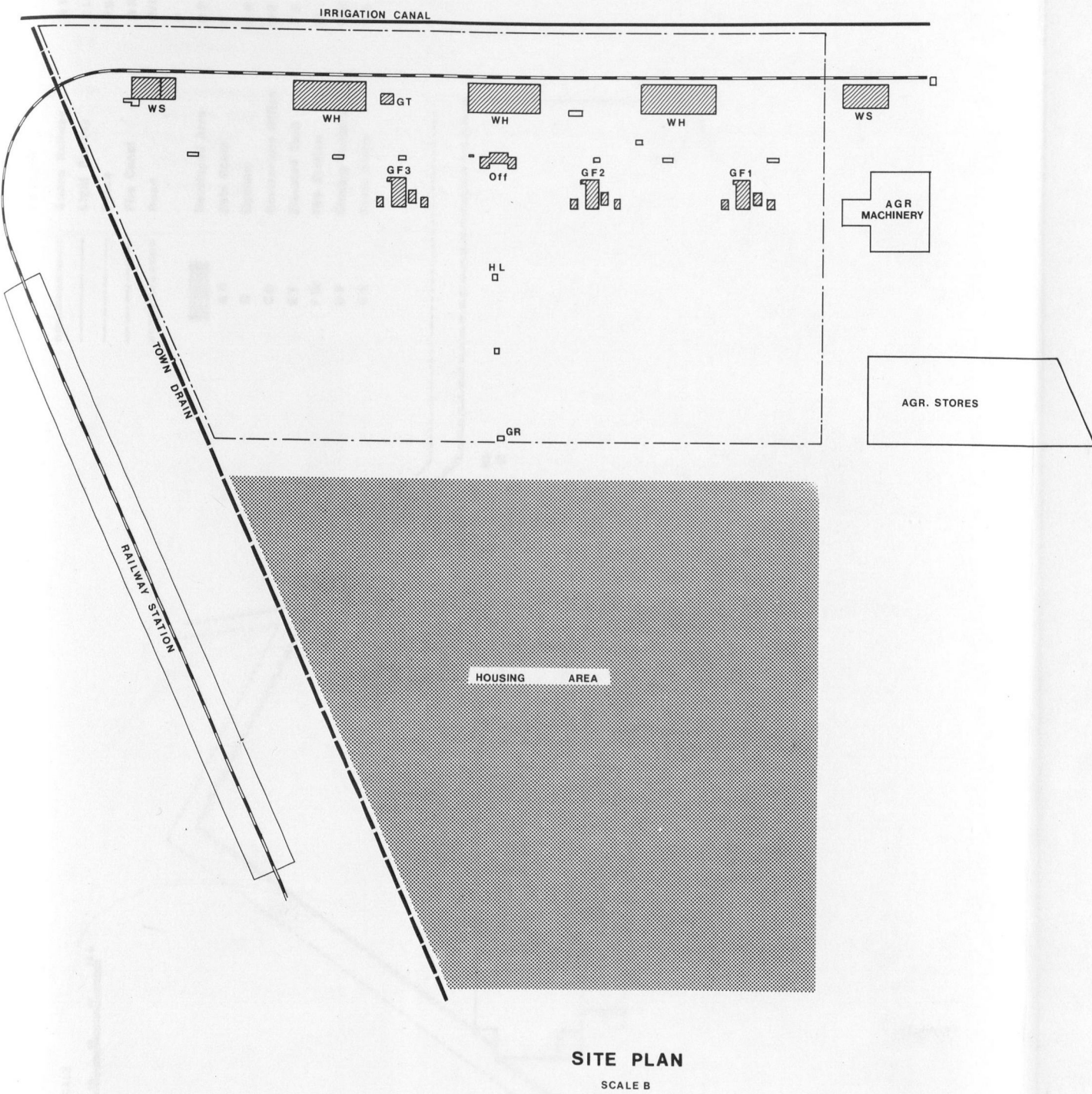


**LEGEND**

- |  |                    |     |                        |
|--|--------------------|-----|------------------------|
|  | Sudan Railway      | GT  | Ground Tank            |
|  | Light Railway      | HL  | High Level Water Tower |
|  | Fence              | HS  | Hard Standing          |
|  | Fire Canal         | MR  | Mixing Room            |
|  | Road               | Off | Office                 |
|  | Developed Area     | P   | Press                  |
|  | Bale Room          | RP  | Rebaling Press         |
|  | Cyclone            | S   | Store                  |
|  | Contractors Office | SR  | Seed Room              |
|  | Elevated Tank      | SS  | Seed Store             |
|  | Fire Station       | TS  | Tractor Shed           |
|  | Ginning Factory    | W   | Well                   |
|  | Guard Room         | WH  | Warehouse              |
|  |                    | WS  | Workshop               |

Figure 11

# New Halfa Ginnery General Layout.



**LEGEND**

	Sudan Railway
	Light Railway
	Fence
	Fire Canal
	Road
	Developed Area
BR	Bale Room
C	Cyclone
CO	Contractors Office
ET	Elevated Tank
FSt	Fire Station
GF	Ginning Factory
GR	Guard Room
GT	Ground Tank
HL	High Level Water Tower
HS	Hard Standing
MR	Mixing Room
Off	Office
P	Press
RP	Rebaling Press
S	Store
SR	Seed Room
SS	Seed Store
TS	Tractor Shed
W	Well
WH	Warehouse
WS	Workshop

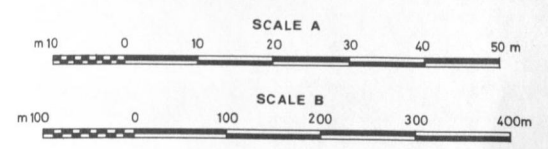

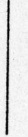
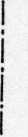
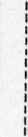









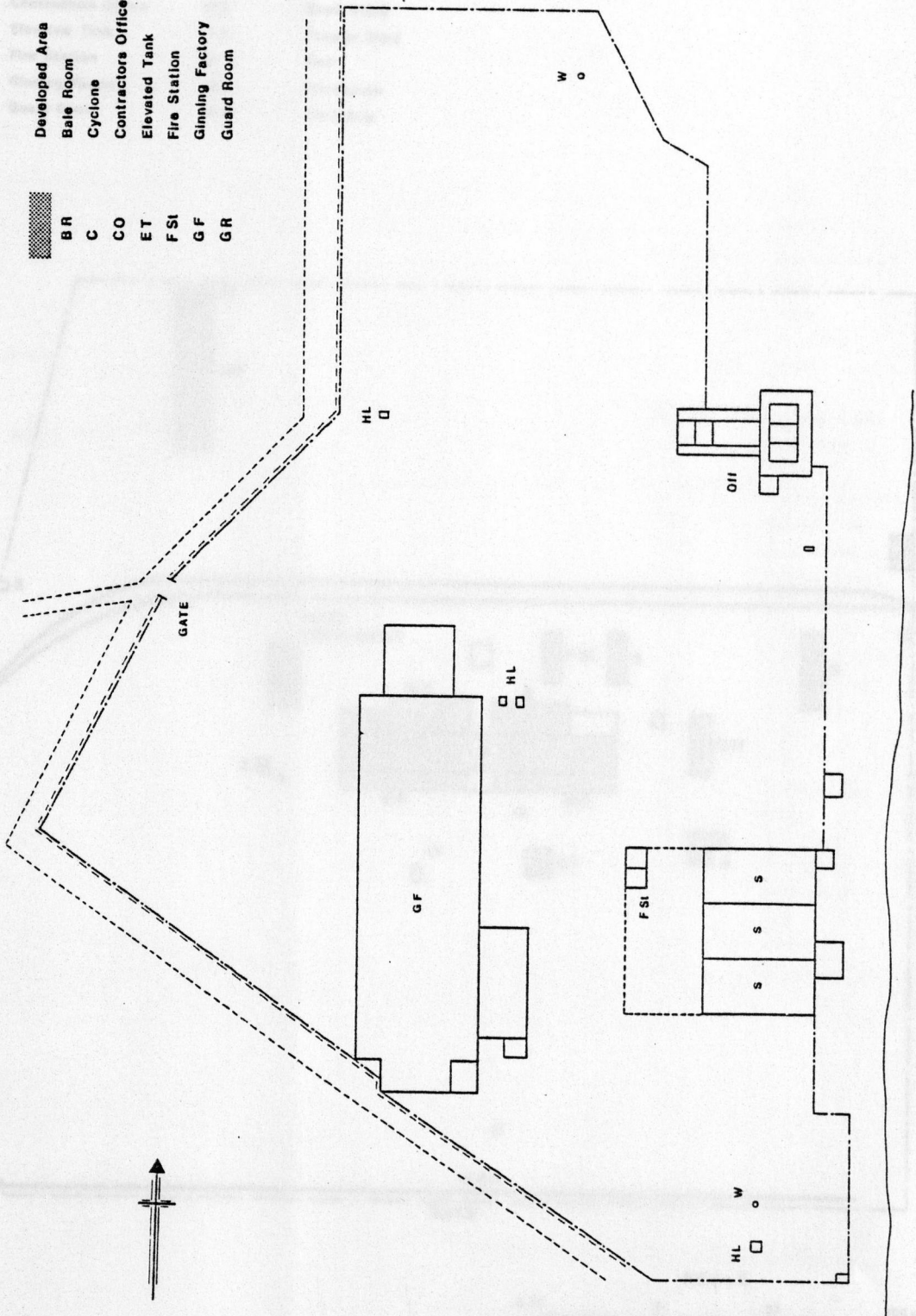


Figure 12

# Zeidab Ginnery General Layout

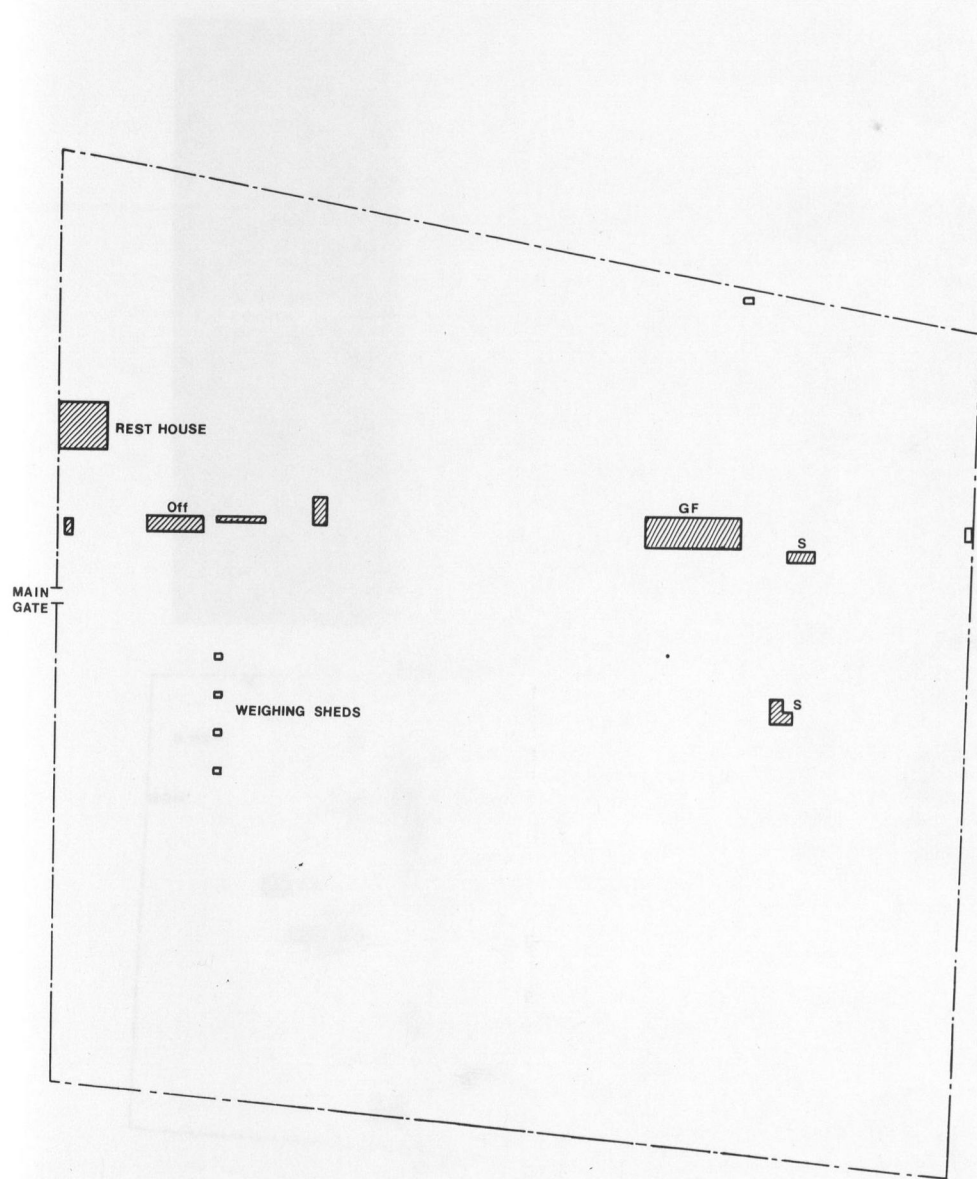
**LEGEND**

- |   |                    |     |                        |
|---|--------------------|-----|------------------------|
|  | Sudan Railway      | GT  | Ground Tank            |
|  | Light Railway      | HL  | High Level Water Tower |
|  | Fence              | HS  | Hard Standing          |
|  | Fire Canal         | MR  | Mixing Room            |
|  | Road               | Off | Office                 |
|  | Developed Area     | P   | Press                  |
|  | Bale Room          | RP  | Rebaling Press         |
|  | Cyclone            | S   | Store                  |
|  | Contractors Office | SR  | Seed Room              |
|  | Elevated Tank      | SS  | Seed Store             |
|  | Fire Station       | TS  | Tractor Shed           |
|  | Ginning Factory    | W   | Well                   |
|  | Guard Room         | WH  | Warehouse              |
|   |                    | WS  | Workshop               |

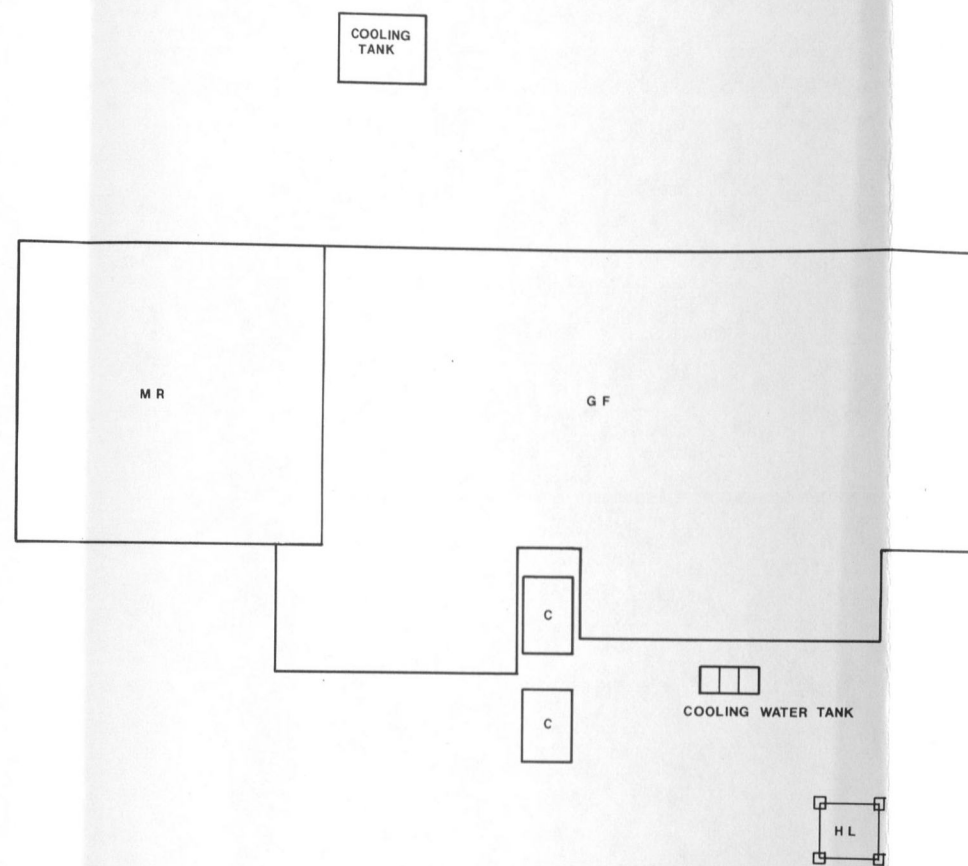




# Kadugli Ginnery General Layout



**SITE PLAN**  
SCALE B

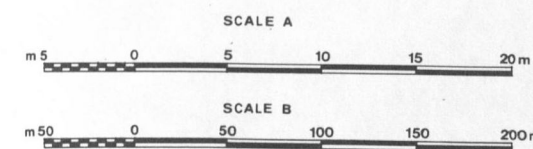


**PLAN OF GINNERY**  
SCALE A

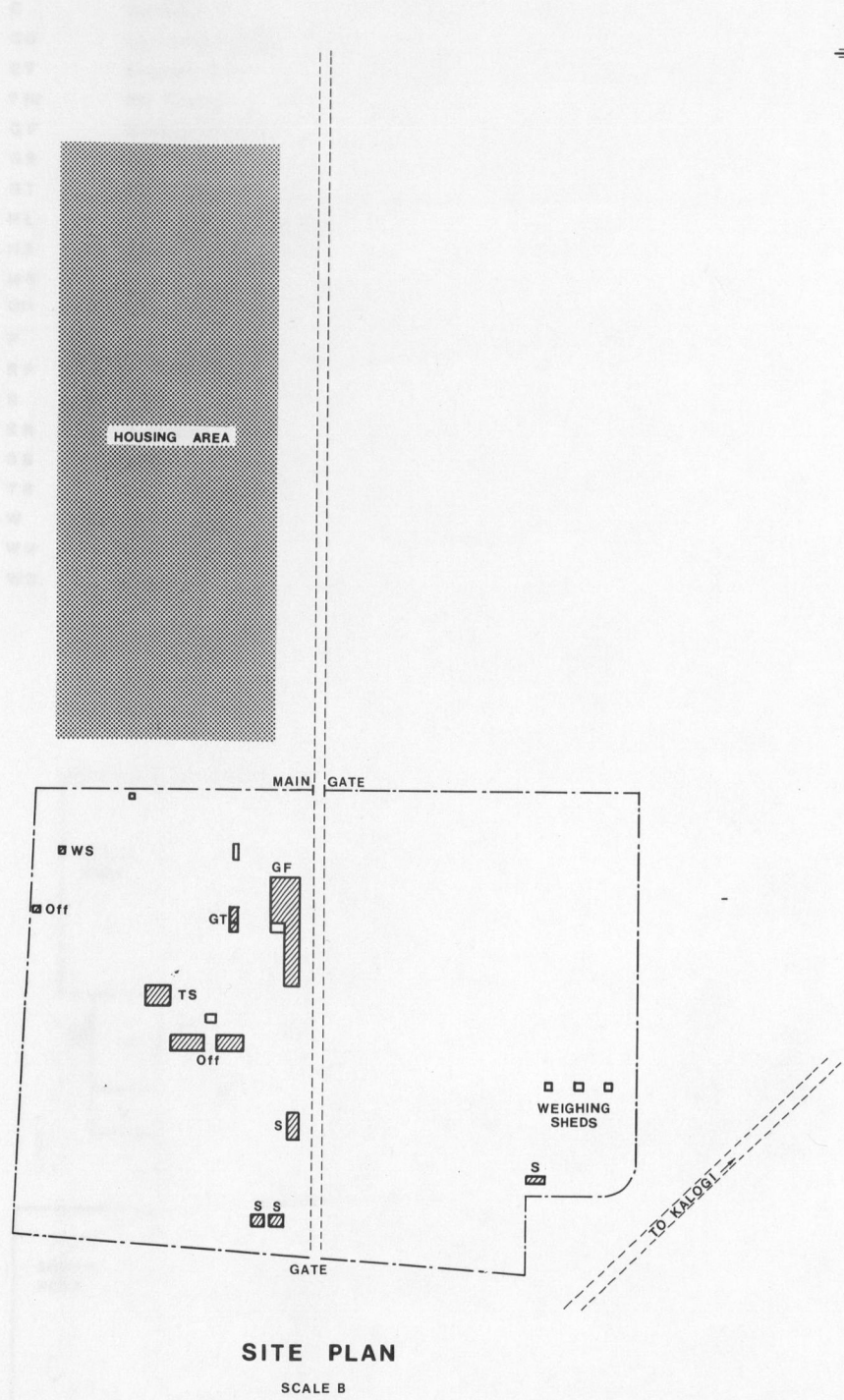
**LEGEND**

	Sudan Railway
	Light Railway
	Fence
	Fire Canal
	Road
	Developed Area
BR	Bale Room
C	Cyclone
CO	Contractors Office
ET	Elevated Tank
FSt	Fire Station
GF	Ginning Factory
GR	Guard Room
GT	Ground Tank
HL	High Level Water Tower
HS	Hard Standing
MR	Mixing Room
Off	Office
P	Press
RP	Rebaling Press
S	Store
SR	Seed Room
SS	Seed Store
TS	Tractor Shed
W	Well
WH	Warehouse
WS	Workshop

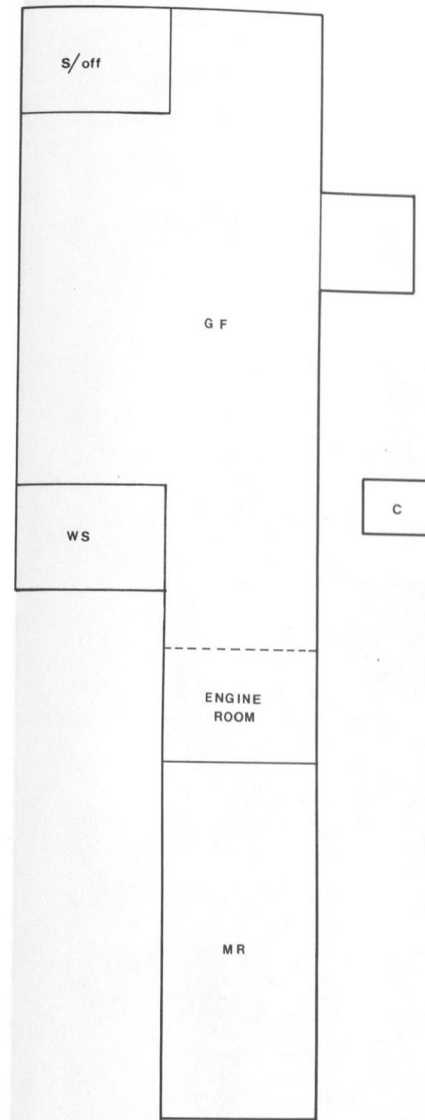
OW



# Talodi Ginnery General Layout



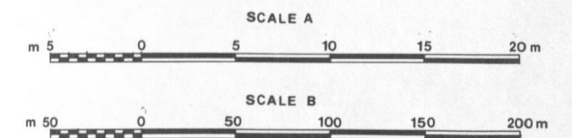
**SITE PLAN**  
SCALE B



**PLAN OF GINNERY**  
SCALE A

**LEGEND**

	Sudan Railway
	Light Railway
	Fence
	Fire Canal
	Road
	Developed Area
<b>BR</b>	Bale Room
<b>C</b>	Cyclone
<b>CO</b>	Contractors Office
<b>ET</b>	Elevated Tank
<b>FSt</b>	Fire Station
<b>GF</b>	Ginning Factory
<b>GR</b>	Guard Room
<b>GT</b>	Ground Tank
<b>HL</b>	High Level Water Tower
<b>HS</b>	Hard Standing
<b>MR</b>	Mixing Room
<b>Off</b>	Office
<b>P</b>	Press
<b>RP</b>	Rebaling Press
<b>S</b>	Store
<b>SR</b>	Seed Room
<b>SS</b>	Seed Store
<b>TS</b>	Tractor Shed
<b>W</b>	Well
<b>WH</b>	Warehouse
<b>WS</b>	Workshop

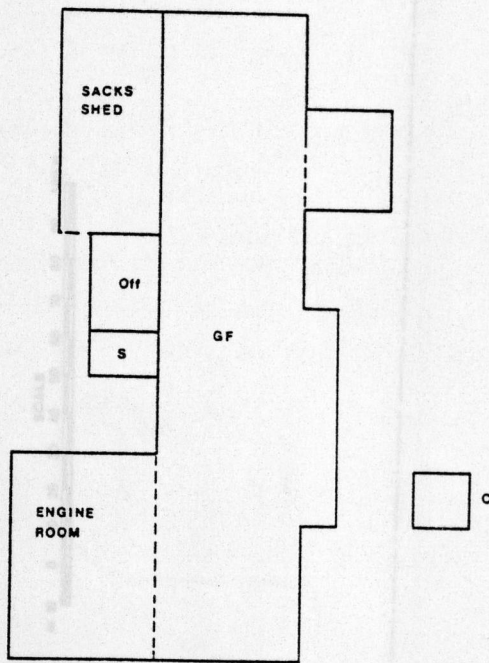


# Kologi Ginnery General Layout

**LEGEND**

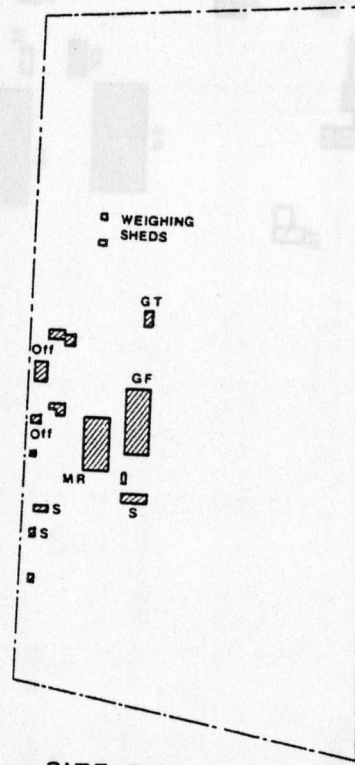
	Sudan Railway
	Light Railway
	Fence
	Fire Canal
	Road

	Developed Area
BR	Bale Room
C	Cyclone
CO	Contractors Office
ET	Elevated Tank
FSt	Fire Station
GF	Ginning Factory
GR	Guard Room
GT	Ground Tank
HL	High Level Water Tower
HS	Hard Standing
MR	Mixing Room
Off	Office
P	Press
RP	Rebaling Press
S	Store
SR	Seed Room
SS	Seed Store
TS	Tractor Shed
W	Well
WH	Warehouse
WS	Workshop



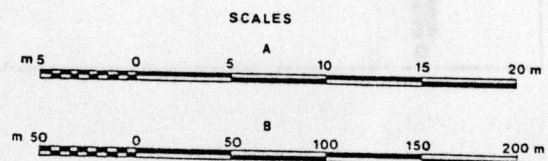
**PLAN OF GINNERY**

SCALE A



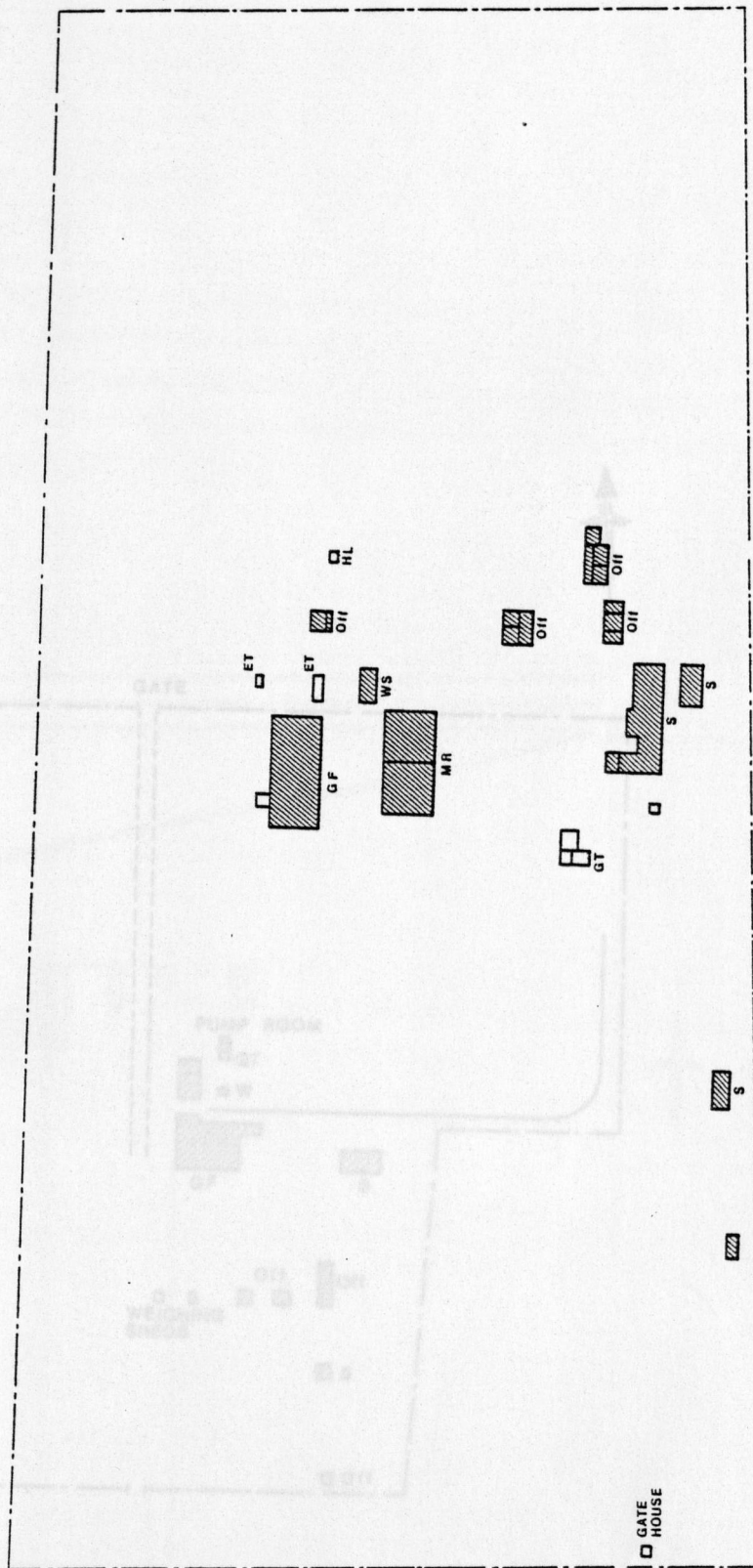
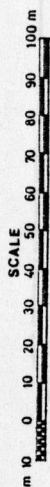
**SITE PLAN**

SCALE B



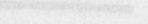
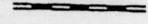
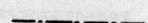
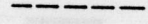


# Abu Gebeiha Ginnery General Layout

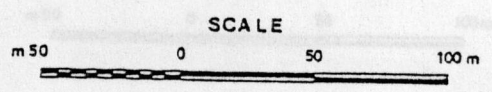
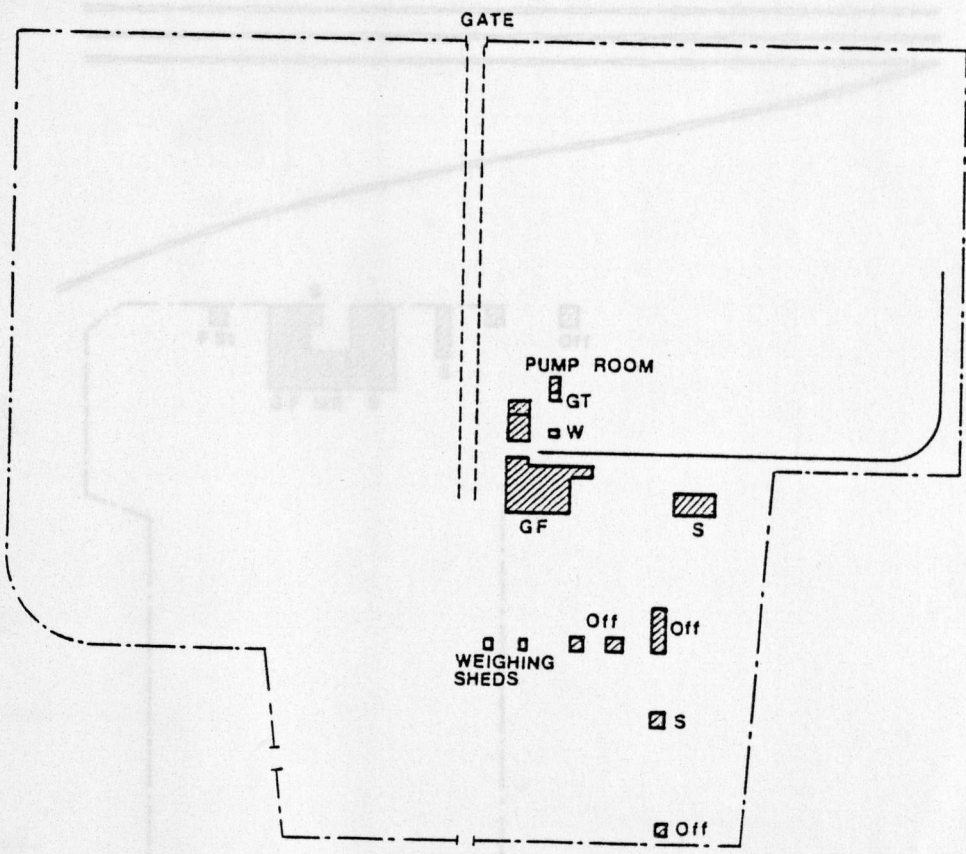
<b>LEGEND</b>	Ground Tank GT
Sudan Railway Light Railway	High Level Water Tower HL
Fence	Hard Standing HS
Fire Canal	Mixing Room MR
Road	Office Off
Developed Area	Press P
Bale Room Cyclone Contractors Office Elevated Tank Fire Station Ginning Factory Guard Room	Rebaling Press Store Seed Room Seed Store Tractor Shed Well Warehouse Workshop
BR C CO ET FSt GF GR	RP S SR SS TS W WH WS




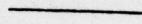
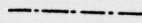

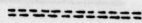

# Umm Berembeita Ginnery General Layout

LEGEND

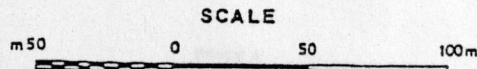
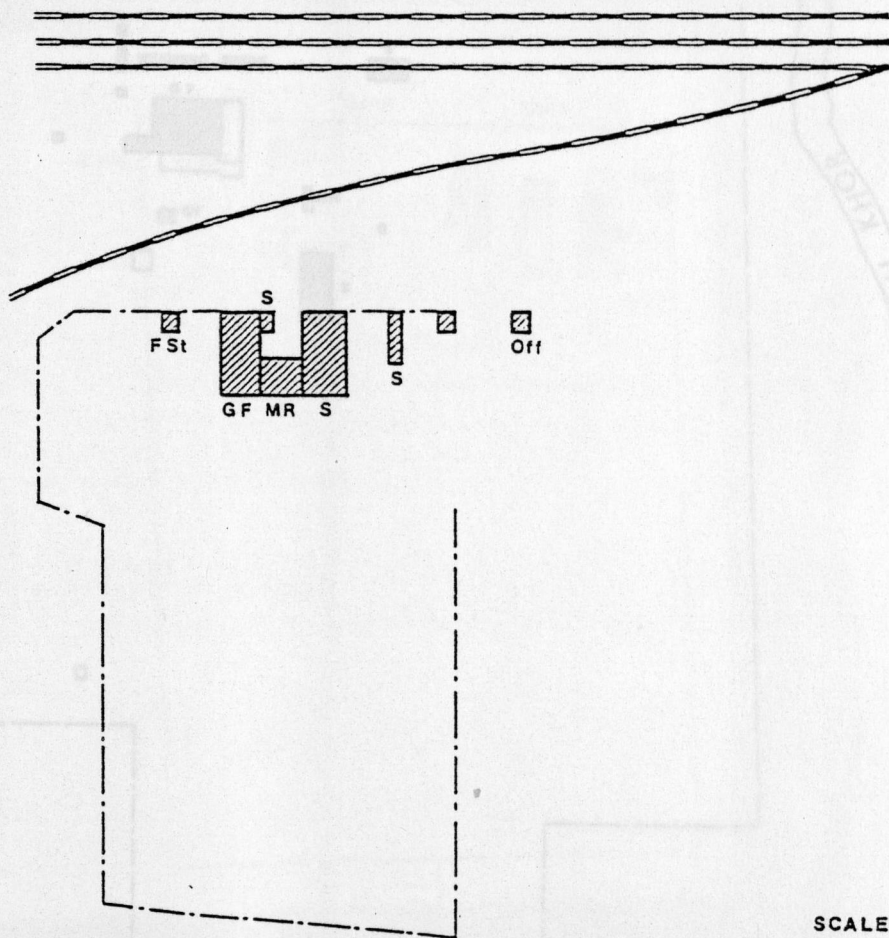
	Sudan Railway
	Light Railway
	Fence
	Fire Canal
	Road
	Developed Area
BR	Bale Room
C	Cyclone
CO	Contractors Office
ET	Elevated Tank
FSt	Fire Station
GF	Ginning Factory
GR	Guard Room
GT	Ground Tank
HL	High Level Water Tower
HS	Hard Standing
MR	Mixing Room
Off	Office
P	Press
RP	Rebaling Press
S	Store
SR	Seed Room
SS	Seed Store
TS	Tractor Shed
W	Well
WH	Warehouse
WS	Workshop



# Semeih Ginnery General Layout

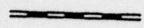
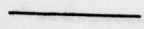
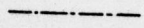
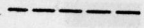
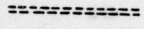

LEGEND	
	Sudan Railway
	Light Railway
	Fence
	Fire Canal
	Road
	Developed Area
BR	Bale Room
C	Cyclone
CO	Contractors Office
ET	Elevated Tank
FSt	Fire Station
GF	Ginning Factory
GR	Guard Room
GT	Ground Tank
HL	High Level Water Tower
HS	Hard Standing
MR	Mixing Room
Off	Office
P	Press
RP	Rebaling Press
S	Store
SR	Seed Room
SS	Seed Store
TS	Tractor Shed
W	Well
WH	Warehouse
WS	Workshop

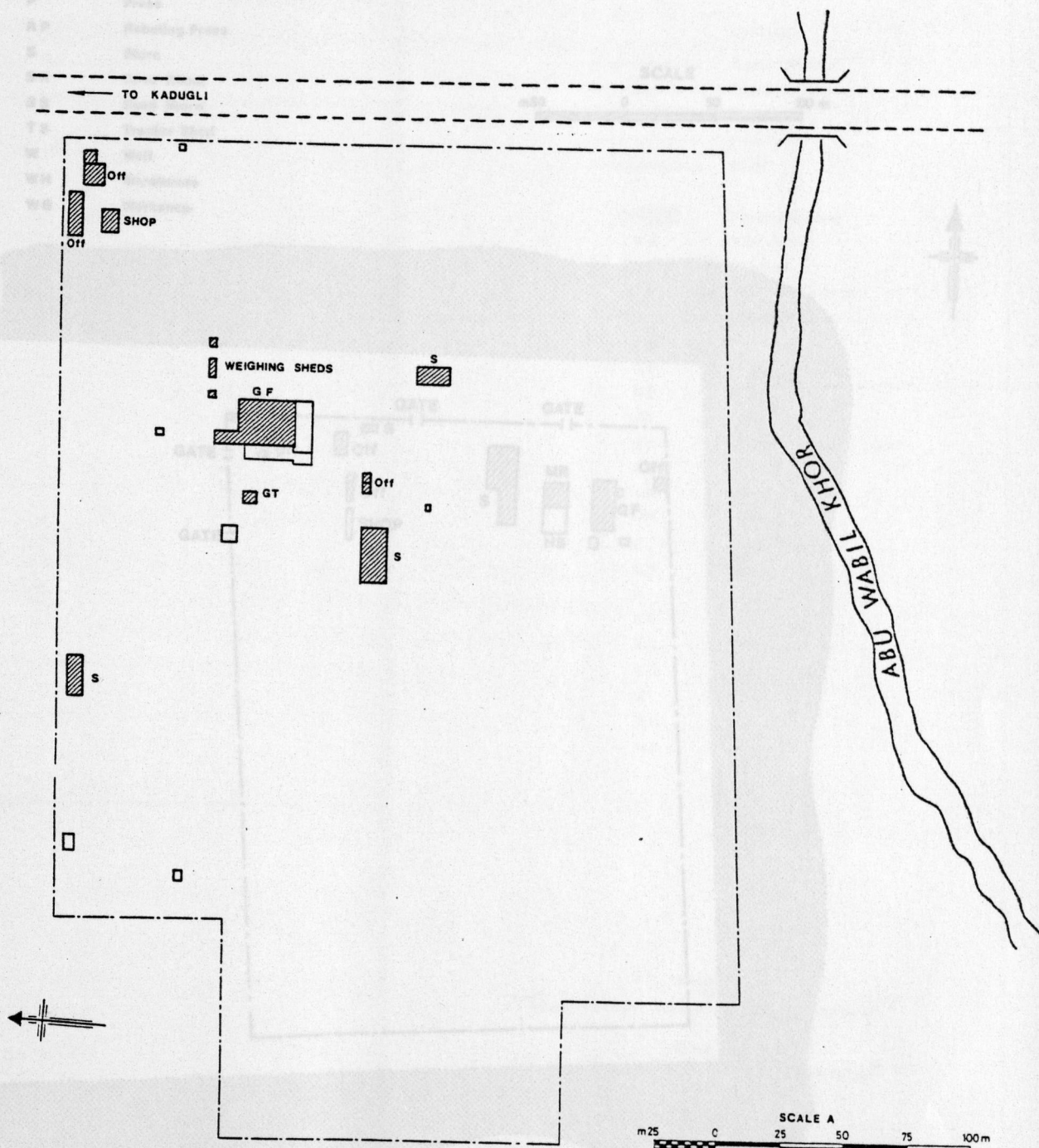
GT	Ground Tank
HL	High Level Water Tower
HS	Hard Standing
MR	Mixing Room
Off	Office
P	Press
RP	Rebaling Press
S	Store
SR	Seed Room
SS	Seed Store
TS	Tractor Shed
W	Well
WH	Warehouse
WS	Workshop



# Dilling Ginnery General Layout


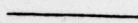
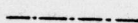

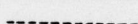

LEGEND

	Sudan Railway	GT	Ground Tank
	Light Railway	HL	High Level Water Tower
	Fence	HS	Hard Standing
	Fire Canal	MR	Mixing Room
	Road	Off	Office
	Developed Area	P	Press
BR	Bale Room	RP	Rebaling Press
C	Cyclone	S	Store
CO	Contractors Office	SR	Seed Room
ET	Elevated Tank	SS	Seed Store
FSt	Fire Station	TS	Tractor Shed
GF	Ginning Factory	W	Well
GR	Guard Room	WH	Warehouse
		WS	Workshop

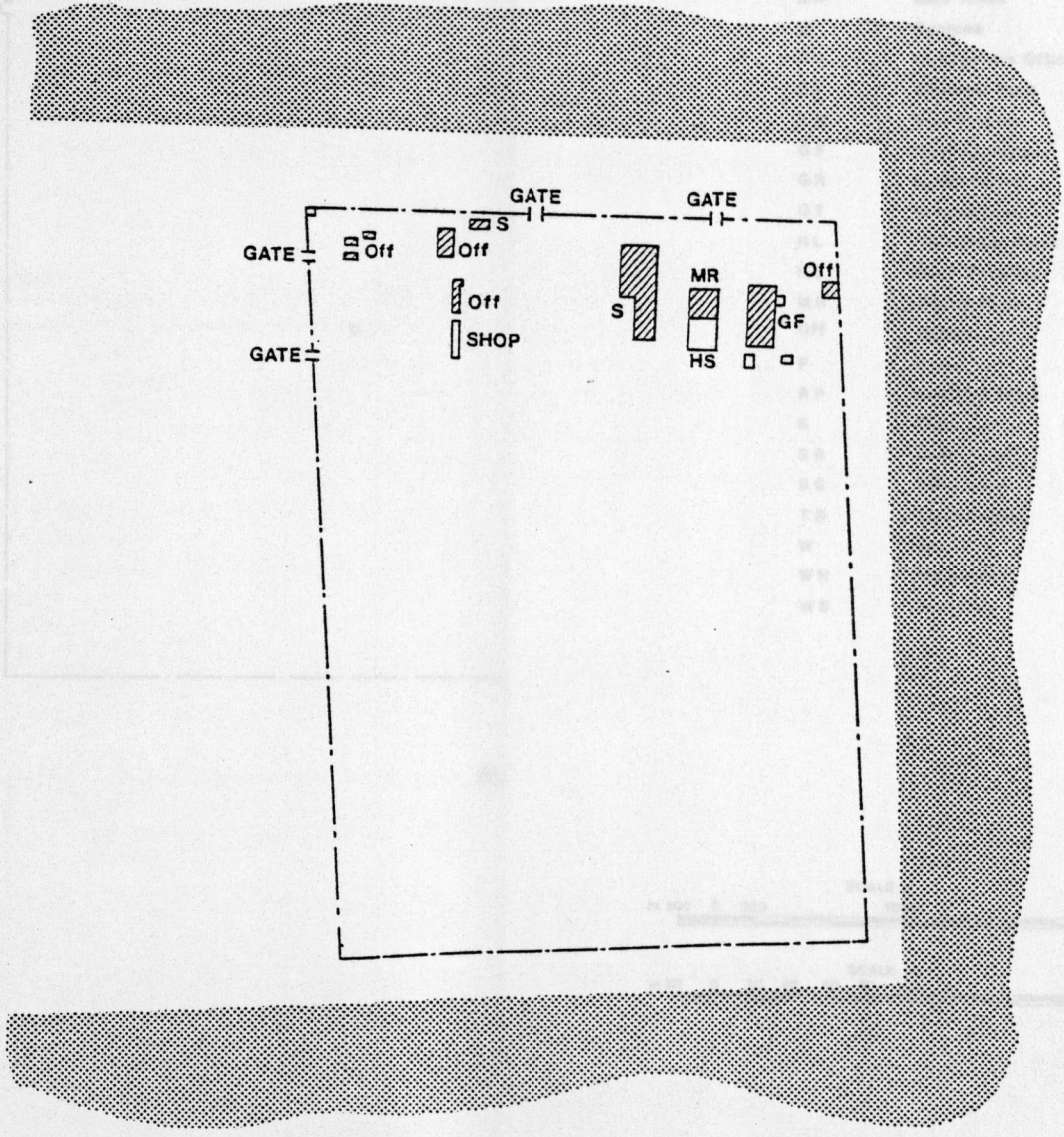
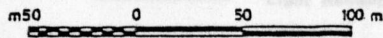


# Lagowa Ginnery General Layout

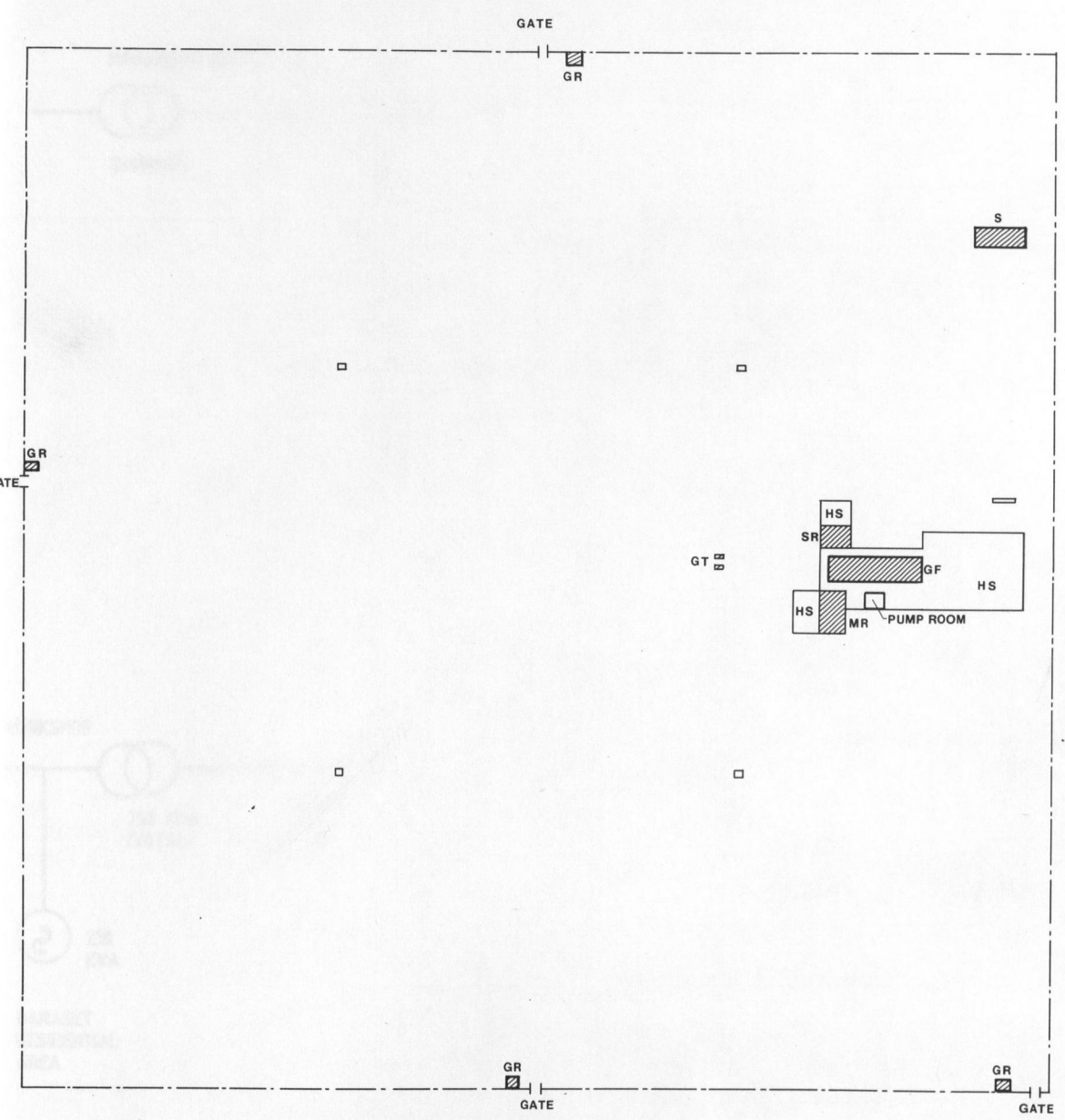
LEGEND

-  Sudan Railway
-  Light Railway
-  Fence
-  Fire Canal
-  Road
  
-  Developed Area
- BR Bale Room
- C Cyclone
- CO Contractors Office
- ET Elevated Tank
- FSt Fire Station
- GF Ginning Factory
- GR Guard Room
- GT Ground Tank
- HL High Level Water Tower
- HS Hard Standing
- MR Mixing Room
- Off Office
- P Press
- RP Rebaling Press
- S Store
- SR Seed Room
- SS Seed Store
- TS Tractor Shed
- W Well
- WH Warehouse
- WS Workshop

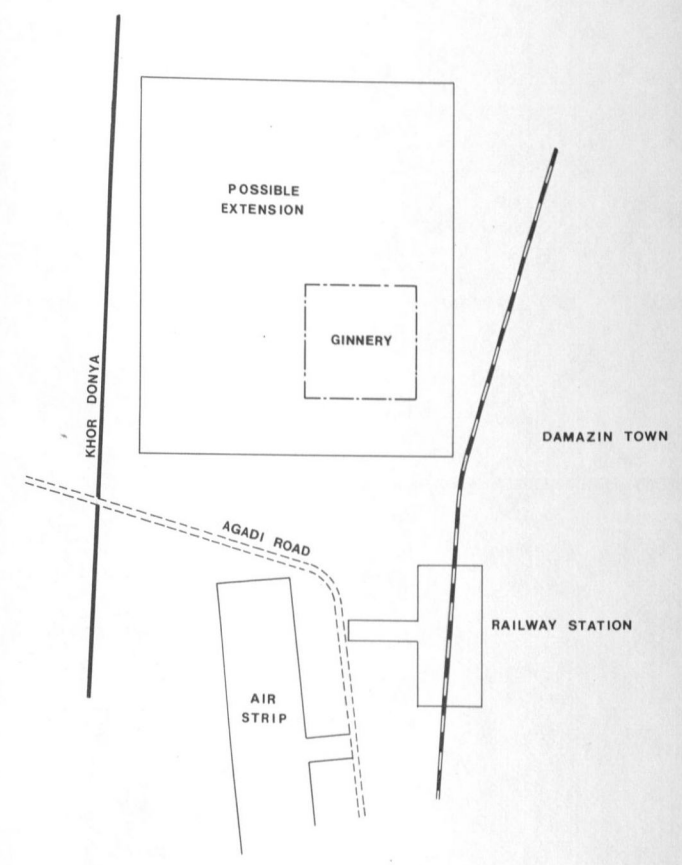
SCALE



# Damazin Ginnery General Layout



**PLAN OF GINNERY**  
SCALE B



**SITE PLAN**  
SCALE A

**LEGEND**

	Sudan Railway
	Light Railway
	Fence
	Fire Canal
	Road
	Developed Area
BR	Bale Room
C	Cyclone
CO	Contractors Office
ET	Elevated Tank
FSt	Fire Station
GF	Ginning Factory
GR	Guard Room
GT	Ground Tank
HL	High Level Water Tower
HS	Hard Standing
MR	Mixing Room
Off	Office
P	Press
RP	Rebaling Press
S	Store
SR	Seed Room
SS	Seed Store
TS	Tractor Shed
W	Well
WH	Warehouse
WS	Workshop

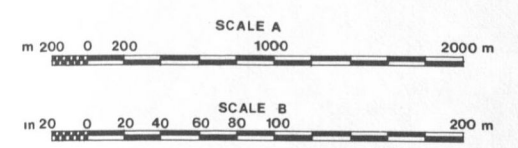


Figure 23.

# Marangan Ginnery Electrical Layout

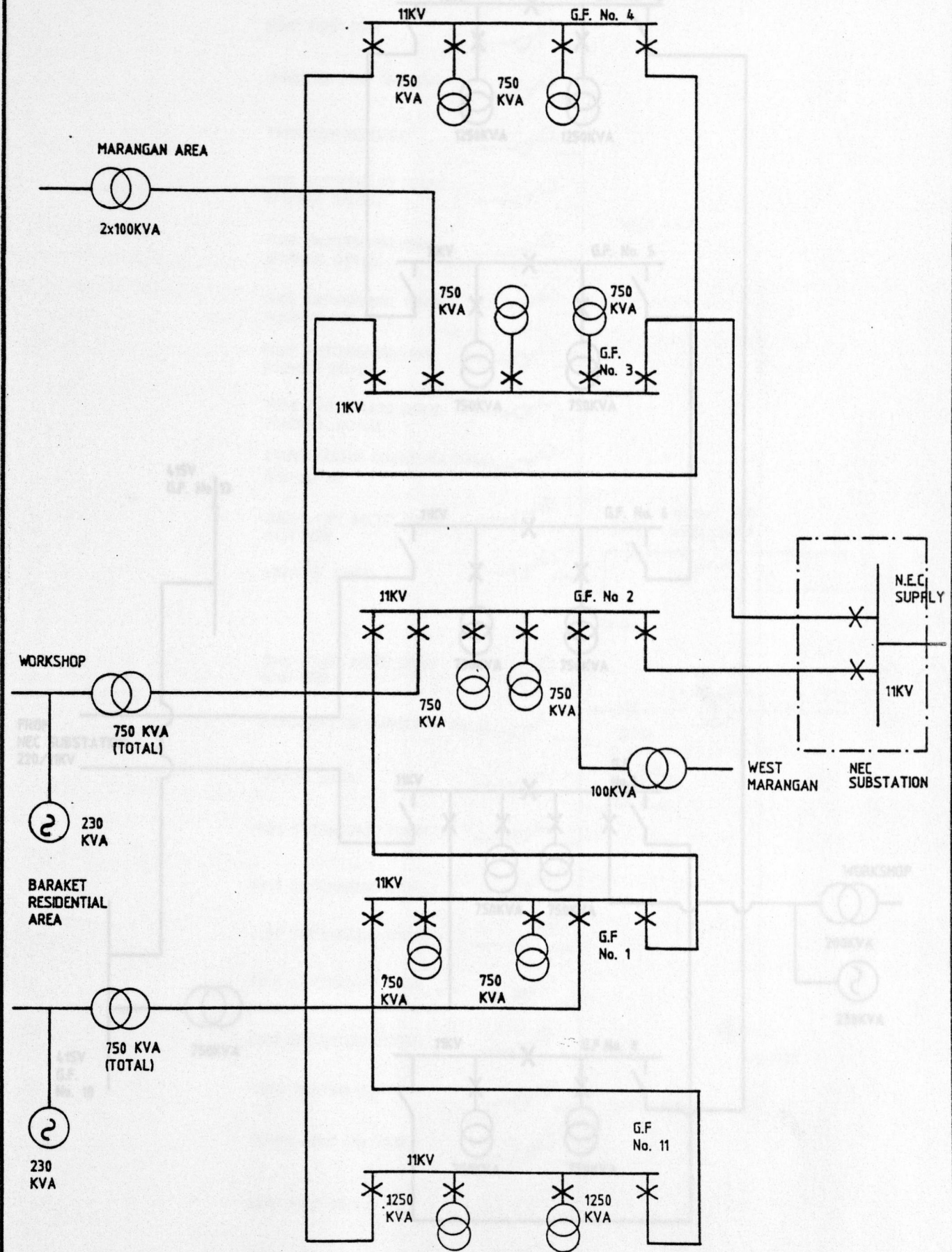
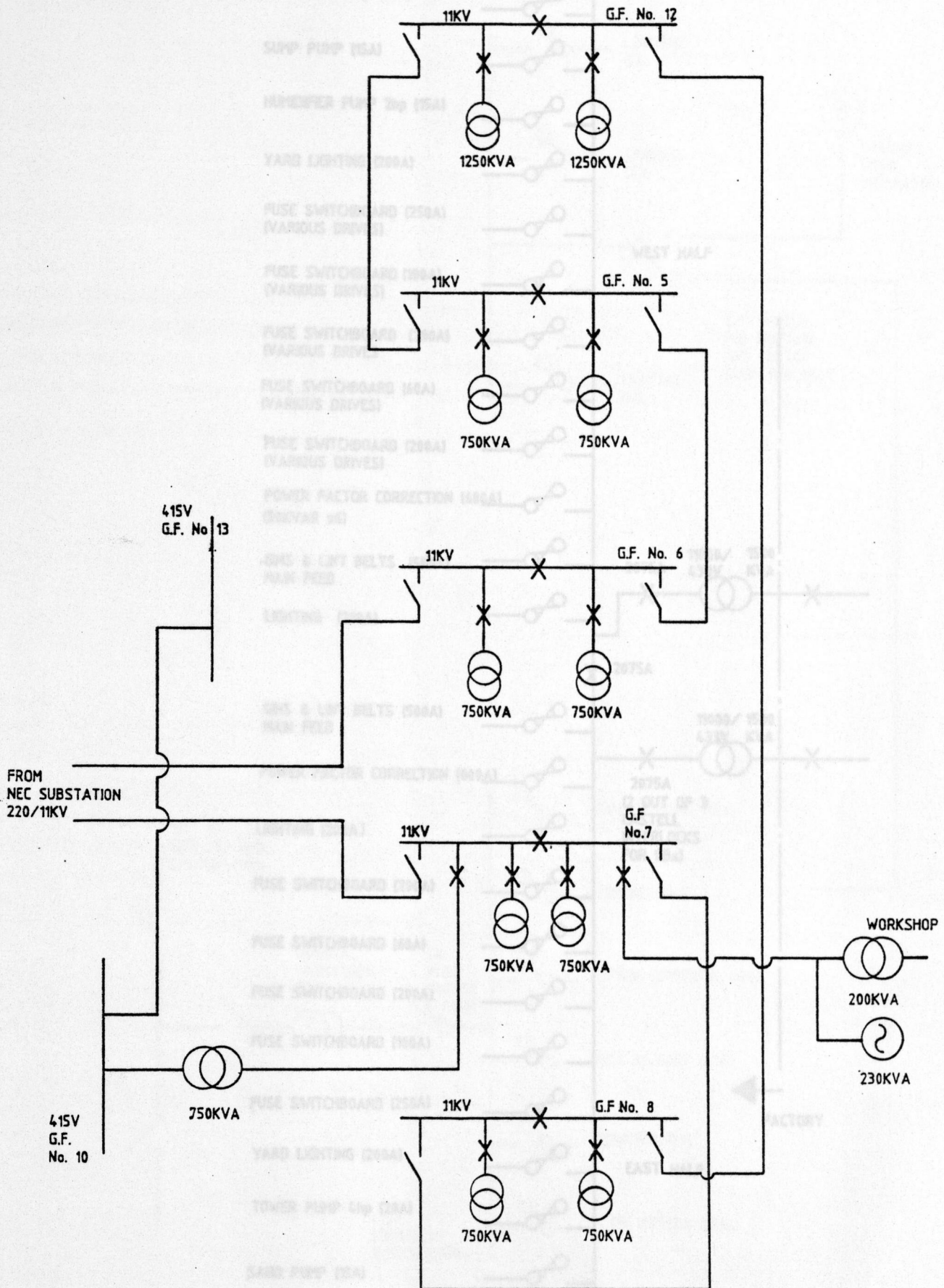


Figure 24

# Hasaheisa Ginnery Electrical Layout



# Bageir Ginnery Electrical Layout

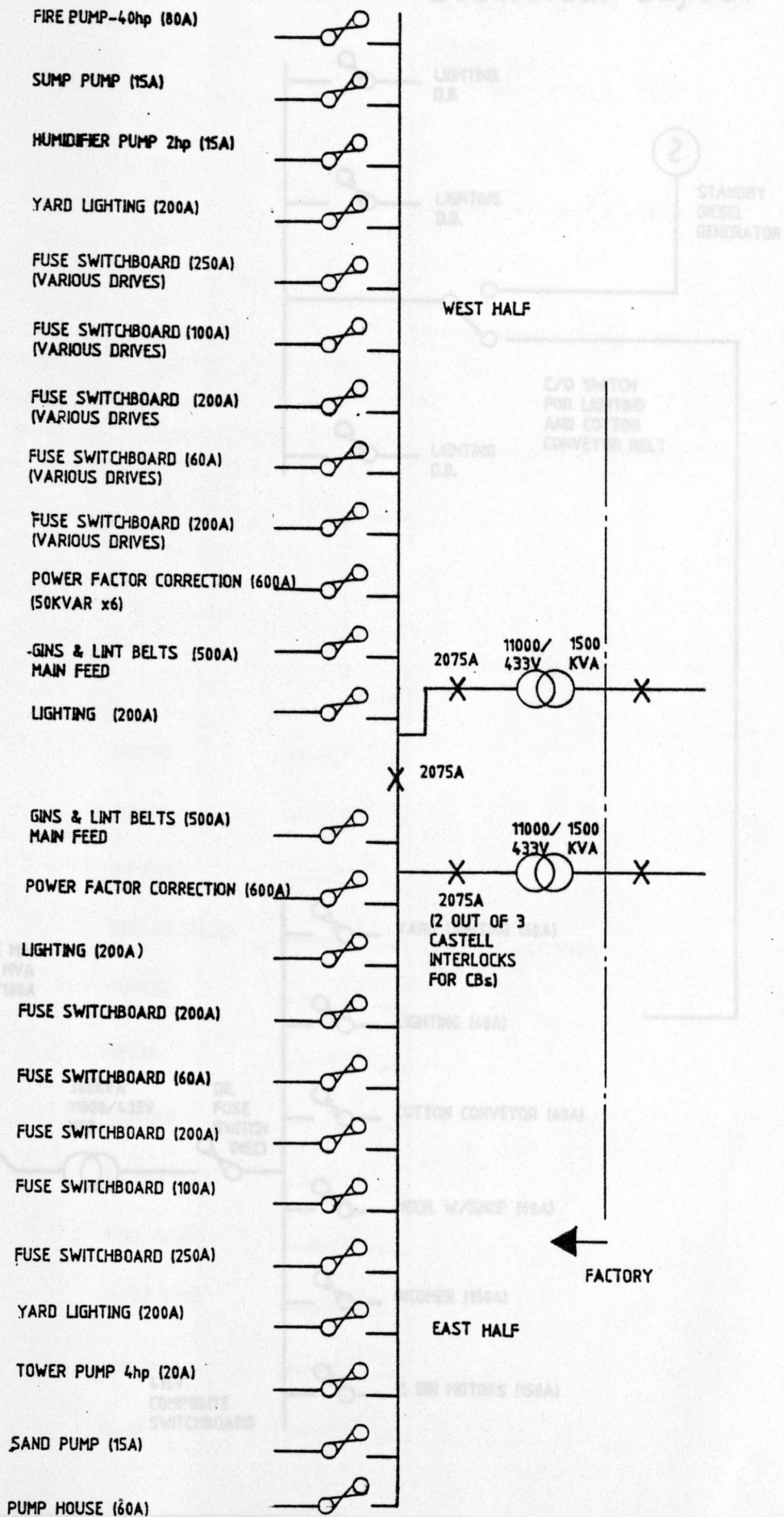
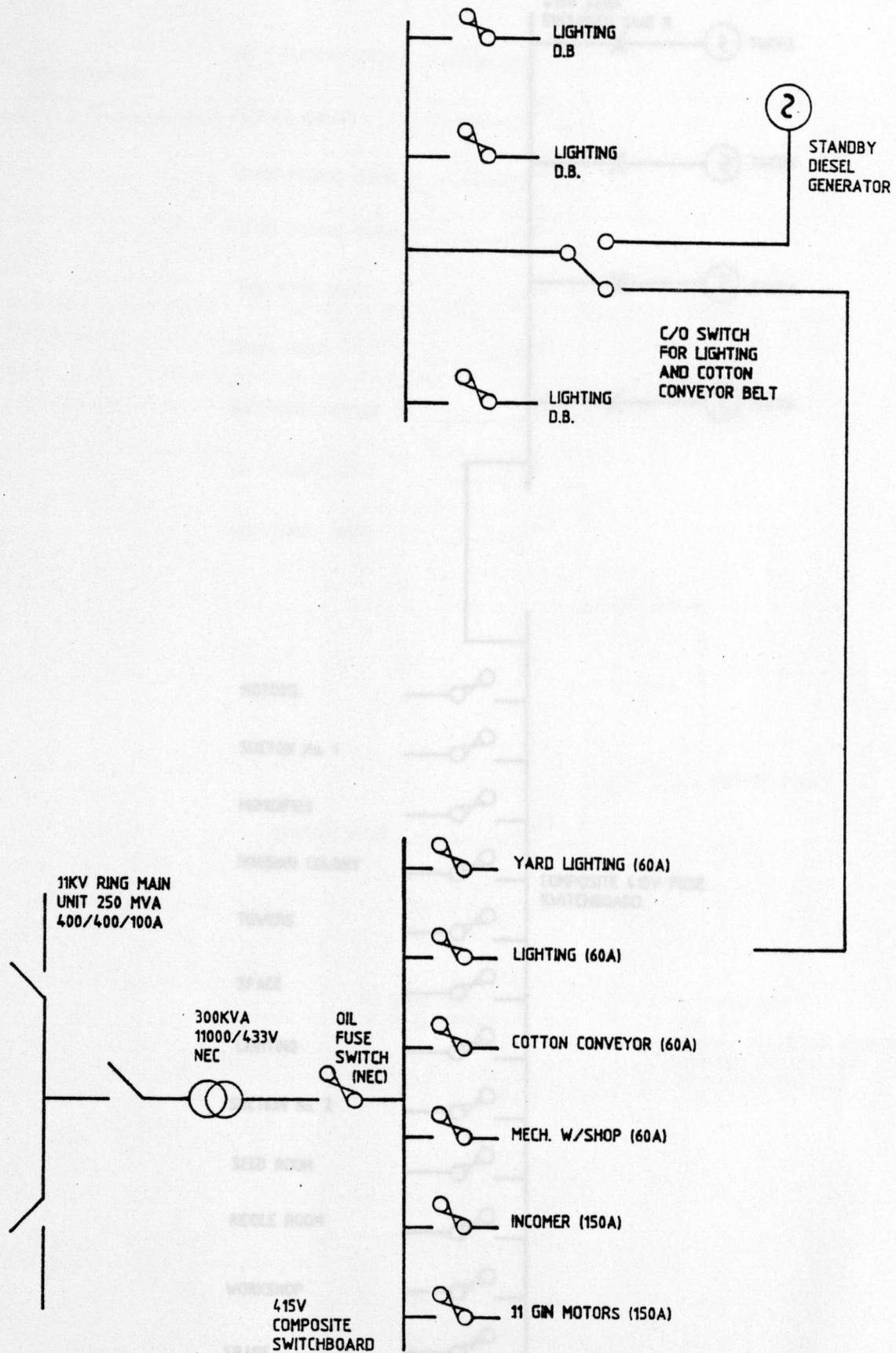
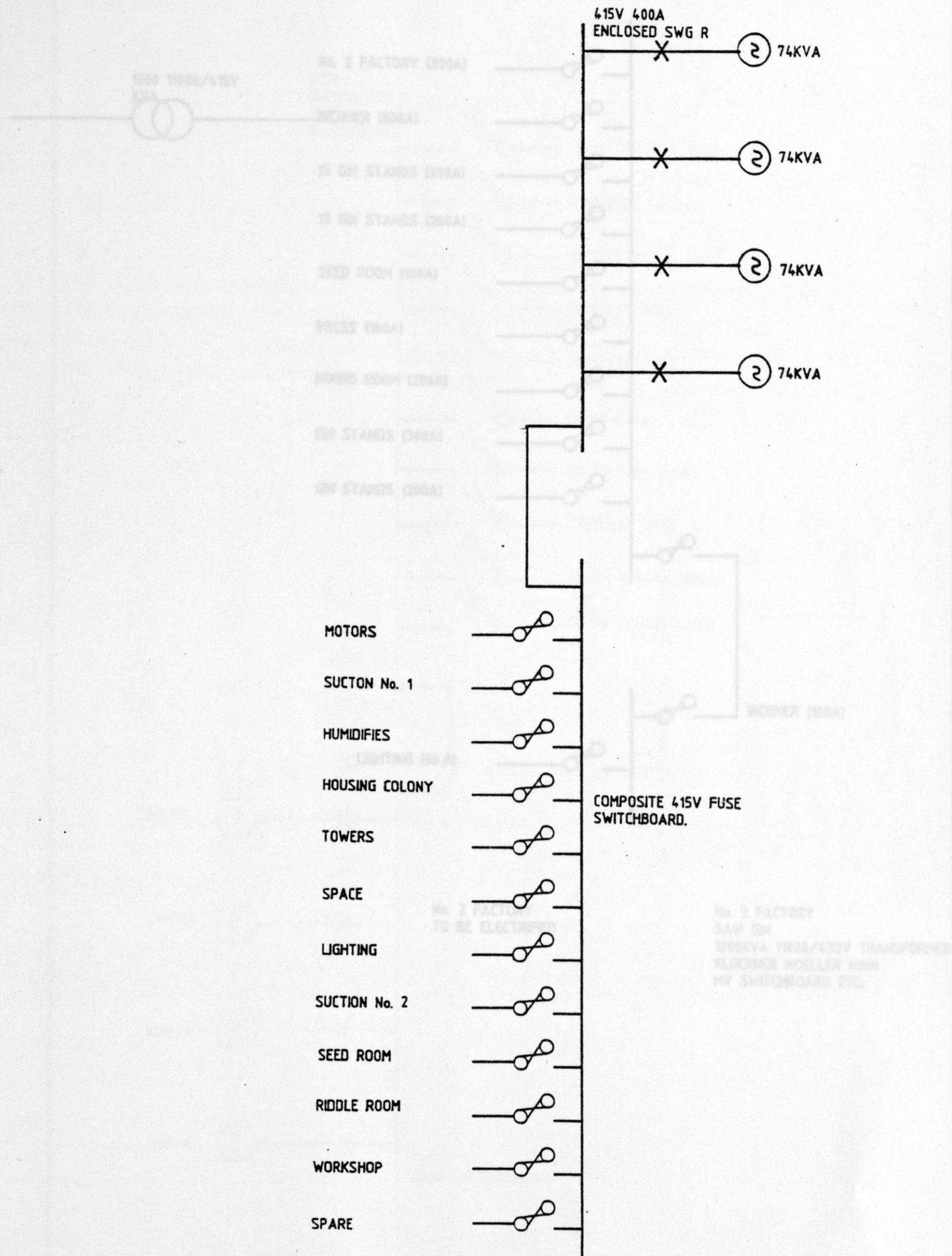


Figure 26

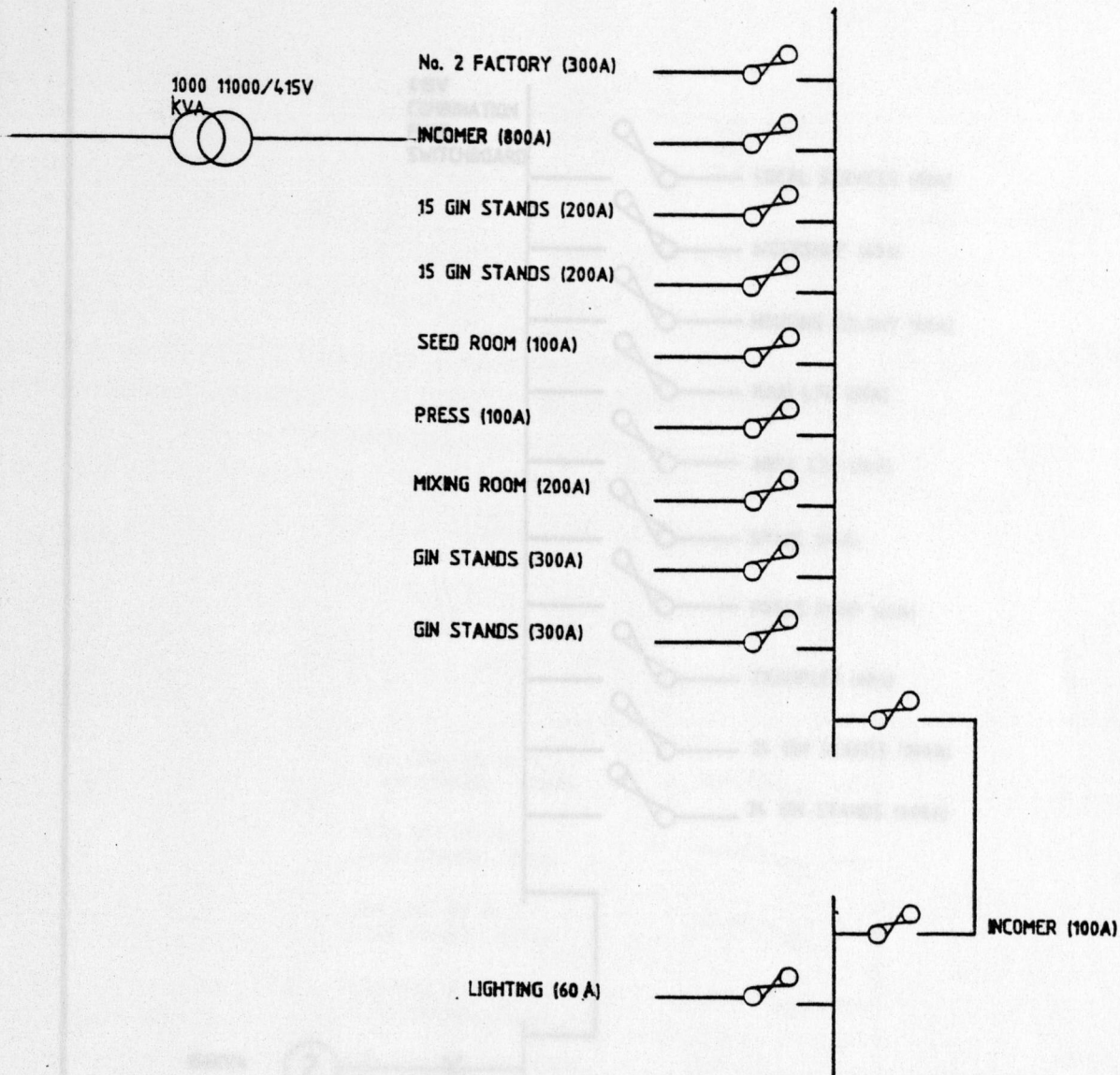
# Sennar Ginnery Electrical Layout



# Hamadnallah Ginnery Electrical Layout



# Kassab Ginnery Electrical Layout



No. 2 FACTORY  
TO BE ELECTRIFIED

No. 3 FACTORY  
SAW GIN  
1000KVA 11000/433V TRANSFORMER  
KLOCKNER MOELLER MAIN  
MV SWITCHBOARD ETC.

# Dueim Ginnery Electrical Layout

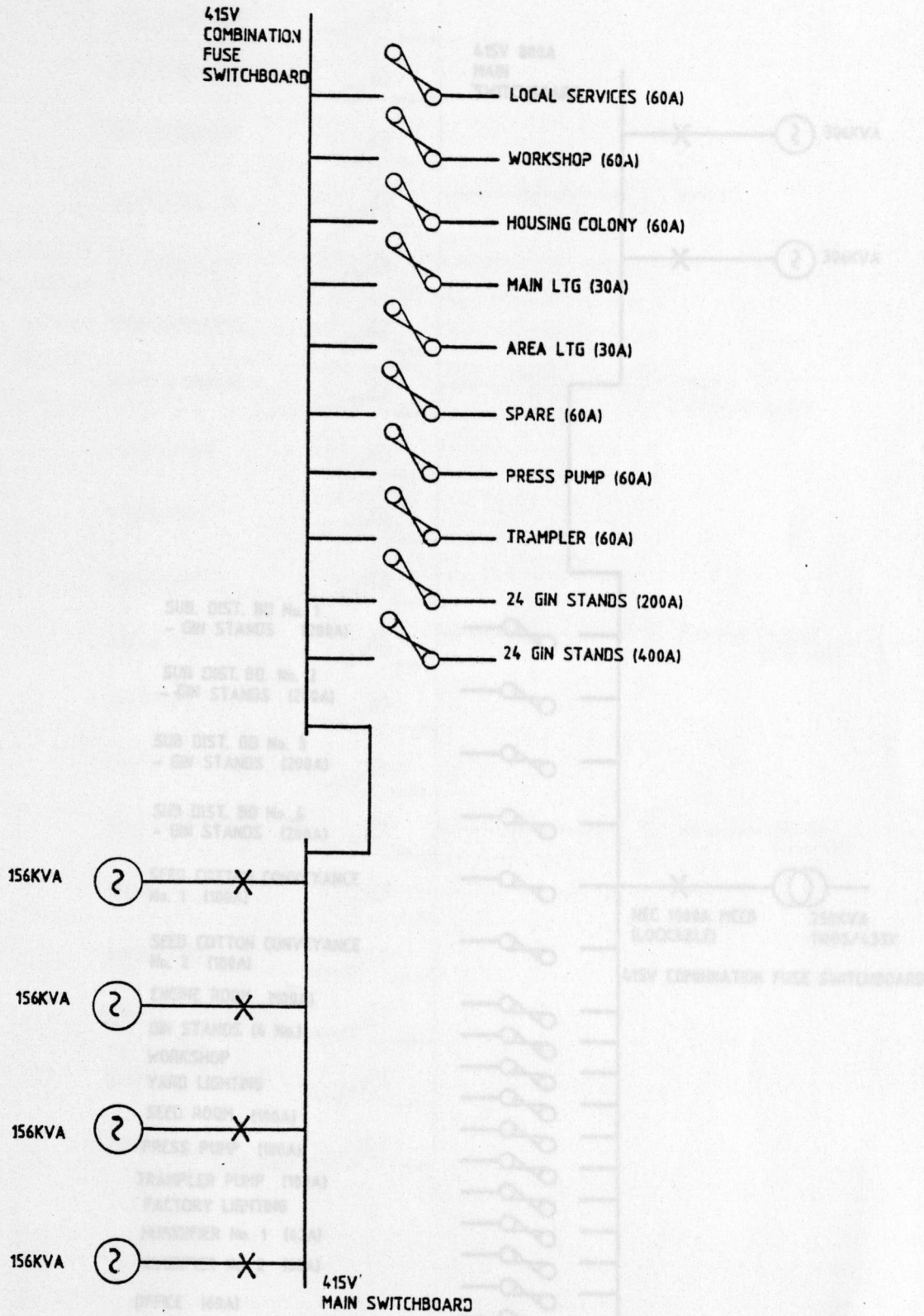


Figure 3 0

# Kosti Ginnery Electrical Layout

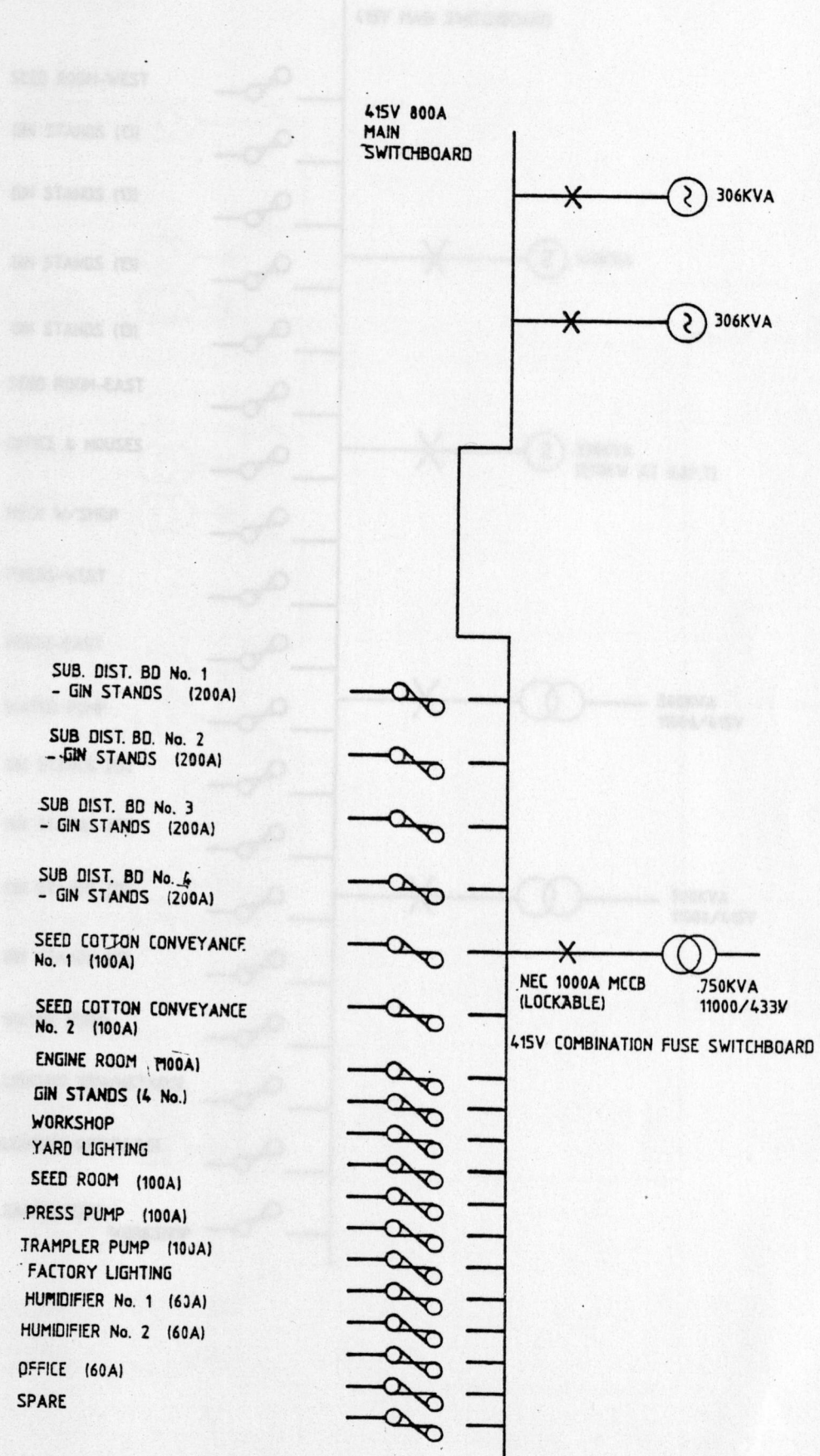


Figure 31.

# Rabak Ginnery Electrical Layout

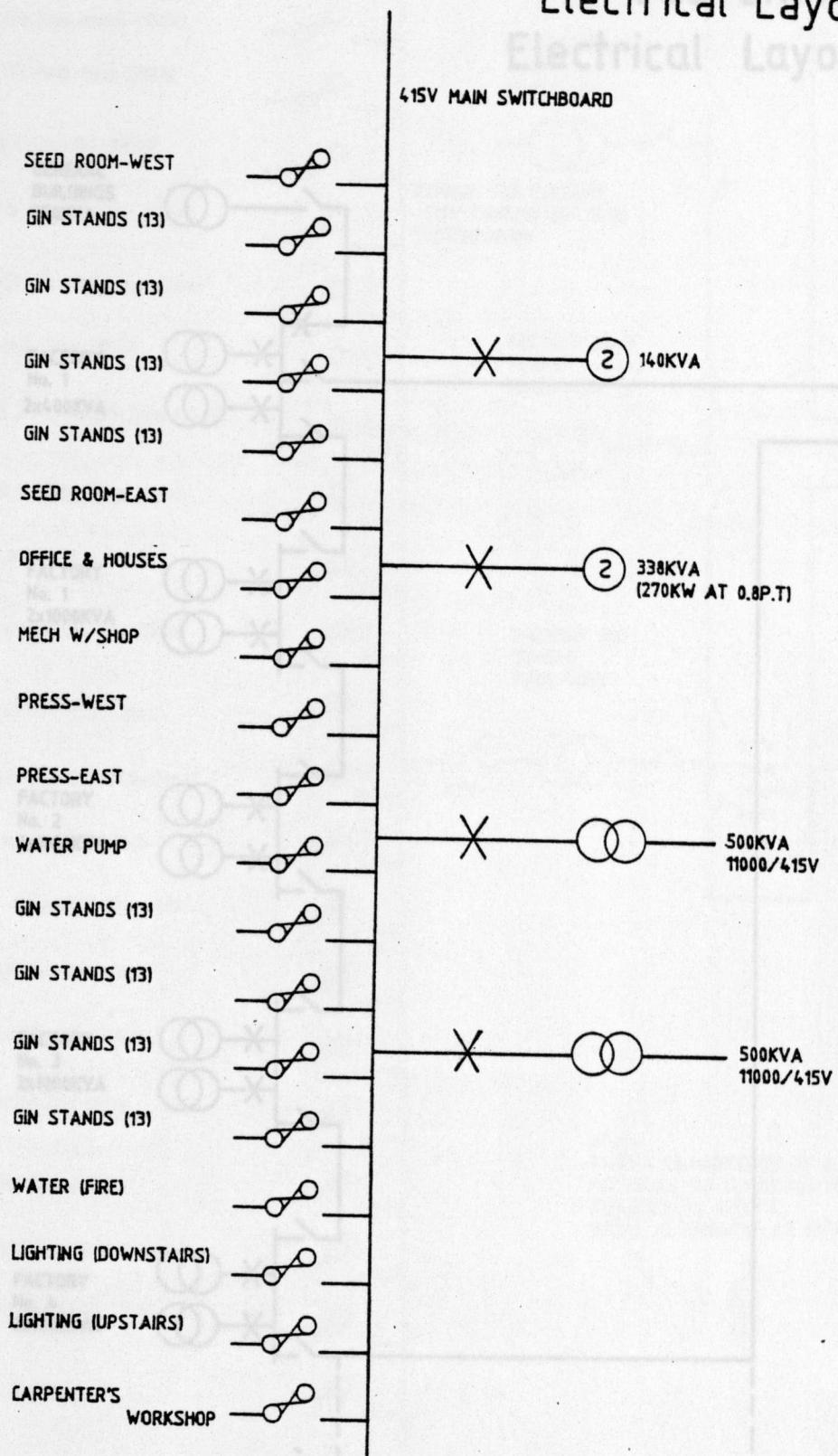


Figure 32

# Fau Ginnery Electrical Layout

GENERAL  
BUILDINGS  
250KVA

FACTORY  
No. 1  
2x400KVA

FACTORY  
No. 1  
2x1000KVA

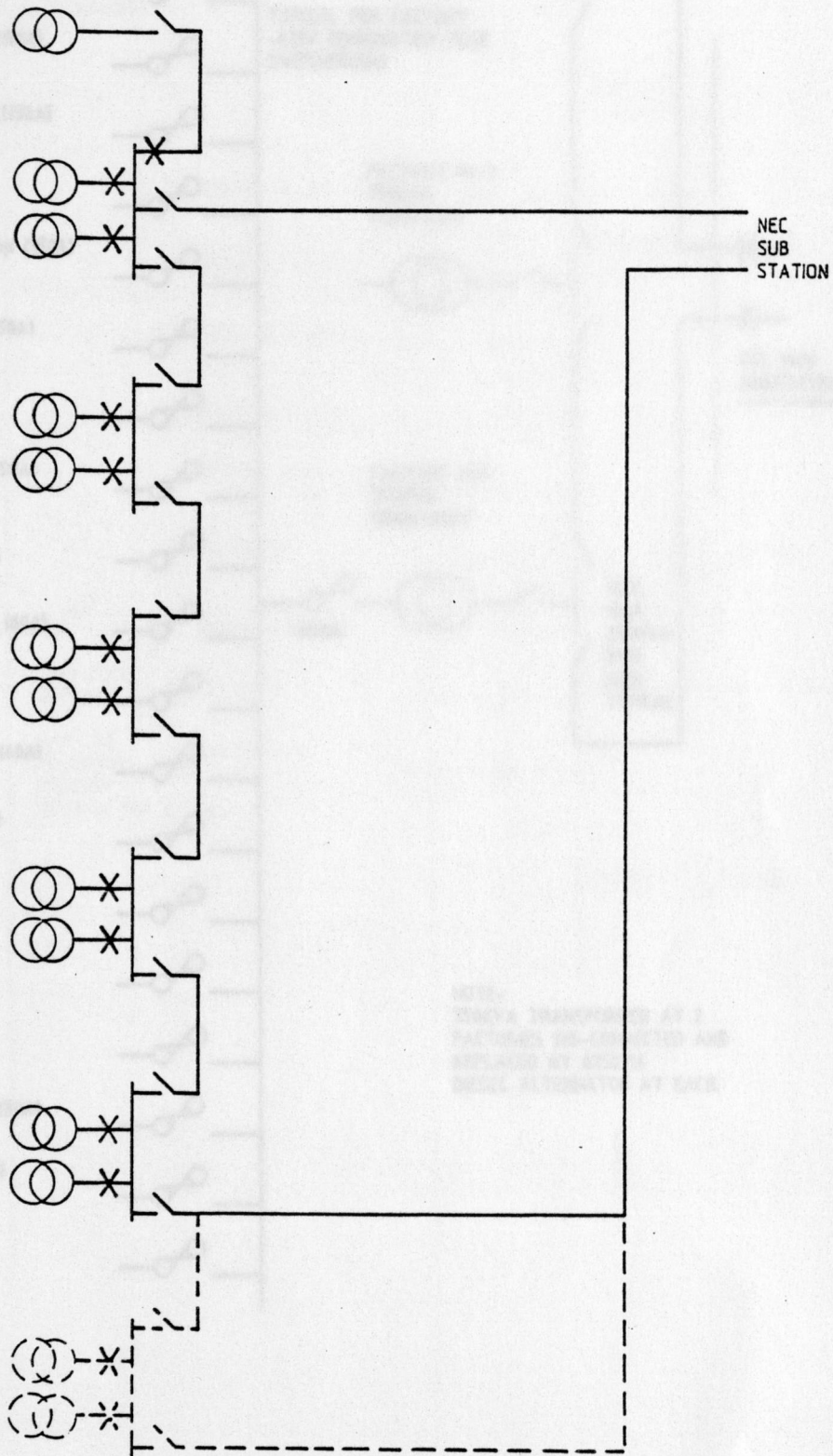
FACTORY  
No. 2  
2x1000KVA

FACTORY  
No. 3  
2x1000KVA

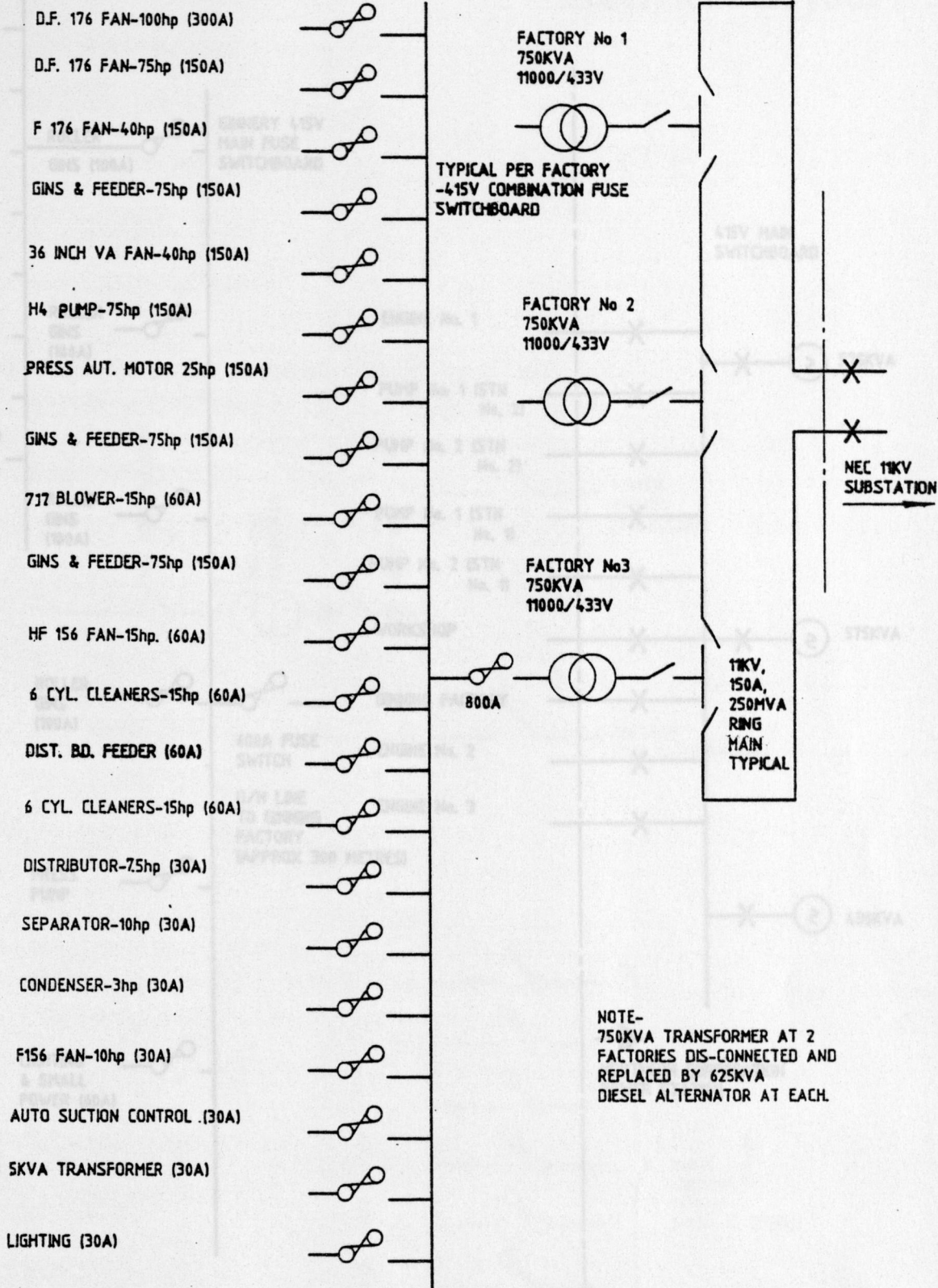
FACTORY  
No. 4  
2x1000KVA

FACTORY  
No. 5  
(FUTURE)  
2x1000KVA

NEC  
SUB  
STATION



# New Halfa Ginnery Electrical Layout



# Zeidab Ginnery Electrical Layout

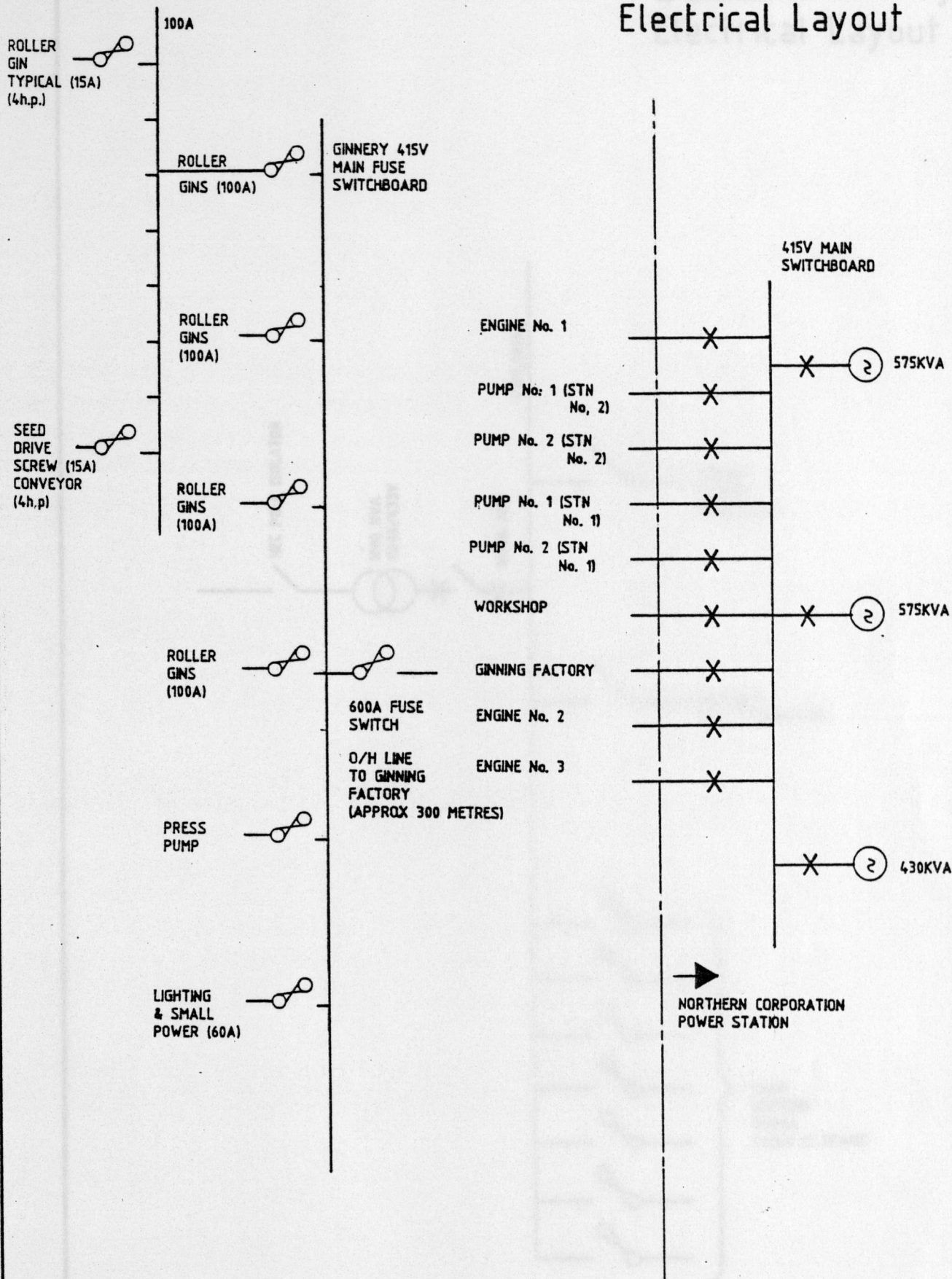


Figure 35

# Damazin Ginnery Electrical Layout

